

## Four-Post Lifts

# Installation and Operation Manual

Manual P/N 5900041 — Manual Revision M — July 2019

Models:

- HD-7P
- HD-7W



**Designed and engineered by BendPak Inc. in Southern California, USA. Made in China.**

 **DANGER**

**Read the *entire contents* of this manual *before* using this product.** Failure to follow the instructions and safety precautions in this manual can result in serious injury or death. Make sure all other operators also read this manual. Keep the manual near the product for future reference. By proceeding with installation and operation, you agree that you fully understand the contents of this manual.

**Manual.** HD-7P and HD-7W Four-Post Lifts, *Installation and Operation Manual*, Manual P/N 5900041, Manual Revision M, Released July 2019.

**Copyright.** Copyright © 2019 by BendPak Inc. All rights reserved. You may make copies of this document if you agree that: you will give full attribution to BendPak Inc., you will not make changes to the content, you do not gain any rights to this content, and you will not use the copies for commercial purposes.

**Trademarks.** BendPak and the BendPak logo are registered trademarks of BendPak Inc. All other company, product, and service names are used for identification only. All trademarks and registered trademarks mentioned in this manual are the property of their respective owners.

**Limitations.** Every effort has been made to make sure complete and accurate instructions are included in this manual. However, product updates, revisions, and/or changes may have occurred since this manual was published. BendPak reserves the right to change any information in this manual without incurring any obligation for equipment previously or subsequently sold. BendPak is not responsible for typographical errors in this manual. You can always find the latest version of the **manual for your product on the BendPak website**.

**Warranty.** The BendPak warranty is more than a commitment to you: it is also a commitment to the value of your new product. Contact your nearest BendPak dealer or visit [www.bendpak.com/support/warranty](http://www.bendpak.com/support/warranty) for full warranty details. Go to [bendpak.com/support/register-your-product/](http://bendpak.com/support/register-your-product/) and fill out the online form to register your product (be sure to click **Submit**).

**Safety.** Your product was designed and manufactured with safety in mind. However, your safety also depends on proper training and thoughtful operation. Do not install, operate, maintain, or repair the unit without reading and understanding this manual and the labels on the unit; **do not use your Lift unless you can do so safely!**

**Owner Responsibility.** In order to maintain your product properly and to ensure everyone's safety, it is the responsibility of the product owner to read and follow these instructions:



- Follow all installation, operation, and maintenance instructions.
- Make sure product installation conforms to all applicable local, state, and federal codes, rules, and regulations, such as state and federal OSHA regulations and electrical codes.
- Read and follow all safety instructions; keep them readily available for operators.
- Make sure all operators are properly trained, know how to safely operate the unit, and are properly supervised.
- Do not operate the product until you are certain that all parts are in place and operating correctly.
- Carefully inspect the product on a regular basis and perform all maintenance as specified.
- Service and maintain the unit with approved replacement parts only.
- Keep instructions permanently with the product and make sure all labels are clean and visible.
- **Only use the Lift if it can be used safely!**

**Unit Information.** Enter the Model Number, Serial Number, and the Date of Manufacture from the label on your unit. This information is required for part or warranty issues.

Model: \_\_\_\_\_

Serial: \_\_\_\_\_

Date of Manufacture: \_\_\_\_\_

<b>BP BendPak</b>		Santa Paula, CA USA www.bendpak.com	
MODEL NUMBER			
DESCRIPTION			
LIFT CAPACITY		DATE OF MFG.	
ROLLING JACK MAX CAP.		MAX PSI / BAR	
VOLTAGE		SERIAL NUMBER	
<input type="checkbox"/> 110-240V, 50-60 Hz, 1 Ph <input type="checkbox"/> 208-240V, 50-60 Hz, 1 Ph <input type="checkbox"/> 380-415V, 50-60 Hz, 3 Ph <input type="checkbox"/> 208-440V, 50-60 Hz, 3 Ph			
		UPC	
 <b>DANGER!</b> Disconnect Power Before Servicing		 <b>WARRANTY VOID IF DATA PLATE IS REMOVED</b> PN 5905952	

---

# Table of Contents

<b>Introduction</b> .....	<b>3</b>	<b>Operation</b> .....	<b>69</b>
<b>Shipping Information</b> .....	<b>4</b>	<b>Maintenance</b> .....	<b>73</b>
<b>Safety Considerations</b> .....	<b>4</b>	<b>Troubleshooting</b> .....	<b>75</b>
<b>Components</b> .....	<b>6</b>	<b>Wiring Diagrams</b> .....	<b>77</b>
<b>Specifications</b> .....	<b>8</b>	<b>Labels</b> .....	<b>79</b>
<b>FAQs</b> .....	<b>10</b>	<b>Parts Drawings</b> .....	<b>82</b>
<b>Installation Checklist</b> .....	<b>11</b>	<b>ALI Store</b> .....	<b>90</b>
<b>Installation</b> .....	<b>12</b>	<b>Maintenance Log</b> .....	<b>91</b>

## Introduction

This manual describes the following BendPak four-post Lifts:

- **HD-7P**: Standard width, can raise Vehicles up to 7,000 pounds (3,175 kg).
- **HD-7W**: Standard *and* wide widths, can raise Vehicles up to 7,000 pounds (3,175 kg).

Both models are ***ALI certified***.

This manual is mandatory reading for all users of the HD-7P and HD-7W, including anyone who installs, uses, maintains, repairs, or wants to know more about them.

 **DANGER** Use care when installing, operating, maintaining, or repairing this equipment; failure to do so could result in property damage, product damage, injury, or (in very rare cases) death. Make sure only authorized personnel operate this equipment. All repairs must be performed by an authorized technician. Do not make modifications to the unit; this voids the warranty and increases the chances of injury or property damage. Make sure to read and follow the instructions in this manual and on the labels on the unit.

Keep this manual on or near the equipment so that anyone who uses or services it can read it.

If you are having issues, refer to the **Troubleshooting** section of this manual for assistance.

Technical support and service is available from your dealer, on the Web at [bendpak.com/support](http://bendpak.com/support), by email at [techsupport@bendpak.com](mailto:techsupport@bendpak.com), or by phone at **(800) 253-2363**, extension 196.

You may also contact BendPak for parts replacement information at **(800) 253-2363**, extension 191; please have the model and serial number of your unit available.

---

# Shipping Information

Your equipment was carefully checked before shipping. Nevertheless, you should thoroughly inspect the shipment **before** you sign to acknowledge that you received it.

When you sign a bill of lading, it tells the carrier that the items on the invoice were received in good condition. **To protect yourself, do not sign until after you have inspected the shipment.** If any of the items listed on the bill of lading are missing or are damaged, do not accept the shipment until the carrier makes a notation on the bill of lading that lists the missing and/or damaged goods.

If you discover missing or damaged goods **after** you receive the shipment and have signed the bill of lading, notify the carrier at once and request the carrier to make an inspection. If the carrier will not make an inspection, prepare a signed statement to the effect that you have notified the carrier (on a specific date) and that the carrier has failed to comply with your request.

It is difficult to collect for loss or damage after you have given the carrier a signed bill of lading. If this happens to you, file a claim with the carrier promptly. Support your claim with copies of the bill of lading, freight bill, invoice, and photographs, if available. Our willingness to assist in helping you process your claim does not make us responsible for collection of claims or replacement of lost or damaged materials.

## Safety Considerations

**Read this entire manual carefully before installing or using the product.** Do not install or operate the product until you are familiar with all operating instructions and warnings. Do not allow anyone else to operate it until they are familiar with all operating instructions and warnings. Keep this manual on or near the product for future reference.

Read and follow the warnings and instructions on the labels on the product. Contact BendPak at **(800) 253-2363** or [techsupport@bendpak.com](mailto:techsupport@bendpak.com) if you need replacement labels or a replacement manual.

### Safety Information

The following safety information applies to the HD-7P and the HD-7W:

- **The product is a four-post Lift.** Use it only for its intended purpose.
- BendPak recommends referring to the current version of the ANSI/ALI ALIS Standard *Safety Requirements for Installation and Service* for information about safely installing and using your Lift.
- The product may only be operated by authorized, trained persons.
- When the Lift is in use, keep all body parts far away from it.
- Do not make any modifications to the Lift; this voids the warranty and increases the chances of injury or property damage.
- Make sure all operators read and understand this *Installation and Operation Manual*. Keep the manual near the Lift at all times.
- Make an inspection of the Lift **before** using it. Check for damaged, worn, or missing parts. Do not use it if you find any of these issues. Instead, take it out of service, then contact an authorized repair facility, your dealer, or BendPak at **(800) 253-2363** or [techsupport@bendpak.com](mailto:techsupport@bendpak.com).
- BendPak recommends making a **thorough** inspection of the product at least once a year. Replace any damaged or severely worn parts, decals, or warning labels.

---

## Symbols

Following are the symbols used in this manual:



**DANGER**

Calls attention to an immediate hazard that **will** result in death or severe injury.



**WARNING**

Calls attention to a hazard or unsafe practice that **could** result in death or severe personal injury.



**CAUTION**

Calls attention to a hazard or unsafe practice that could result in minor personal injury, product damage, or property damage.

**NOTICE**

Calls attention to a situation that, if not avoided, could result in product or property damage.



**Tip**

Calls attention to information that can help you use your product better.

## Liability Information

BendPak Inc. assumes **no** liability for damages resulting from:

- Use of the equipment for purposes other than those described in this manual.
- Modifications to the equipment without prior, written permission from BendPak.
- Damage to the equipment from external influences.
- Incorrect operation of the equipment.

## Electrical Information



**DANGER**

All wiring **must** be performed by a licensed, certified Electrician. Do not perform any maintenance until main electrical power has been disconnected from the Lift and cannot be re-energized until all procedures are complete.

Important electrical information:

- Improper electrical installation can damage the Power Unit motor, which is not covered by the warranty.
- The Lift uses electrical energy; if your organization has Lockout/Tagout policies, make sure to implement them after connecting to a power source.
- Use a separate circuit breaker for each Power Unit.
- Protect each circuit with a time delay fuse or circuit breaker:
  - For a 208 to 230 VAC, **single phase** circuit, use a 25 amp fuse.
  - For a 208 to 230 VAC, **three phase** circuit, use a 20 amp fuse.
  - For a 380 to 440 VAC, **three phase** circuit, use a 15 amp fuse.

---

# Components

The main components of your Lift include:

- **Power Post.** The Post that holds the Power Unit. ***The Power Post can be in either of two locations.*** You can tell the Power Post from the other Posts because it has two Mounting Brackets on it. Mount the Power Unit on one of the two Mounting Brackets.
- **The other three Posts.** These Posts are functionally interchangeable; their Labels are different.
- **Power Unit.** An electric/hydraulic unit that connects to an electric power source and then provides hydraulic power to the Hydraulic Cylinder that raises and lowers the Runways.
- **Lifting Cables.** The two Runways are lifted by .4 inch / 10 mm thick aircraft-quality steel wire rope, *each* of which is rated at 14,400 pounds.
- **Powerside Runway.** The Runway next to the Power Post. The Powerside Runway has Lifting Cables and the Hydraulic Cylinder on its underside. You ***must*** put the Powerside Runway next to the Power Post.
- **Offside Runway.** The other Runway. It does not have an Hydraulic Cylinder or Lifting Cables under it.
- **Utility Rails.** Hold the optional Rolling Jacks. Utility Rails ***must*** go on the inside of the Lift.
- **Crosstubes.** One at each end of the Lift. The Crosstubes are hollow; the Lifting Cables that raise and lower the Runways are routed through the Crosstubes. The Crosstubes are not the same: each Crosstube has an opening (called a Window) that faces the inside (orienting the Windows correctly is described in the Installation section). ***Windows must be installed so that they open to the inside of the Lift.*** Lifting Cables go into the Crosstubes through the Windows.
- **Ramps.** One for each Runway. Use them to drive onto and off of the Runways. By definition, the Ramp end of the Lift is also the Rear of the Lift.
- **Tire Stops.** Located at the Front of the Lift, Tire Stops prevent the Vehicle's front tires from going any further forward. Additionally, we strongly recommend chocking the Vehicle's rear tires.
- **Safety Locks.** Once engaged, they hold the Runways in position, even if the power goes out or there is a leak in the Hydraulic Hoses. Your Lift has 17 Safety Locks, spaced every four inches / 102 mm. This lets you lock the Lift at just the right height for what you want to do. The Lift also has a backup Slack Safety system; refer to **About Safety Locks** for more information. ***Only leave your Lift on the ground or engaged on a Safety Lock.***
- **Pushbutton Air Valve.** Includes a Pushbutton that moves the Safety Locks away from the Ladder so that they do not engage as you lower the Runways. Used only to lower the Runways. Usually located next to the Power Unit.
- **Ladder.** A piece of steel that gets installed at the back of each Post. Each Ladder has 17 holes in it; part of the Safety Lock system.

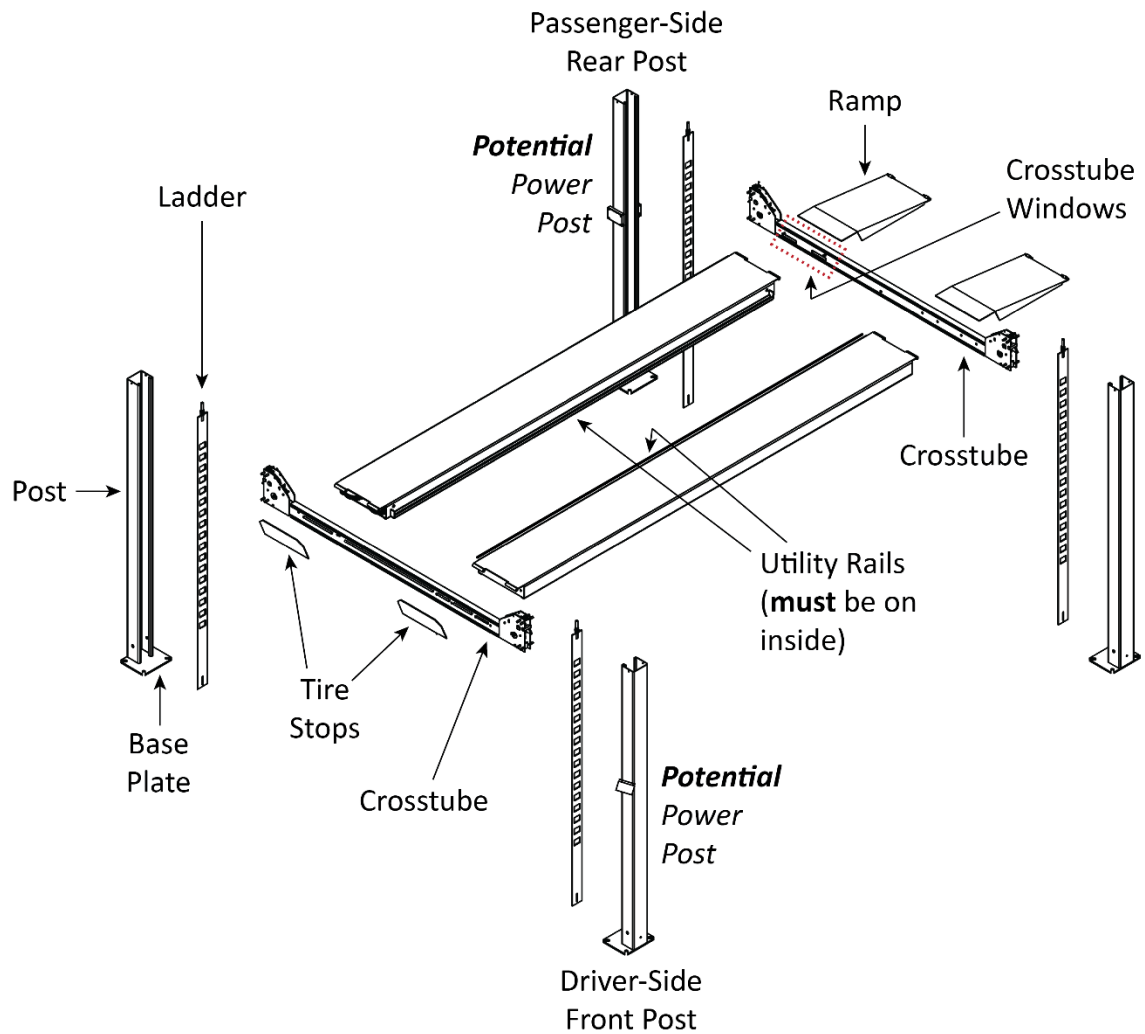

*Drawing not necessarily to scale. Some components not shown. Crosstube Windows for the Crosstube on the left not visible in this view.*

## Accessories

- **Rolling Jack(s).** Optional product that raises wheels of the Vehicle on the Lift off the Runway, making it much easier to perform certain jobs while the Vehicle is still on the Lift. Refer to the [Rolling Jack page on the BendPak website](#) for more information.
- **Air Line Kit.** Optional product that provides the infrastructure to get air to your Rolling Jacks, conveniently routing the air lines under the Lift's Runways. Refer to the [Air Line Kit page on the BendPak website](#) for more information.
- **WSA-100 Utility Station.** Optional product that adds air and electric outlets to your Lift. Refer to the [WSA-100 Utility Station page on the BendPak website](#) for more information.
- **Aluminum Decks.** Optional set of two Aluminum Decks let you store items, including motorcycles and ATVs, on your Lift. Refer to the [Aluminum Deck page on the BendPak website](#) for more information.

# Specifications

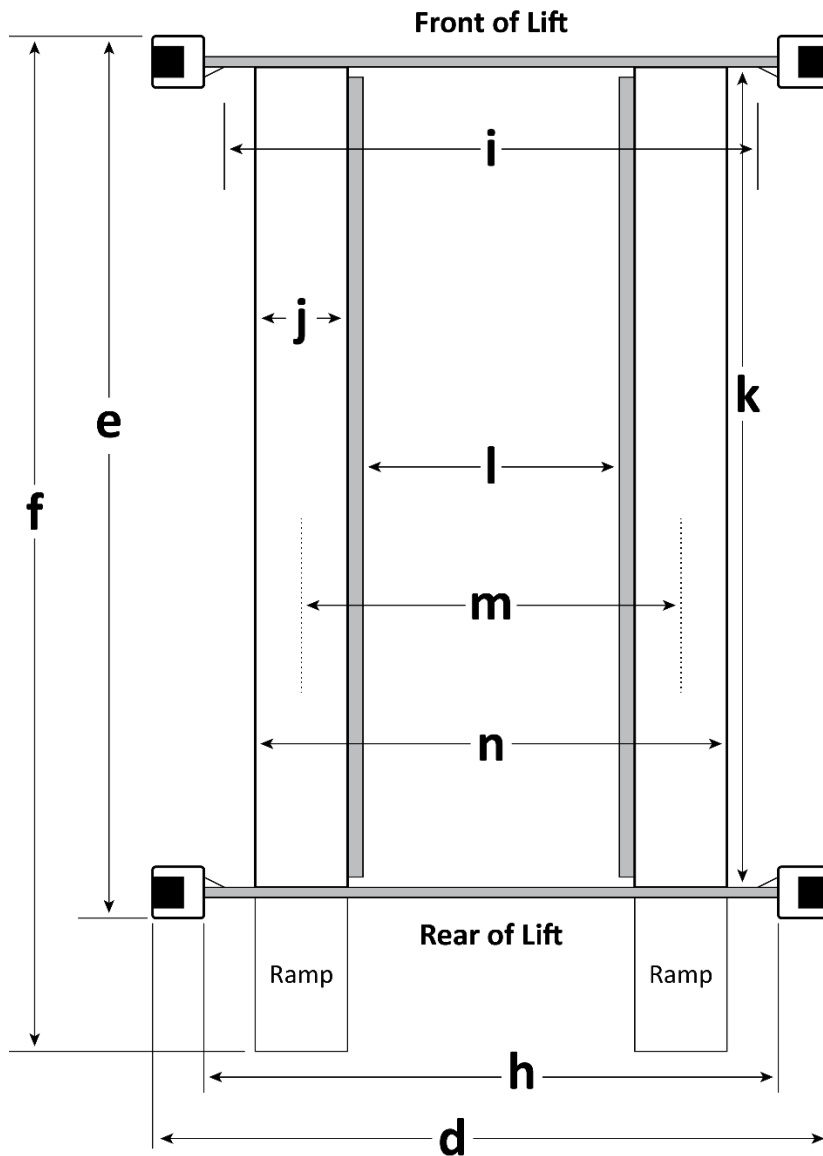
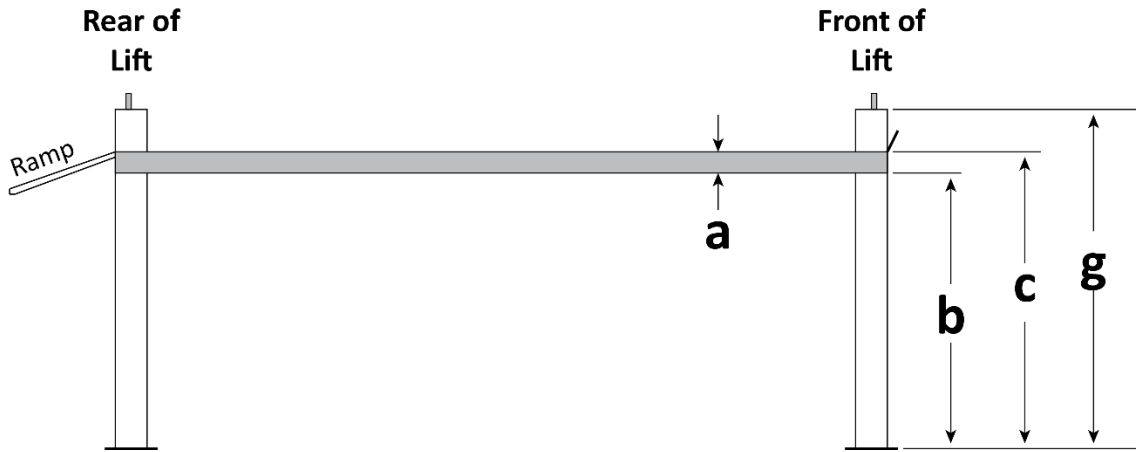



Model	<b>HD-7P</b>	<b>HD-7W</b>
Lifting capacity	7,000 lbs / 3,175 kg	
Maximum capacity front axle	3,500 lbs / 1,750 kg	
Maximum capacity rear axle	3,500 lbs / 1,750 kg	
<b>a</b> Minimum Runway Height	4.5" / 114 mm	
<b>b</b> Maximum Rise	82" / 2,083 mm	
<b>c</b> Maximum Lifting Height	87" / 2,208 mm	
<b>d</b> Overall Width	100.25" / 2,546 mm	110.25" / 2,800 mm
<b>e</b> Outside Length	174" / 4,418 mm	
<b>f</b> Overall Length	200" / 5,078 mm	
<b>g</b> Height of Posts	100" / 2,537 mm	
<b>h</b> Distance Between Posts	90.25" / 2,292 mm	100.25" / 2,546 mm
<b>i</b> Drive-Through Clearance	76.5" / 1,943 mm	86.5" / 2,197 mm
<b>j</b> Runway Width	19" / 482 mm	
<b>k</b> Runway length	164.5" / 4,178 mm	
<b>l</b> Width Between Runways	38" / 963 mm	38" / 963 mm or 44.25" / 1,121 mm
<b>m</b> Runway Centerline	56.5" / 1,437 mm	56.5" / 1,437 mm or 63.5" / 1,610 mm
<b>n</b> Outside Edge of Runways	75.5" / 1,919 mm	75.5" / 1,919 mm or 82.5" / 2,092 mm
Min. Wheelbase @ rated capacity <sup>1</sup>	115" / 2,921 mm	
Min. Wheelbase @ 75% capacity <sup>1</sup>	100" / 2,540 mm	
Min. Wheelbase @ 50% capacity <sup>1</sup>	85" / 2,159 mm	
Min. Wheelbase @ 25% capacity <sup>1</sup>	70" / 1,778 mm	
Locking Positions	17, spaced every 4" / 102 mm	
Lifting time	~35 seconds	
Motor	208-230 VAC, 60 Hz, 1 Ph	
Max normal operating pressure	208-230 VAC: 2,600 PSI	
Power Unit PRV setting	208-230 VAC: 2,900 PSI	
Sound (when raising/lowering)	<70 dBA	
Air supply	3 to 25 cfm at 50 to 150 psi	

<sup>1</sup> The Lift supports less weight than its rated capacity when the Vehicle's wheelbase is shorter; this is because the wheels are closer to the middle of the Runways, where there is less strength.

**Specifications subject to change without notice.**

---

# Frequently Asked Questions

**Question:** What kinds of Vehicles can I put on my Lift?

**Answer:** Cars, trucks, SUVs; anything that fits on the Runways, up to 7,000 lbs (3,175 kg).

**Q:** How long does it take to raise or lower my Lift with a Vehicle on it?

**A:** About 35 seconds. Longer if there is no weight on it.

**Q:** Does the Lift have a Front and a Rear?

**A:** Yes. For a four-post Lift, the end **opposite** the Ramps is the Front; the end with the Ramps is the Rear.

**Q:** Do I have to put my Power Unit in a particular location?

**A:** Yes. Your Power Post (the Post the holds the Power Unit) must be located at either the Driver-Side Front or the Passenger-Side Rear of the Lift.

**Q:** Does the Lift have to be anchored in place?

**A:** It is up to you. Anchoring your Lift makes it more stable, but prevents you from moving it around using the optional Caster Kit. Anchoring a four-post Lift is **not** required.

**Q:** How high does the ceiling have to be?

**A:** It depends on the height of the Vehicle you are raising and how high you raise the Runways. The general rule is: 87 inches plus the height of the Vehicle should prevent any problems. However, before raising a Vehicle, **BendPak strongly recommends measuring**.

**Q:** Does it matter if I drive my Vehicles in front first or back them in?

**A:** We recommend driving your Vehicle in front first, because that makes it easier to center the wheels on the Runways. But it is up to you; the Lift works great either way. Also, remember to put the Front wheels up against the Tire Stops and chock the Rear wheels.

**Q:** Will the Lifting Cables really hold my Vehicle?

**A:** Yes. Each Lifting Cable is .4 inch thick, aircraft-quality steel **wire rope**. Each Lifting Cable is rated to hold 14, 400 pounds.

**Q:** Do I need an Air Supply?

**A:** Yes. An Air Supply (3 to 25 cfm at 50 to 150 psi) is required to disengage the Safety Locks when you want to lower the Lift. Regulate the line to a maximum pressure of 150 psi; the air lines could burst or the Safety Locks malfunction at pressure over 150 psi.

**Q:** How long can I leave a Vehicle on a raised Runway?

**A:** As long as you want. Once the Lift is engaged on a Safety Lock, gravity holds it in position, so a loss of power or a leaking Hydraulic Hose does not impact it; it is going to stay where you left it. **Only leave your Lift either fully lowered or engaged on Safety Locks.**

**Q:** Can I install my Lift outside?

**A:** No. Your Lift is approved for indoor installation and use only. **Outdoor installation is prohibited.**

**Q:** How many Safety Lock positions does my Lift have?

**A:** 17, spaced every 4 inches / 102 mm.

---

# Installation Checklist

Following are the steps needed to install your Lift. Perform them in the order shown.

- 1. Review the Safety Rules.
- 2. Make sure you have the necessary Tools.
- 3. Plan for electrical work.
- 4. Select an Approach.
- 5. Choose a Power Post Location.
- 6. Check the Clearances.
- 7. Select the Installation Location.
- 8. Unload and unpack the Lift Components.
- 9. Create Chalk Line Guides.
- 10. Move the Posts into position.
- 11. Install the Crosstubes.
- 12. About Safety Locks.
- 13. Install the Ladders and Top Caps.
- 14. Raise the Crosstubes.
- 15. Secure the Ladders.
- 16. Remove the Sheaves.
- 17. Install the Runways.
- 18. Install the first end of the Flex Tube.
- 19. Route the Lifting Cables.
- 20. Working with Compression Fittings and Tubing.
- 21. Install the Air Lines.
- 22. Install the Hydraulic Hose.
- 23. Install the Return Line.
- 24. Install the Power Unit.
- 25. Install the second end of the Flex Tube.
- 26. Install the Pushbutton Air Valve and connect the Air Line.
- 27. Connect the Return Line.
- 28. Connect the Hydraulic Hose.
- 29. Contact the Electrician.
- 30. Connect to a power source (***Electrician required***).
- 31. Install the Power Disconnect Switch and Thermal Disconnect Switch (***Electrician required***).
- 32. About Effective Embedment.
- 33. Anchor the Posts.
- 34. Perform final leveling.
- 35. Install the Accessories.
- 36. Lubricate the Lift.
- 37. Perform an Operational Test.
- 38. Review the Final Checklist.

---

# Installation

The installation process takes multiple steps. Perform them in the order listed.

**Read the entire Installation section before beginning the install**, this gives you a better understanding of the process as a whole.

 **WARNING** **Only use the factory-supplied parts that came with your Lift.** If you use parts from a different source, you void your warranty and compromise the safety of everyone who installs or uses the Lift. If you are missing parts, visit [bendpak.com/support](http://bendpak.com/support) or call **(800) 253-2363**, extension 191.

## Being Safe

While installing this equipment, your safety depends on proper training and thoughtful operation.

 **WARNING** Do not install this equipment unless you have automotive Lift installation training. Always use proper lifting tools, such as a Forklift or Shop Crane, to move heavy components. Do not install this equipment without reading and understanding this manual and the safety labels on the unit.

Only fully trained personnel should be involved in installing this equipment. Pay attention at all times. Use appropriate tools and lifting equipment. Stay clear of moving parts.

BendPak recommends referring to the current version of the ANSI/ALI ALIS Standard *Safety Requirements for Installation and Service* for more information about safely installing, using, and servicing your Lift.

 **WARNING** You must wear appropriate protective equipment **at all times** during installation: gloves, steel-toe work boots, eye protection, back belts, and hearing protection.

## Tools

You may need some or all of the following tools:

- Rotary hammer drill (or similar)
- 3/4 inch carbide bit (conforming to ANSI B212.15)
- Hammer, crow bar, and two sawhorses
- Four-foot level and 12-foot ladder
- Open-end wrench set, SAE and metric
- Socket and ratchet set, SAE and metric
- Hex key wrench set
- Medium crescent wrench, torque wrench, pipe wrench
- Chalk line
- Medium-sized flat screwdriver and needle-nose pliers
- Tape measure (25 feet or above)
- Forklift, shop crane, or heavy-duty rolling dolly

---

## Planning for Electrical Work

You will need to have a licensed, certified Electrician available at some point during the installation.

**⚠ DANGER** All electrical work **must** be performed by a licensed, certified Electrician.

Notify your Electrician in advance so that they come prepared with appropriate components for connecting to the power source, a Power Disconnect Switch, and a Thermal Disconnect Switch. Refer to **Contacting the Electrician** for more information.

Your Electrician needs to:

- **Connect the Power Unit to an electric power source.** An electric power source is required. The Power Unit comes with a Pigtail for wiring to a power source. Have your Electrician connect a power cord with appropriate plug to the electrical box on the Lift (for connection to a power outlet) or have them wire it directly into the electrical system at the Lift location.

Note that *installing* the Power Unit and *connecting* the Power Unit to the power source are separate procedures and are done at different times in the installation process. You do **not** need an Electrician to *install* the Power Unit, but an Electrician is **required** to connect the Power Unit to the power source.

- **Install a Power Disconnect Switch.** Ensures you can quickly and completely interrupt electrical power to the Lift in the event of an electrical circuit fault, emergency situation, or when equipment is undergoing service or maintenance. Put it within sight and reach of the Lift operator.
- **Install a Thermal Disconnect Switch.** Ensures the equipment shuts down in the event of an overload or an overheated motor.

**Note:** These components are not supplied with the Lift.

## Selecting an Approach Direction

You need to pick an Approach, the direction you will drive Vehicles onto your Lift, near the beginning of the installation process. It determines where your Ramps and Tire Stops go on the Lift and the Front and Rear of the Lift.

Selecting an Approach does not impact your Power Post location choice.

In many cases, selecting an Approach is easy: the garage/shop has walls on three sides and an open door on the fourth side. The open door is the Approach side. If your location has an open door on both ends, pick one side to be the Approach side; install your Ramps on the Approach side and the Tire Stops on the other side.

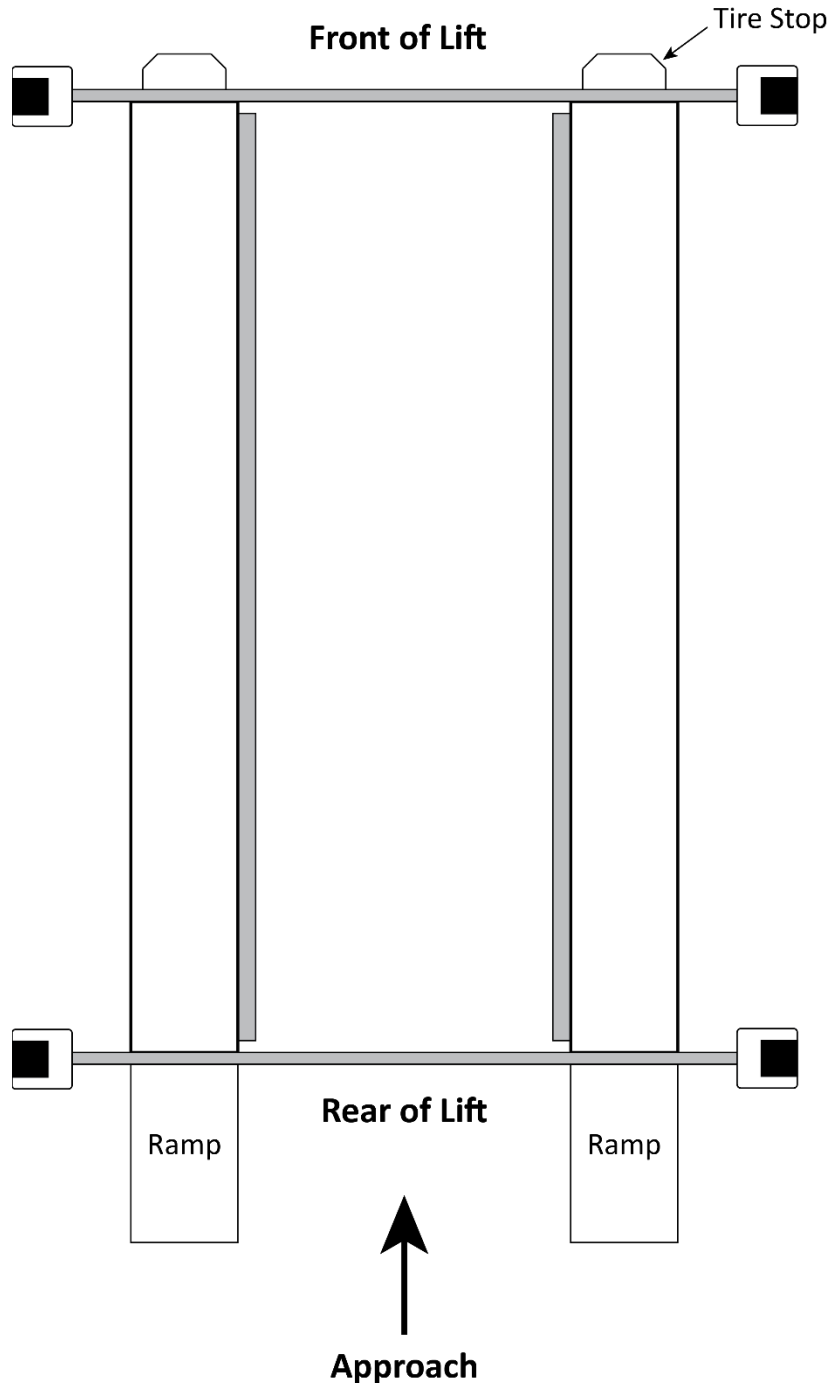

## Selecting a Power Post Location

You need to pick a Power Post location now, near the beginning of the installation process, as its location impacts other aspects of the installation.

**Note:** The Power Post location decision has no impact on the Approach direction or where the Front and Rear of the Lift are. It does impact other aspects of the installation, however.

You have two options for Power Post location: Driver-Side Front or Passenger-Side Rear.

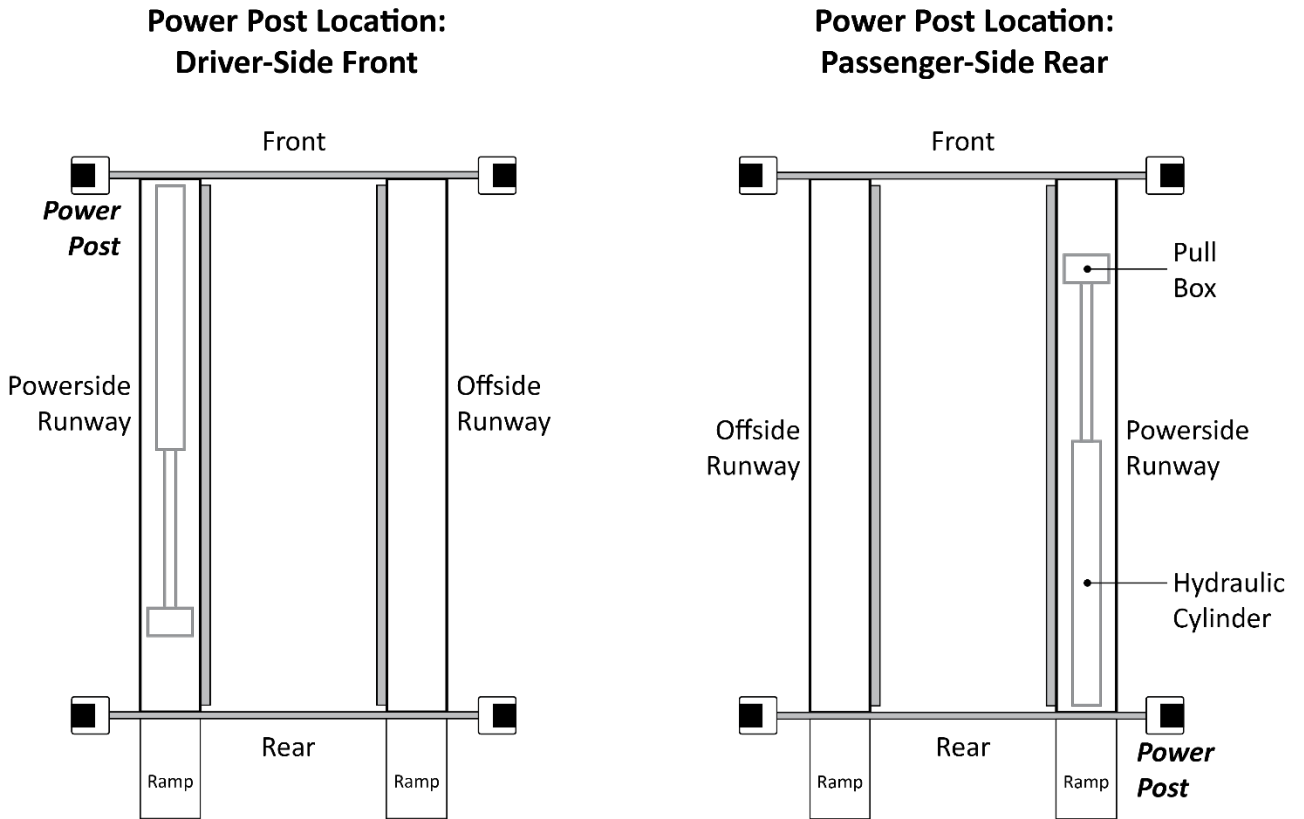

*Drawing not necessarily to scale. Not all components shown. Powerside Runway (which has the Hydraulic Cylinder under it) **must** be installed next to the Power Post, no matter which Power Post location you choose.*

Most customers choose their Power Post location based on either preference (one option makes more sense for their shop than the other does) or easier access to the power source.

## Checking Clearances

For safety purposes, a certain amount of clear space around the Lift is **required**.

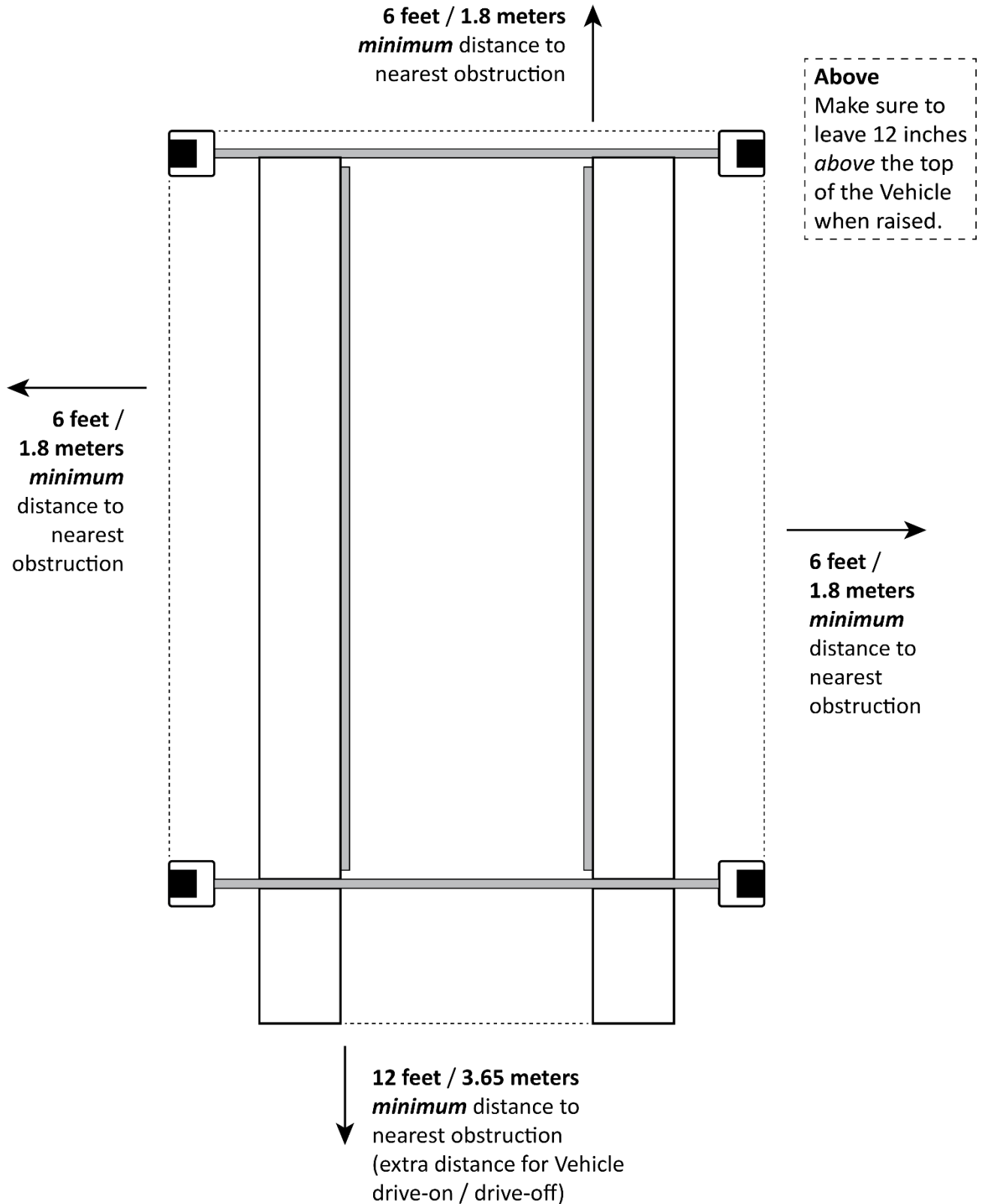

*Drawing is a top view. Not necessarily to scale. Not all components shown.*



---

## Selecting a Location

When selecting the location for your Lift, consider:

- **Architectural plans.** Consult the architectural plans for your desired installation location. Make sure there are no issues between what you want to do and what the plans show.
- **Available space.** Make sure there is enough space for the Lift: front, back, sides, and **above**. Refer to **Specifications** for measurements.
- **Overhead obstructions.** Check for overhead obstructions such as building supports, heaters, electrical lines, low ceilings, hanging lights, and so on. **You do not want the Vehicles on the Lift hitting obstructions.** The Lift location should have 87 inches of height plus the height of the tallest Vehicle you plan on raising, if you want to make sure you do not hit anything overhead.
- **Side and front clearances.** You must leave room around the Lift. Leave at least six feet (72 inches / 1.8 meters) clear on both sides and the front of the Lift, and no obstructions at all at the Rear of the Lift (so you can safely drive Vehicles onto the Runways).
- **Power.** You need an appropriate power source for the Power Unit.
- **Outdoor installations.** Your Lift is approved for **indoor** installation and use **only**.
- **Floor.** Only install the Lift on a flat, Concrete floor; do not install on asphalt or any other surface. The surface must be level; do not install if the surface has more than three degrees of slope.

 **WARNING** Installing your Lift on a surface with more than three degrees of slope could lead to injury or even death. Only install the Lift on a level floor. If your floor is not level, consider making the floor level or using a different location.

- **Shimming.** If your Concrete floor is not completely level, you can use Shims under the bases of the Posts, as needed, to level the Lift.

To estimate your Shim requirements, use a transit level and targets to check for flatness. Use the provided Shims as necessary.

**NOTICE** Do not shim a Post more than half an inch using the provided Shims and Anchor Bolts. A maximum shim of 2 inches is possible by ordering optional Shim Plates. Contact BendPak at **(800) 253-2363**, extension 191 to order.

- **Concrete specifications.** Do not install the Lift on cracked or defective Concrete. Make sure the Concrete is at least 4.25 inches thick, 3,000 PSI, and cured for a minimum of 28 days. Do not install Anchor Bolts within six inches of cracks or other defects in the Concrete.

 **CAUTION** BendPak lifts are supplied with installation instructions and Concrete anchors that meet the criteria set by the current version of the American National Standard “Automotive Lifts – Safety Requirements for Construction, Testing, and Validation”, ANSI/ALI ALCTV. You are responsible for any special regional structural and/or seismic anchoring requirements specified by any other agencies and/or codes such as the Uniform Building Code (UBC) and/or International Building Code (IBC).

Be sure to check your Concrete floor for the possibility of it being a **post-tension slab**. In this case, you must contact the building architect before drilling. Using ground penetrating radar may help you find the tensioned steel.

 **WARNING** Cutting through a tensioned cable can result in injury or death. Do not drill into a post-tension slab unless the building architect confirms you are not going to hit tensioned steel or you have located it using ground penetrating radar. **If colored sheath comes up during drilling, stop drilling immediately.**

---

## Unloading and Unpacking

Try to have the components of the Lift unloaded near the installation location.

Once the components are unloaded, they are your responsibility to move around. As the Lift includes a number of heavy pieces, the closer you unload them to the installation location, the better off you are.

 **CAUTION** Some Lift components are very heavy; if handled incorrectly, they can damage materials like tile, sandstone, and brick. Try to handle the Lift components twice: once when delivered and once when moved into position. You must have a Forklift or Shop Crane to move them into position. Use care when moving them.

 **WARNING** The Posts and Runways are delivered with stabilizing structures on each end. Be very careful when removing these stabilizing structures; the Posts and Runways can shift or even fall. If they fall on a person, they could cause serious injury.

## Creating Chalk Line Guides

Create Chalk Line Guides so that the outside edges of all four Post bases fit into the four corners created by the Chalk Line Guides.

Refer to **Specifications** to determine the **Overall Width** and **Outside Length** values for your Lift.

**Note:** Do *not* use the **Overall Length** value; this includes the Ramps, which are not taken into consideration for creating Chalk Line Guides.

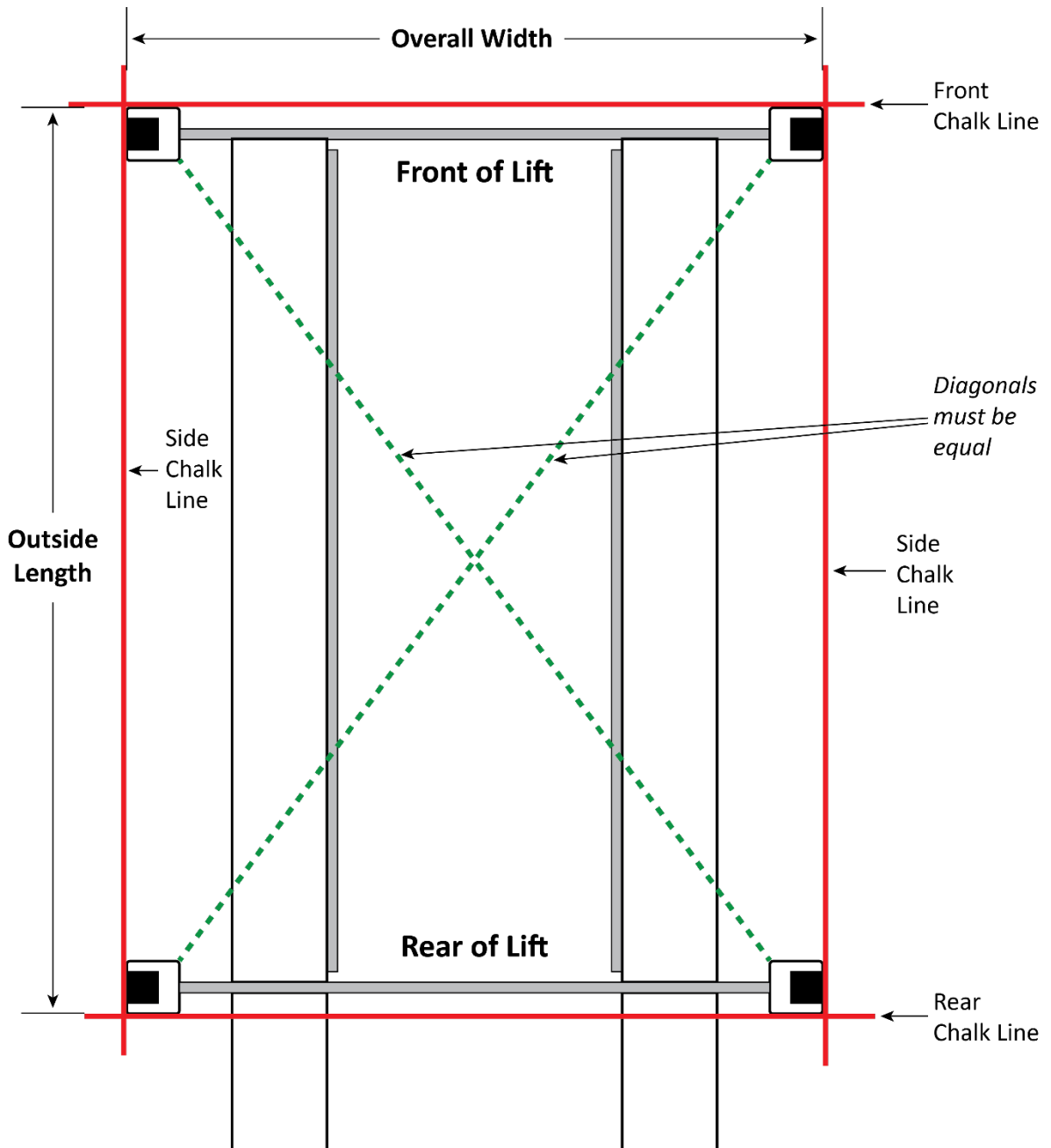

*Drawing is a top view. Not necessarily to scale. Not all components shown.*

---

### To create Chalk Line Guides:

1. Create the Front Chalk Line where you want the Front of the Lift.

The Front of the Lift is the end opposite the Ramps.

Make the Front Chalk Line longer, by 12 inches on each end, than the **Overall Width** setting.

2. Create the two side Chalk Lines at 90° angles to the Front Chalk Line and parallel to each other. Make the side Chalk Lines longer (by 12 inches on each end) than the **Outside Length** setting.

The side Chalk Lines **must** be parallel to each other.

*Measure to verify that they are parallel.*

3. Create the Rear Chalk Line parallel to the Front Chalk Line. Make the Rear Chalk Line longer than the **Overall Width** setting for your Lift model.

The Front and Rear Chalk Lines **must** also be parallel to each other.

*Measure to verify that they are parallel.*

4. Before moving the Posts into position, measure **diagonally** to make sure the two diagonal measurements are the same. This ensures your layout is correct.

***Do not forget to check the diagonals.***

5. When you move the Posts into position, put the outside edges of the bases inside the corners created by the Chalk Line Guides.

---

## Moving the Posts into Position

Use a Forklift or Shop Crane to move the Posts. You need to have **at least two people** work together to stand up the Posts.

 **DANGER** The Posts are heavy and awkward; be very careful when handling them. If they fall on a person, they will cause injury.

### To move the Posts into position:

1. Using a Forklift or Shop Crane, move the four Posts, one at a time, to the inside corners of the Chalk Line Guides.

**Important:** Position the Power Post at the location you chose earlier. The other three Posts can go at any of the remaining Post locations.

2. Stand up each Post.

Have **at least two people** work together to stand up a Post.

 **WARNING** Be very careful when walking around the Posts; they are not anchored down at this point, so it is possible to knock them over, which could cause significant injury.

3. Orient each Post as you stand it up.

The inside (where the Lift Head is) of each Post needs to face the inside of the Post across from it on the other side of the Lift.

### **4. Do not anchor the Posts at this point.**

You may or may not be anchoring the Posts at all, depending on whether or not you are going to be using the optional Caster Kit. But even if you are planning on anchoring the Posts *eventually*, **do not anchor the Posts now.**

## Installing the Crosstubes

Your Lift has two Crosstubes; **they are similar, but not the same**:

- **One with Two Large Windows:** This Crosstube has two **Large** Windows. Must be installed at the Pull Box end of the Powerside Runway.
- **One with Two Small Windows:** This Crosstube has two **Small** Windows. Must be installed adjacent to the Power Post.

Both Crosstubes are hollow, which allows the Lifting Cables to be run through them to the Posts.



### Tip

It is possible to install the Crosstubes **incorrectly** in several different ways. Take your time and get it right the first time.

Both Crosstubes **must** be installed so that the Windows open to the **inside** of the Lift.

**Important:** Your Power Post location impacts Crosstube installation. The Crosstube with two Small Windows **must** be installed next to the Power Post. The location of the Ramps do not come into play when determining where the Crosstubes get installed.

Crosstubes **must** be installed so that their Windows are on the Powerside Runway side of the Lift.

The following drawing shows the two Crosstube setups based on Power Post location.

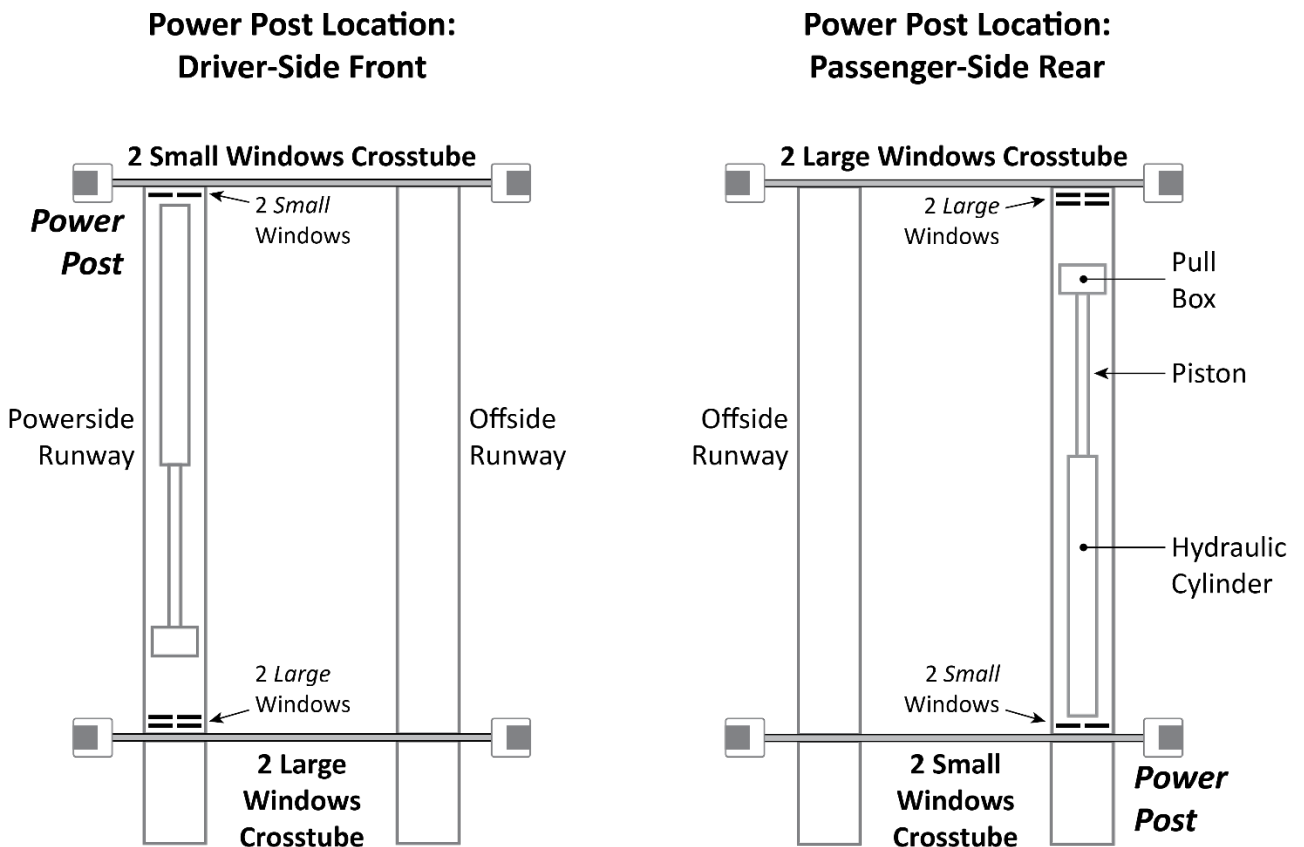

Top view. Drawing not to scale. Some components not shown. The location of the Ramps does not change based on Power Post location, but the Powerside Runway and Crosstube locations do. Windows are in the Crosstubes; they are shown here at the ends of the Powerside Runway for clarity.

## To install the Crosstubes:

1. Orient the Crosstubes in their **required** locations:
  - The Crosstube with two Large Windows must be on the Pull Box end of the Powerside Runway with both Windows facing the inside of the Lift.
  - The Crosstube with two Small Windows must be located next to the Power Post with both Windows facing the inside of the Lift.

Both Windows *must* be on the ends of the Powerside Runway and facing the inside of the Lift.

2. Lean over the **two** Posts at one end of the Lift (some people put them on Sawhorses, some people let them lay on the ground), slide the Crosstube into place, then stand the Posts back up again (make sure to put them back into their correct locations).

or

Using a Forklift or Shop Crane, raise a Crosstube above the top of the two Posts that it goes between, then slide the Crosstube down into place.

3. Perform Step 2 for the second Crosstube.

## About Slide Blocks

The black Slide Blocks in the corners of the ends of the Crosstubes come installed from the factory. If they fall off or do not come installed, put them into place so that each pair creates a Slot into which the Ladder for each Post will be installed later in the installation procedure.

The following drawing is a top view of how two Slide Blocks get put into position on the end of a Crosstube.

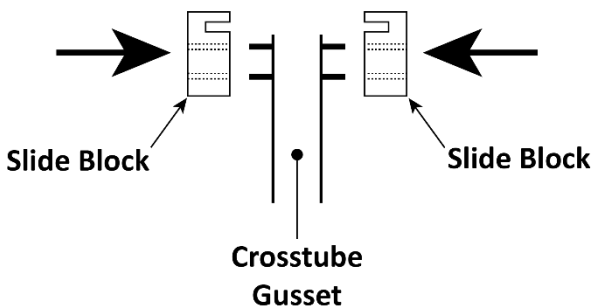

The following drawing is a top view that shows the Slot created by the two Slide Blocks when they are installed. There are two Slots per Crosstube Gusset, one at the top and one at the bottom. *The Ladder must go through both Slots.*

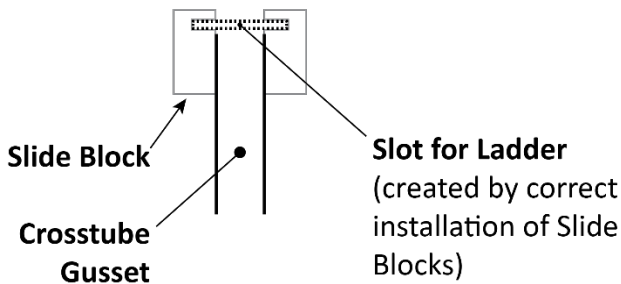

**Important:** It is easy to see the top Slot created by the Slide Blocks. It is difficult to see the bottom Slot, but it is **required** that the Ladder go through **both** Slots.

---

## About Safety Locks

Your Lift has two Safety Lock systems:

- **Primary Safety Locks.** Located at the ends of each of the four Crosstubes, the Primary Safety Locks hold the Runways in place *once they are engaged*. Primary Safety Locks are used over 99 percent of the time. Once engaged, Primary Safety Locks hold the Runways in place, even if the power goes out or the Hydraulic Hoses break or leak.
- **Slack Safety Locks.** Also located at the ends of each of the four Crosstubes, the Slack Safety Locks are a backup system in case any of the four Lifting Cables ever breaks (which is a rare occurrence). During normal operation, the Lifting Cables prevent the Slack Safety Locks from engaging, but if a Lifting Cable breaks while the Lift is not engaged on its Primary Safety Locks, the Slack Safety Lock next to the broken Lifting Cable immediately engages at the next Safety Lock position in the Ladder.

The Slack Safety Locks get engaged during installation when you raise the Crosstubes (see [Raising the Crosstubes](#)). Make sure to disengage them immediately after raising the Crosstubes.

**Important:** Simply raising the Runways does not **engage** them on the Primary Safety Locks. You must back the Runways down onto the Safety Locks to engage them.

Each of the Lift's four Posts has its own Ladder. Each Ladder has 17 Safety Lock holes. The Primary Safety Locks and the Slack Safety Locks share the Safety Lock holes.

**⚠ WARNING** Safety Locks are dependent on correct installation of the Ladders. Pay careful attention when installing the Ladders. If they not installed correctly, the Lift may not be able to hold the weight of a Vehicle, which could fall and damage the Vehicle or the Lift, or cause harm to any persons in the area.

The Ladders are steel pieces with holes spaced every four inches. As you raise the Runways, the Primary Safety Locks move into the holes in the Ladder (they make a distinct sound when they do) as they pass by the Safety Lock holes.

When you move the Runways back down after passing a Safety Lock hole, the Primary Safety Lock engages. You will know this when the Runways stop moving down. Once they are engaged, Primary Safety Locks stay engaged until you lower the Runways. Even if the power goes out or one of the Hydraulic Hoses breaks or leaks, the *engaged* Primary Safety Locks hold the Runways in place.

**⚠ WARNING** Always leave the Lift's Runways either fully lowered or engaged on Primary Safety Locks. When you engage the Primary Safety Locks at a desired height, check to make sure that all four (one per Post) are engaged at the same height.

So how do the Runways come down if the Primary Safety Locks are engaged? To lower the Runways, you raise them a few inches (to get them off the Primary Safety Locks), then **press and hold down** the pushbutton on the Pushbutton Air Valve. While you hold down the pushbutton, the Primary Safety Locks are moved away from the Safety Lock holes in the Ladders; they are prevented from engaging, which allows the Runways to be lowered.



## Installing the Ladders and Top Cap

Your Lift has four Ladders (one per Post); each Ladder gets installed on the inside back of a Post. Ladders are secured at the top and the bottom. All four Ladders are identical.

It is **not** necessary to slide the Ladders in from the very top of the Post.

The Top Caps secure the Ladder at the top of each Post and hold the ends of the Lifting Cables.

**Note:** It is much easier to secure the bottom of the Ladders once the Crosstubes have been raised, so that portion of installing the Ladders is described in [Securing the Ladders](#).

Each Ladder has 17 holes in it, spaced four inches apart; these holes are for the Safety Locks. Each Ladder has a Bolt Hole at the bottom and a Threaded Bolt at the top.

**⚠ WARNING** Make sure to install the Ladders correctly. If they are not installed correctly, the Safety Locks on your Lift may not hold the weight of a Vehicle, putting anyone under and around the Lift in danger.

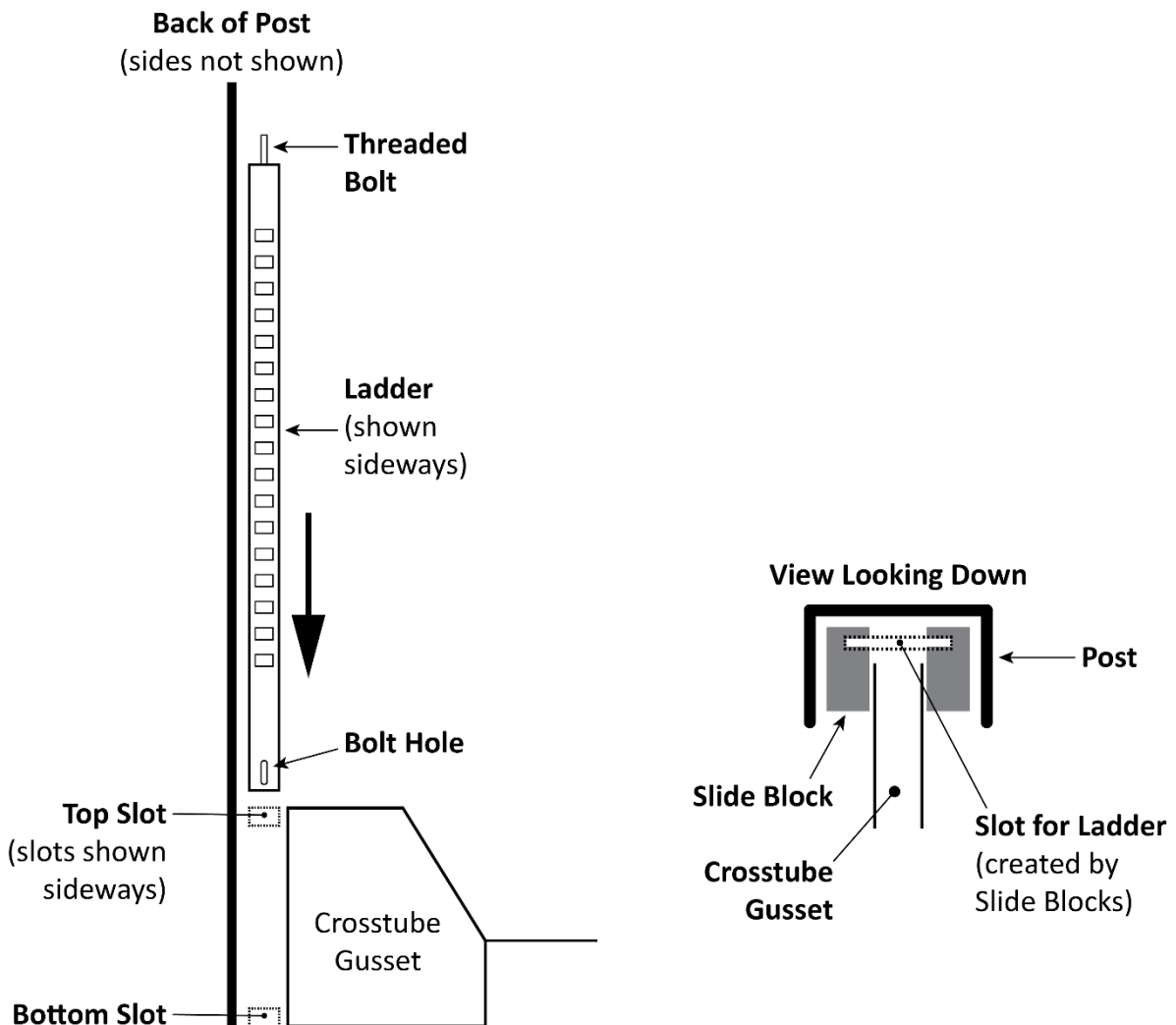

*Not necessarily to scale. Not all components shown. Front and side views combined. Make sure to install each Ladder through **both Slots** on each Crosstube Gusset.*

## To install the Ladders and the Top Cap:

1. Take a Ladder and slide it down the back of a Post, with the Bolt Hole end at the bottom.

Make sure the Ladder goes through **both** Slots on each Gusset. There is a Slot at the top of the Gusset and another Slot at the bottom of the Gusset; both are formed by the Slide Blocks.

**Important:** It is easy to see the top Slot created by the Slide Blocks. It is difficult to see the bottom Slot, but it is **required** that the Ladder go through **both** Slots.

If the Ladder misses a Slot or the Slide Blocks were not installed correctly, your Safety Locks will **not** function correctly.

**⚠ WARNING** Make sure all four Ladders go through **both** Slots created by the Slide Blocks.

2. Install the other three Ladders the same way.
3. **Moving to the top of the Ladders**, move the Stop Nut half of the way down towards the top of the Ladder.

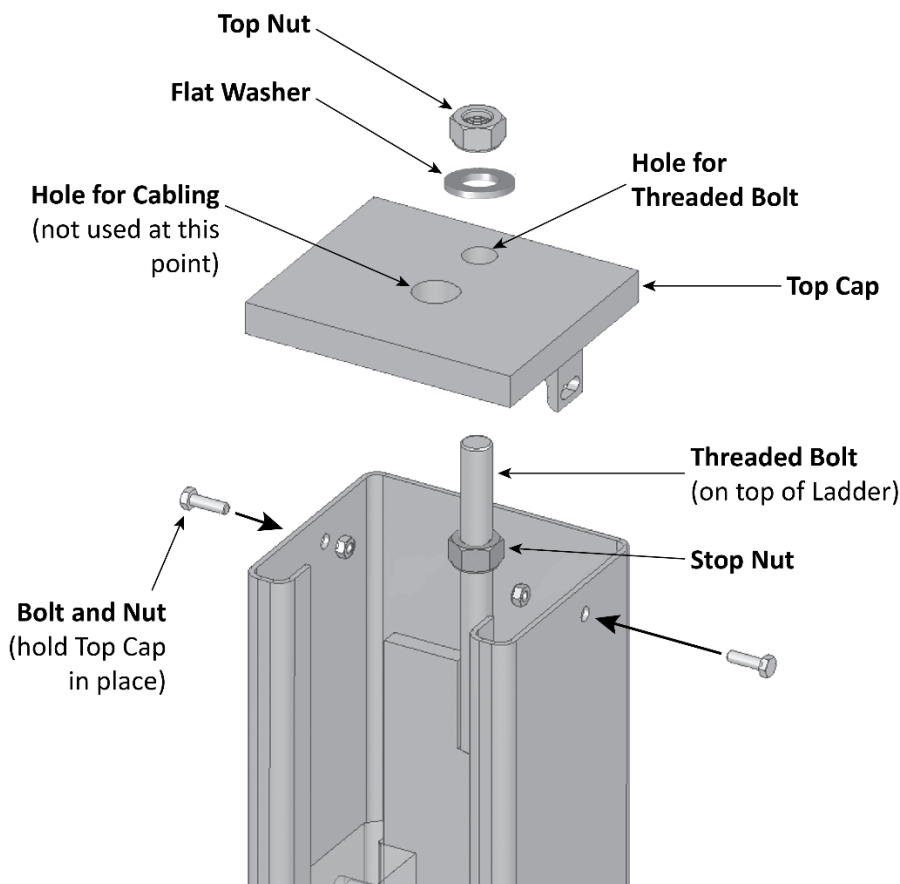

4. Put a Top Cap onto the top of the Post: put the Threaded Bolt on the top of the Ladder through the appropriate hole, put the tabs on the side of the Top Cap inside the Post, and secure the Top Cap on both sides with one Hex Head Bolt and one Nyloc Nut per side.
5. Once the Top Cap is secure, move the Stop Nut up until it contacts the underside of the Top Cap, then add a Flat Washer and Nyloc Nut to the top of the Top Cap and tighten. Hand tighten only.

You are looking for about an inch of thread above the top of the Top Nut.

**Note:** The other hole in the middle of the Top Cap is for the Lifting Cable, installed later.

6. Install the other three Top Caps the same way.

## Raising the Crosstubes

At this point in the installation you need to manually raise the Crosstubes, as this makes it easier to complete the rest of the installation tasks. Both Crosstubes need to be raised the exact same amount, to the exact same height.

### To raise the Crosstubes:

1. Using a Forklift or Shop Crane, carefully raise each Crosstube.

You probably want to raise the Crosstubes at least two feet off the ground, but it is up to you. Some people move them up enough to work under them, which can make it easier to route the Lifting Cables, Return Line, Air Lines, and Hydraulic Hose.

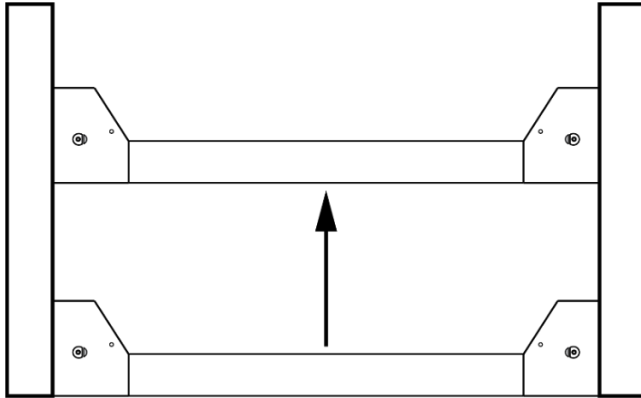

**Important:** The Slack Safety Locks will automatically engage when you raise the Crosstubes. They **cannot** be engaged as you continue with the installation, so *they must be disengaged*.

2. To disengage the Slack Safety Locks after raising a Crosstube: raise and hold one end of a Crosstube so the Primary and Slack Safety Locks are disengaged, push and hold the Sheave or the Steel Piece in towards the Ladder and the back of the Post (this moves the Slack Safety Lock so it cannot engage), lower the end of the Crosstube, then release the Sheave or Steel Piece.

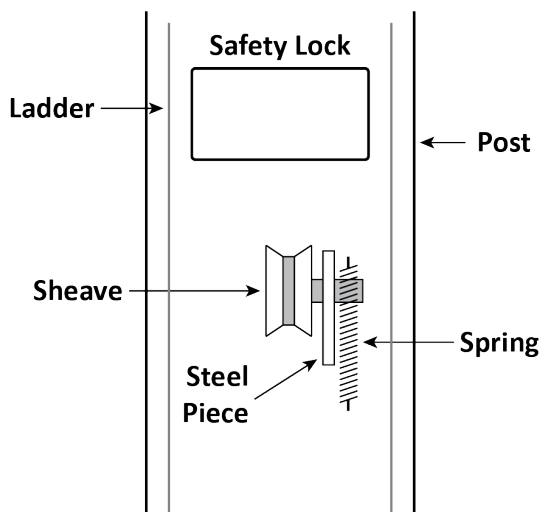

The Primary Safety Lock engages, but the Slack Safety Lock does *not*; this is what you want.

3. Disengage the other three Slack Safety Locks as done in Step 2.
4. Once both Crosstubes are raised, **all four Primary Safety Locks are engaged**, and all four Slack Safety Locks have been **disengaged**, you can continue with the installation.

---

## Securing the Ladders

Because it is much easier to secure the Ladders at the bottom of each Post **after** the Crosstubes have been raised, that procedure is described here.

**Note:** The following procedure assumes that the Ladders are in place and secured at the top. If this is **not** the case, return to [Installing the Ladders and Top Cap](#).

### To secure the Ladders:

1. Locate a Bolt, Washer, Spacer, second Washer, and Nut for each Ladder.

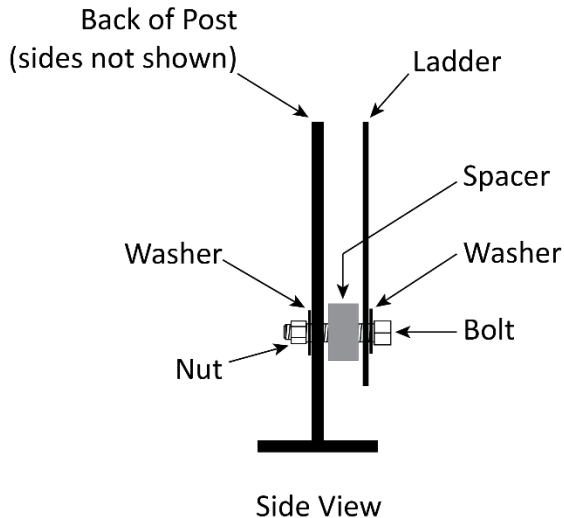

2. Put a Washer next to the Bolt head, then insert the Bolt just through the elongated hole near the bottom of the Ladder.
3. Put the Spacer into position between the Ladder and the back of the Post.
4. Push the Bolt through the Spacer and then through the back of the Post.
5. Take the second Washer and the Nut and install them on the end of the Bolt; secure the Nut.
6. Perform the same procedure to secure the other three Ladders on the Lift.

**Note:** Do not securely tighten the Top Nut at the top of the Top Cap at this point. The Top Nut and the Stop Nut will be used later to make sure the Lift is level. They can be securely tightened after you do the final leveling of the Lift; refer to [Final Leveling](#) for additional information.

**⚠ WARNING** Make sure all four Ladders are correctly installed and secured. If not, the Lift may not be able to hold a Vehicle, which is a danger to anyone under the Vehicle or around it.

7. Make sure the Primary Safety Locks are engaged.

**⚠ WARNING** Do not continue with the installation until you have visually confirmed that all four Primary Safety Locks are engaged. If they are not engaged, the Runways could move or fall, possibly causing personal injury (even death) or product damage.

## Removing Sheaves

In order to route the Lifting Cables, you need to remove the 10 Cable Sheaves on the underside of the Powerside Runway, the two Side Sheaves, and the four Gusset Sheaves and their Lock Pins.

When you remove the Sheaves, **keep all of the components together**. You will be reinstalling them at the same location, using the same components.

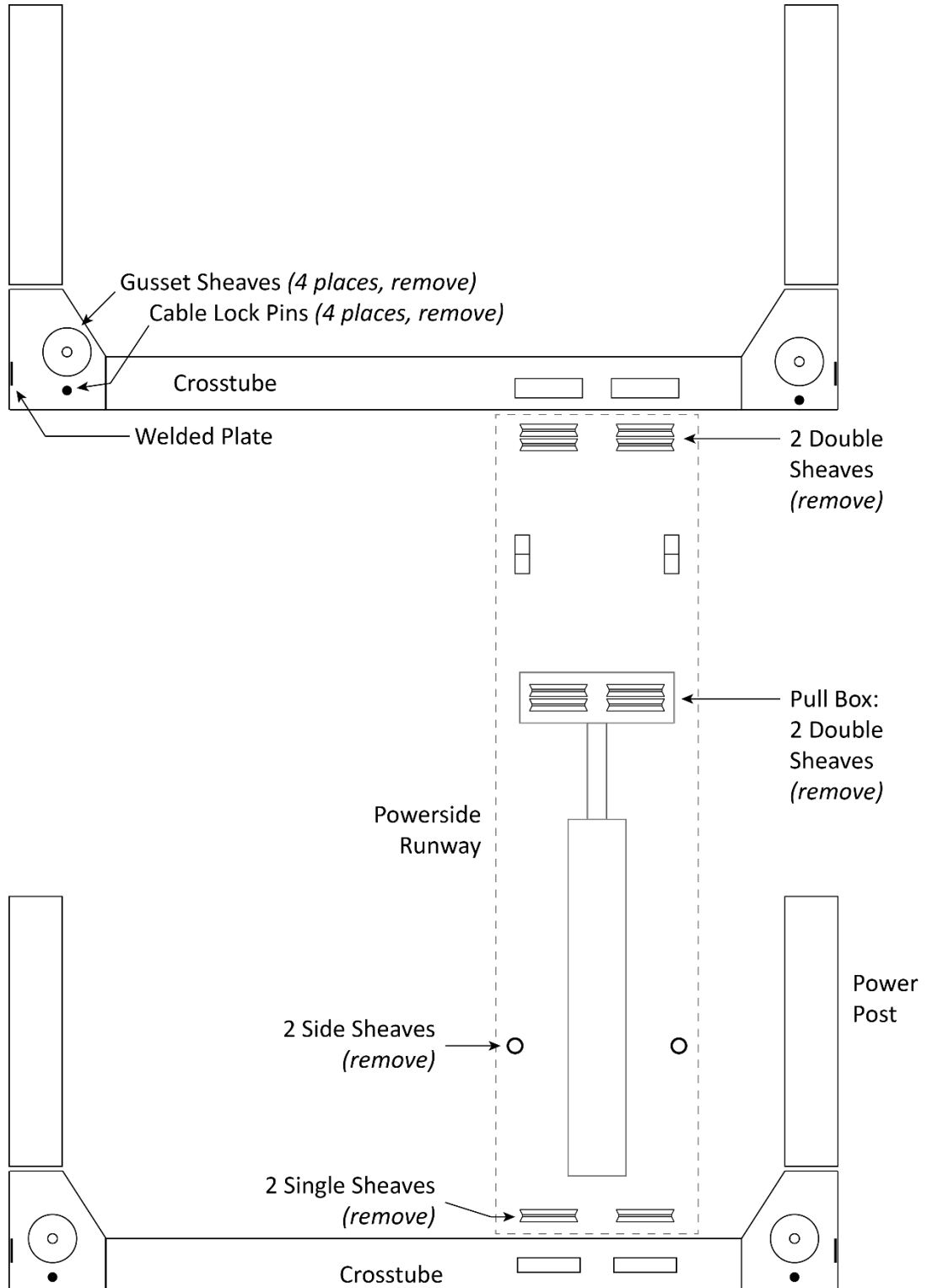

*Not necessarily to scale. Not all components shown. Combines top and side views.*

## Installing the Runways

Your Lift has two Runways:

- **Powerside Runway:** Has the Lift's Hydraulic Cylinder underneath it. Gets bolted into position. Has a hole on the outside (on the Cylinder end) that lets you route the Hydraulic Hose, Air Lines, and Return Line to the Power Unit. Lifting Cable routing ends under the Powerside Runway.
- **Offside Runway:** Gets bolted into position. Does not have a Hydraulic Cylinder under it, nor are there any Lifting Cables under it.

Orient the two Runways this way:

- Utility Rails on the inside
- Find the Powerside Runway by looking under the two Runways (only the Powerside Runway has a Hydraulic Cylinder underneath it) and put it next to the Power Post.

There is also an ~1.5 inch wide hole in the outside of the Powerside Runway near the Power Post. There are other holes in the Runways, but they are smaller and used with accessories only.

The following drawing shows the correct orientation of the Runways for both Power Post locations.

The Ramp locations do not change based on Power Post location, but the location and orientation of the Powerside Runway does.

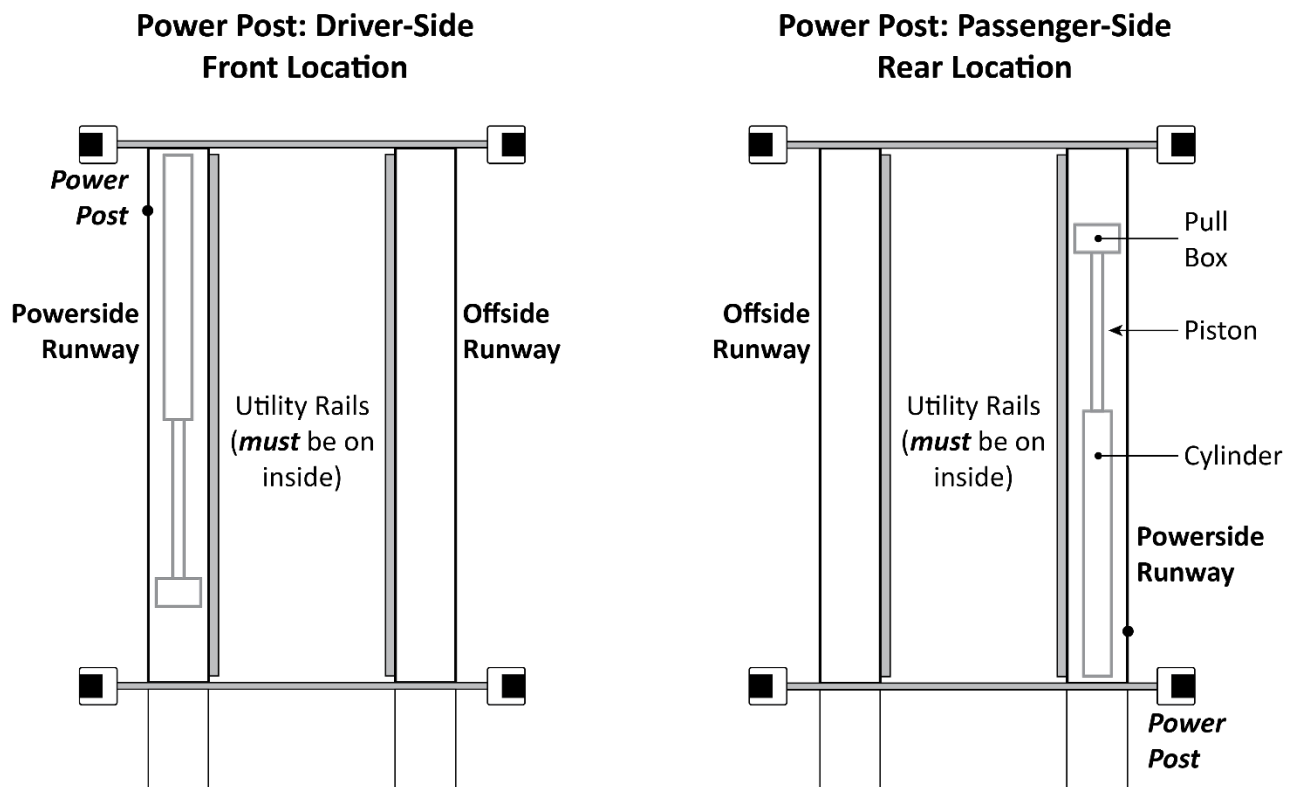

*Not necessarily to scale. Not all components shown. Tops of Runways not shown.*

---

Use a Forklift or Shop Crane to raise the Runways and move them into position.

 **WARNING** Pay close attention when moving the Runways into position; they are heavy and long, and could shift position or fall, potentially causing serious injury.

**To install the Runways:**

1. Correctly orient the Powerside Runway and the Offside Runway.  
See the previous page for more information.
2. On the underside of the Powerside Runway, make sure the Sheaves have been removed.
3. Use a Forklift or Shop Crane to pick up the Powerside Runway and move it into place on the Powerside of the Lift.

***Make sure the Utility Rail is on the inside.***

4. Bolt the Powerside Runway into place, two Bolts on each end going into the Crosstubes.
5. Using a Forklift or Shop Crane, pick up the Offside Runway and move it into place.

***Make sure the Utility Rail is on the inside.***

6. Bolt the Offside Runway into place.
7. Make sure the Primary Safety Locks are engaged.

 **WARNING** Do not continue with the installation until you have visually confirmed that all four Primary Safety Locks are engaged. If they are not engaged, the Runways could move or fall, possibly causing personal injury (even death) or product damage.

---

## Installing the First End of the Flex Tube

The Flex Tube is a flexible, black tube that attaches to a hole on the Powerside Runway on one end and to the bottom of the Flex Tube Bracket Plate (near the Power Unit) on the other end.

The Flex Tube consolidates and protects three lines that come out from under the Powerside Runway on their way to the Power Unit: the Return Line, the Air Line, and the Hydraulic Hose.

The Flex Tube is about 52 in / 1,320 mm long and about 1.5 in / 38 mm wide. Both ends are the same.

Installation of the Flex Tube is done in two parts: the first part is done after the Runways are installed (now), the second part after the Power Unit (and the Flex Tube Bracket Plate) is installed (later).

The following drawing shows the Flex Tube.

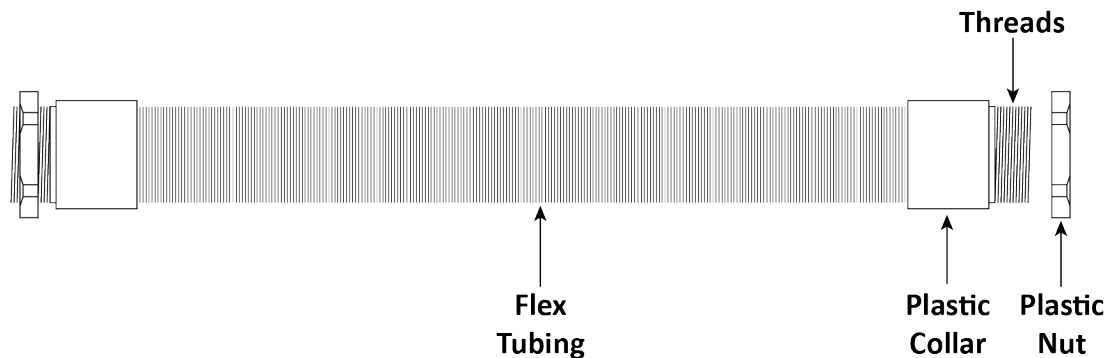

*Not necessarily to scale. Not all components shown.*

### To install the Flex Tube to the Powerside Runway:

1. Unscrew the Plastic Nut from one end of the Flex Tube. It does not matter which end you use.
2. Holding the Flex Tube by the Plastic Collar, put the Threads on the end of the Flex Tube through the hole on the side of the Powerside Runway.

The hole is about 1.5 in / 38 mm wide.

The Threads go into the hole until they are accessible from the inside, the rest of the Flex Tube stays outside.

3. On the inside of the Powerside Runway, screw the Plastic Nut back onto the Threads of the Flex Tube and tighten it.
4. Let the other end of the Flex Tube hang in place for now.



---

## Routing the Lifting Cables

Before routing the Lifting Cables, you need to know the following:

- BendPak strongly recommends using gloves when working with the Lifting Cables.
- Each Lift has four Lifting Cables. All four are different lengths. Each Lifting Cable is the right length for one path. If you use a Lifting Cable in the wrong path, it will be either too short or too long.
- All Lifting Cables have a Button end and a Threaded end.



### Button end.

Attaches at  
Cable Anchor Plate

### Threaded end.

Attaches at  
top of Post

- The Threaded End of each Lifting Cable attaches at the top of a Post. Before routing each Lifting Cable, remove the Nut and Washer at the Threaded End.
- The Button End of each Lifting Cable attaches at the Cable Anchor Plate on the side of the Powerside Runway.

See the drawings on the next two pages for the path each Lifting Cable takes.

- There are several kinds of Sheaves: Cable Sheaves (10), Gusset Sheaves (4), and Side Sheaves (2). All Sheaves should be removed before routing the Lifting Cables.
- There are 10 Cable Sheaves: four in the Pull Box, four on one end of the Powerside Runway adjacent to the Large Windows, and two on the other end of the Powerside Runway adjacent to the Small Windows.
- There are four Gusset Sheaves, one in each Crosstube Gusset; each has a Lock Pin that also needs to be removed.
- There are two Side Sheaves, one on each side of the Powerside Runway.
- All Sheaves come installed. They should have been removed earlier in the installation process, just before installing the Runways. If any of the Sheaves are still in place, remove them before you start routing the Lifting Cables.
- When you removed the Sheaves, the components needed to put them back into place should have been kept together. It is important to reinstall the Sheaves at the same location from which you removed them, using the same components.
- The four Lifting Cables for the **HD-7P** are:
  - **A: 5086** mm / 18.25 feet / 200.25 inches (part number 5595014)
  - **B: 6494** mm / 21.5 feet / 255.5 inches (part number 5595015)
  - **C: 9290** mm / 30.5 feet / 365.75 inches (part number 5595012)
  - **D: 10674** mm / 35.25 feet / 420.25 inches (part number 5595013)
- The four Lifting Cables for the **HD-7W** are:
  - **A: 5099** mm / 16.75 feet / 200.75 inches (part number 5595473)
  - **B: 6724** mm / 22.75 feet / 264.75 inches (part number 5595454)
  - **C: 9271** mm / 35.75 feet / 365 inches (part number 5595917)
  - **D: 10897** mm / 33 feet / 429 inches (part number 5595022)
- All Lifting Cables have tags that show their length in millimeters and their Part Number.

The following drawing shows the components involved in routing the Lifting Cables.

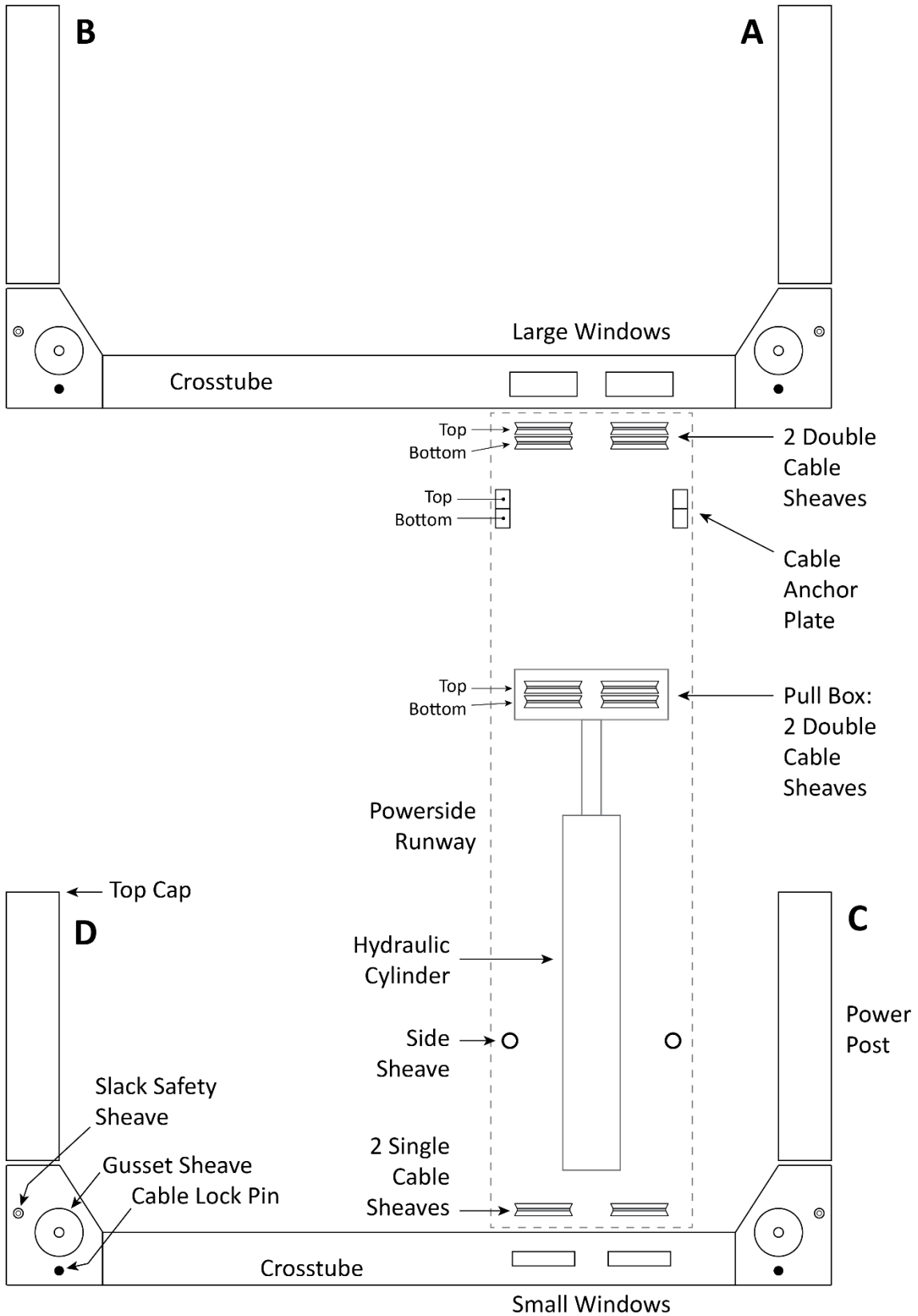

*Not necessarily to scale. Not all components shown.*

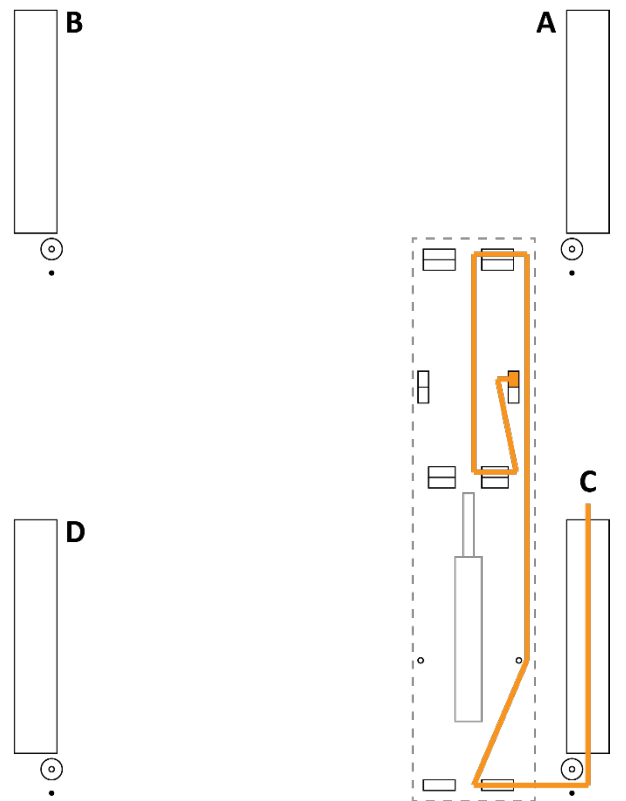
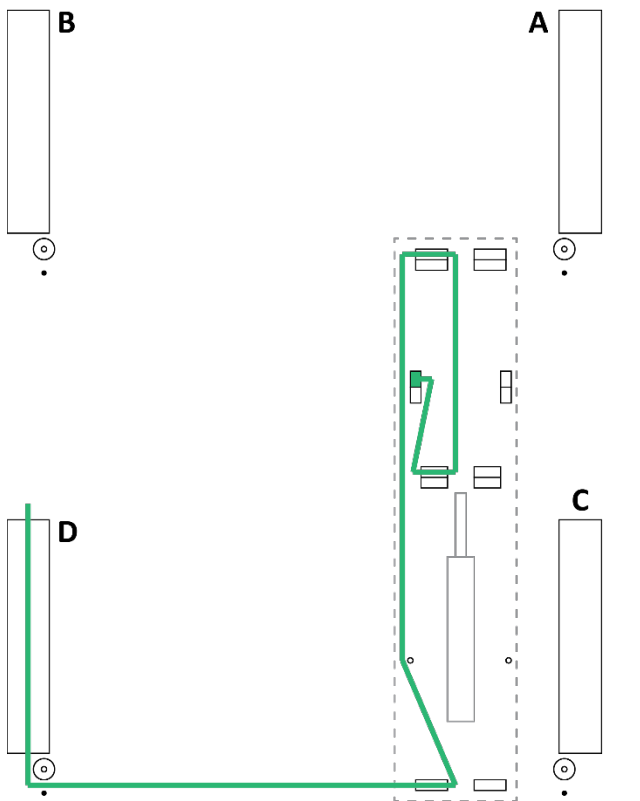
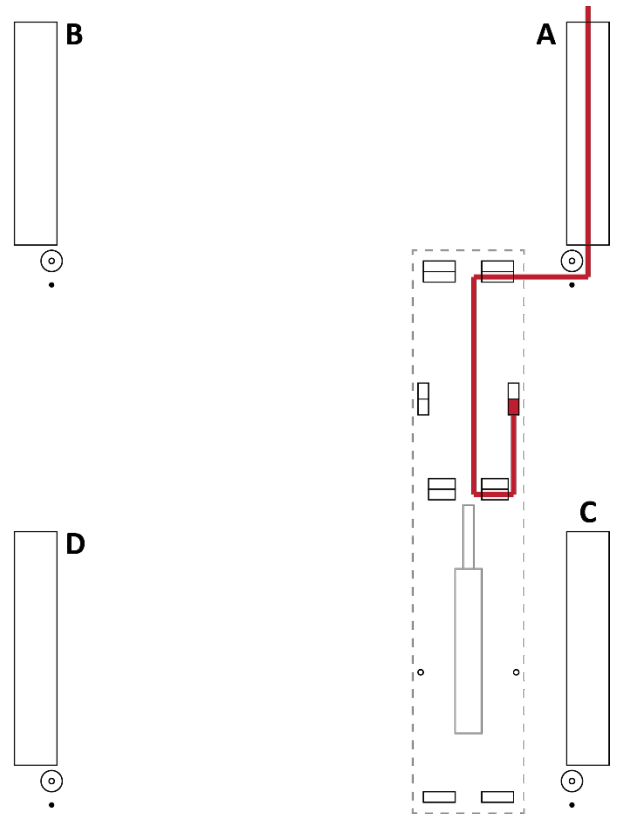
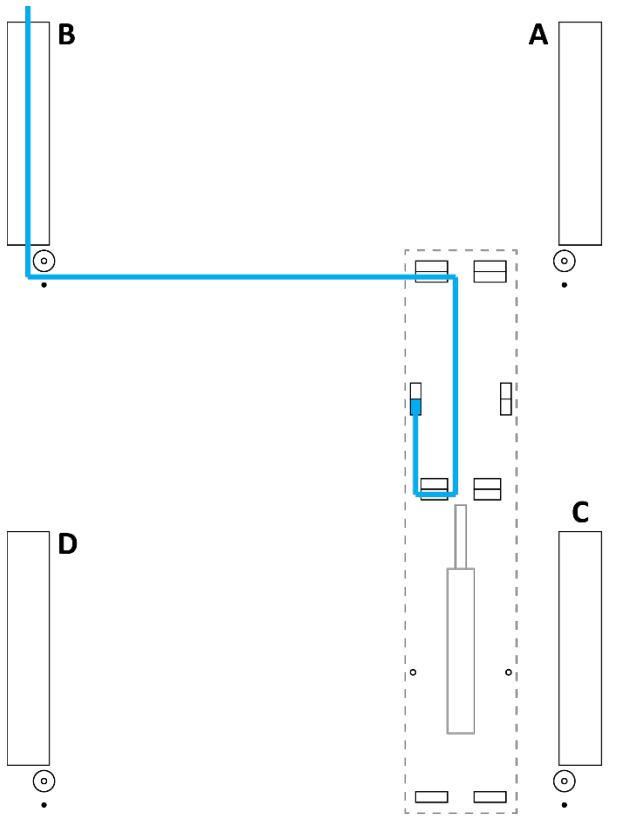

*Not necessarily to scale. Not all components shown.*

Before routing your Lifting Cables, you need to extend the Piston of the Hydraulic Cylinder.

**To extend the Piston:**

1. Remove the Shipping Plug from the Return Line Connector.  
The Return Line Connector is on the Hydraulic Cylinder on the end away from the Pull Box.
2. Attach an air pressure source to the Return Line Connector.
3. Use the air pressure to extend the Hydraulic Cylinder's Piston and Pull Box.

**Do not exceed 50 PSI.**

If the Hydraulic Cylinder does not move, stop using air pressure; instead, use a pulling device (such as a Come Along Tool) to extend the Piston and Pull Box. Be careful not to damage the Piston or the Pull Box.

4. Reinstall the Shipping Plug to the Return Line Connector.

The following procedure assumes you have nearby the four Lifting Cables and the Sheaves you removed before you installed the Runways.

Use the drawings on the previous two pages in conjunction with this procedure.

**To route Lifting Cables A and C:**

1. **Starting with Lifting Cable A**, move the entire thing to just under the Large Window it goes through, near the bottom of Post A.

Check the label to make sure you have the correct Lifting Cable.

2. Remove the Nut and Washer from the Threaded End, if not already done.
3. Route the Threaded End of Lifting Cable A into its Large Window on the Crosstube, push it toward the Power Post, then pull the Threaded End out of the Crosstube at the bottom of the Gusset.

You can access the Large Window on the Crosstube because the double Cable Sheave has been removed. If it is not removed, it blocks access to the Large Window.

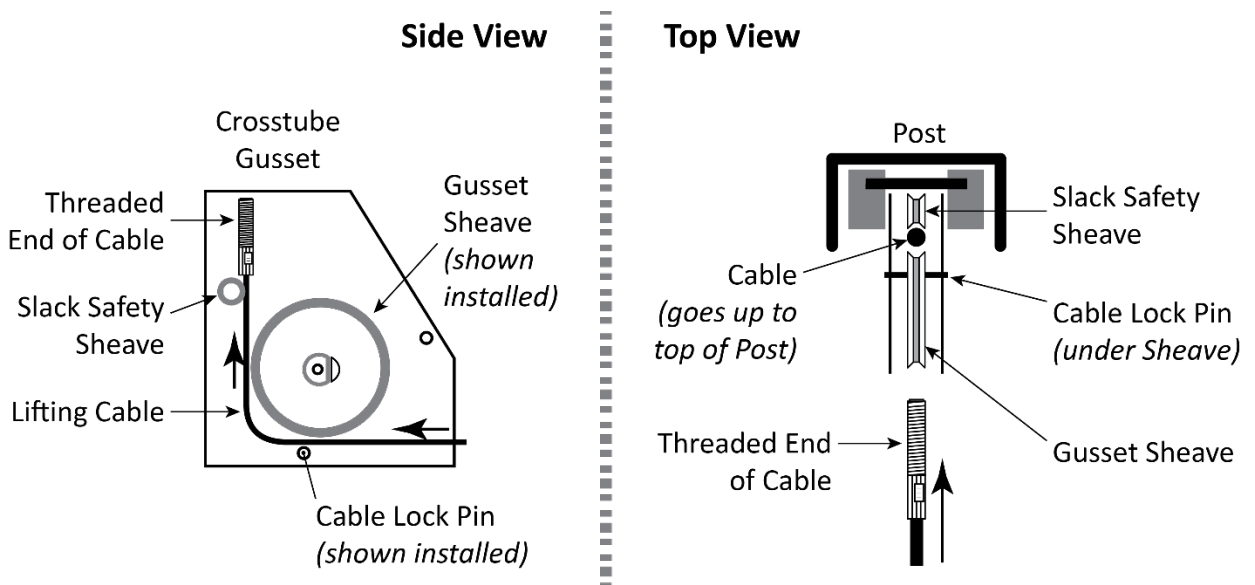

*Not necessarily to scale. Not all components shown. Includes side view and top views.*

4. Route the Threaded End of Lifting Cable A **under** where the Gusset Sheave will go when it is reinstalled, then route it up towards the top of the Post past the top of the Crosstube Gusset.

---

When you start routing the Lifting Cable up, it **must** go between the Gusset Sheave and the Slack Safety Sheave, as shown in the drawing above.

**Important:** When routing a Lifting Cable in its Post, it must go **under** where the Gusset Sheave will go when the Gusset Sheave is reinstalled and then, when it heads up towards the top of the Post, it must be between where the Gusset Sheave will go and where the Slack Safety Sheave already is. If the Cable is **not in this exact location**, the Slack Safeties will **not** work correctly later on.

5. With the Lifting Cable in place, reinstall the Gusset Sheave and the Cable Lock Pin in Post A.
6. Double check to make sure Lifting Cable A is correctly positioned: in the Gusset Sheave, between the Gusset Sheave and the Slack Safety Sheave, with the Cable Lock Pin **under** it.
7. Push the Threaded End of Lifting Cable A up to and through the Top Cap (at the top of the Post) and **hand tighten** it in place with the Nut and Washer you removed earlier.

You only want to hand tighten the Nut at this point so that there is a little play in the cabling. We will securely tighten all four Nuts later in the installation procedure.

**Note:** The Threaded end of Lifting Cable A should go just a little bit through the Top Cap. If it is way too long or way too short, you probably have the wrong Lifting Cable. If it is just a few inches short, then the Piston on the Hydraulic Cylinder may not have been pulled out far enough.

8. Make sure the Button End and the unrouted part of Lifting Cable A is under the Large Window, near the bottom of Post A.
9. **Switching to Lifting Cable C**, repeat Steps 1 through 6 for Lifting Cable C, starting at the Small Window near the bottom of Post C.
10. Once the Threaded End of Lifting Cable C is secured at its Top Cap, return to the Small Window at the bottom of Post C.
11. Under the Powerside Runway, move the rest of Lifting Cable C towards where the Side Sheave goes on the Post C side of the Runway.
12. Return to the Small Window and reinstall the Cable Sheave.
13. Double check to make sure Lifting Cable C is correctly positioned in the Cable Sheave in the Small Window.
14. Route Lifting Cable C into the Side Sheave and then on towards the Large Window, which is at the other end of the Runway.

The Side Sheave was removed earlier so you can get the Lifting Cable into place.

15. Reinstall the Side Sheave.

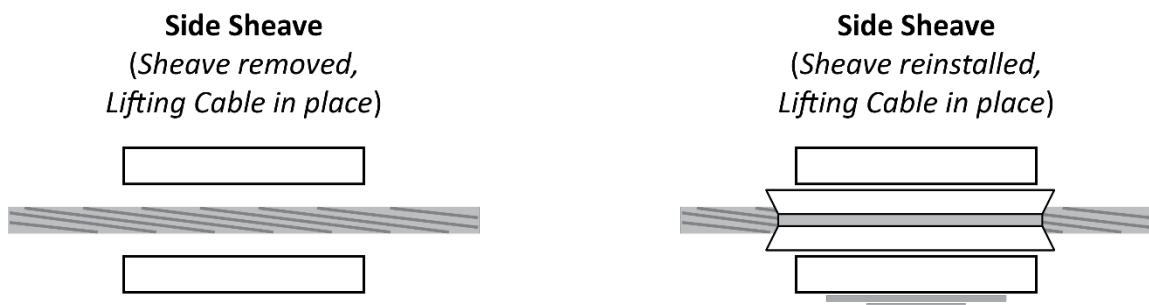

*Not necessarily to scale. Not all components shown.*

16. Route Lifting Cable C all the way to the other end of the Runway, where Lifting Cable A is, making sure to route it over the retaining section of the Cable Anchor Plate (shown below).

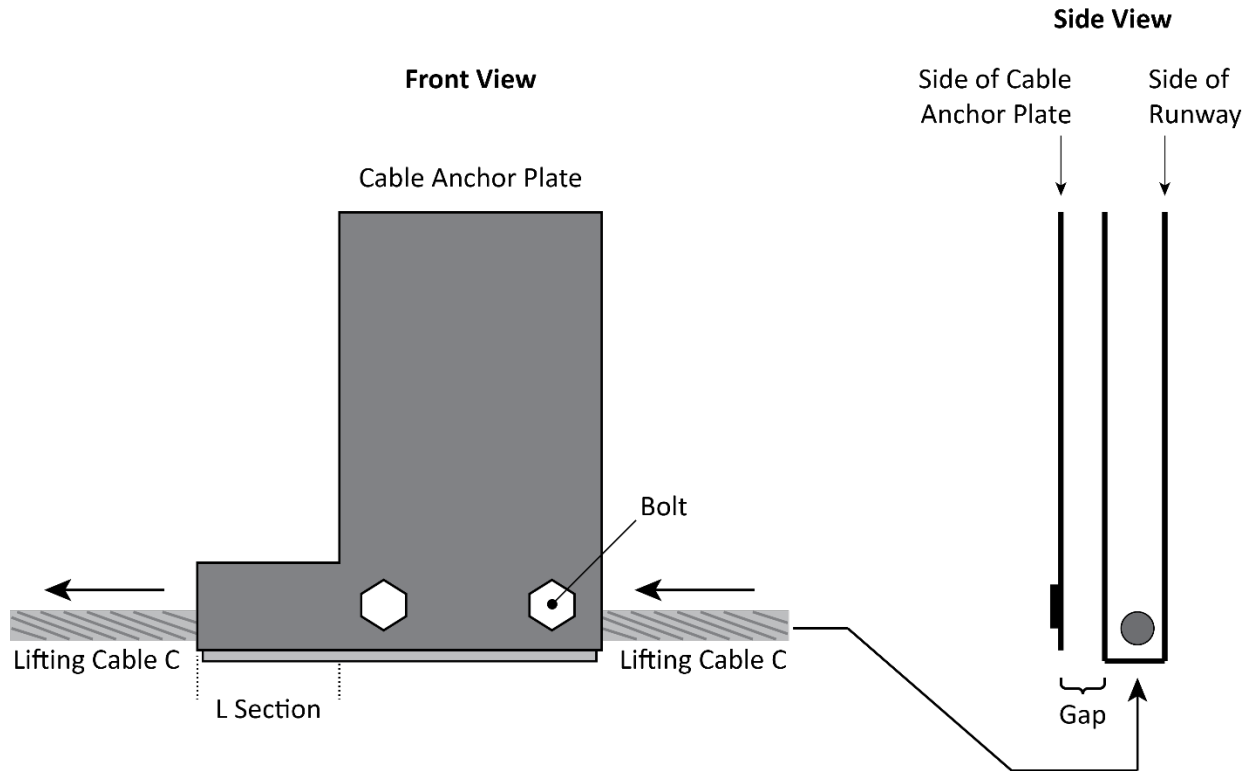

*Not necessarily to scale. Not all components shown.*

17. Gather the unrouted portions of Lifting Cables **A and C**, making sure to orient Lifting Cable C above Lifting Cable A.
18. Push Lifting Cables A and C into the space where the double Cable Sheave goes (in the Large Window) and move the Button Ends towards the Pull Box.

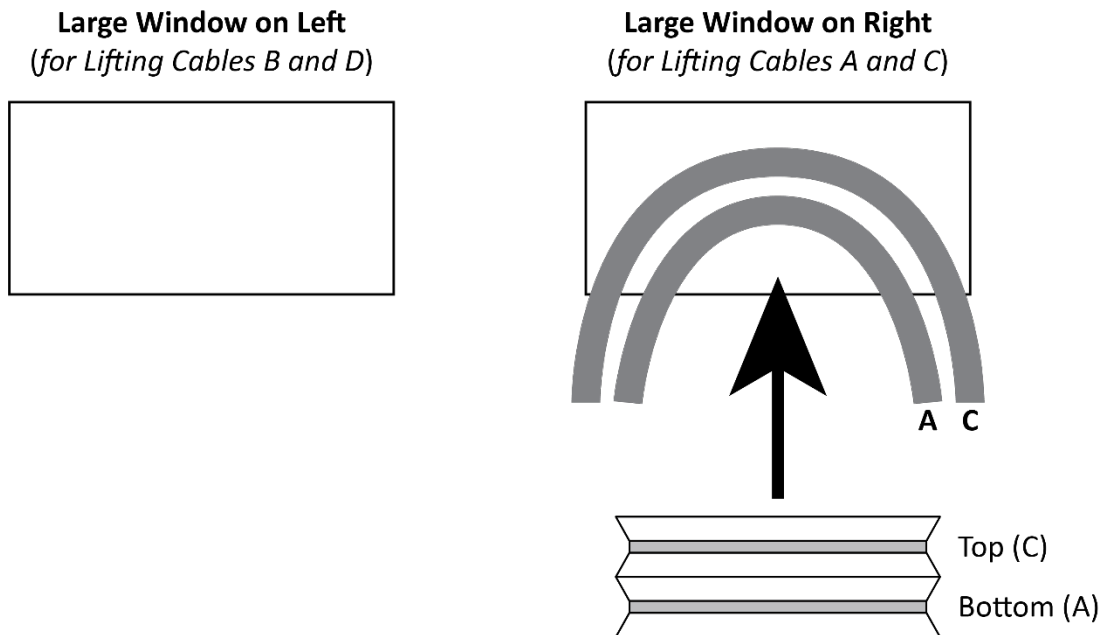

*Not necessarily to scale. Not all components shown.*

19. Reinstall the double Cable Sheave.

Make sure to keep both Lifting Cables: in their correct positions (C on top, A on the bottom), sitting correctly in the Sheaves, and free from any entanglements.

20. Route Lifting Cables A and C towards the Pull Box.

21. Put both Lifting Cables into the correct side of the Pull Box, with the Button Ends of both heading back out of the Pull Box.

22. Reinstall the double Cable Sheave in the Pull Box, again making sure to keep both Lifting Cables: in their correct positions (C on top, A on the bottom), sitting correctly in the Sheaves, and free from any entanglements.

23. Route the Button Ends of both Lifting Cables A and C towards the Cable Anchor Plate on the side of the Runway.

24. Unscrew the Bolts at the bottom of the Cable Anchor Plate, slide the Lifting Cables into position in the Cable Anchor Plate (in the Gap, over the L section, back up against the Cable Anchor Plate, and with C on top and A on the bottom), and then reinstall the Bolts.

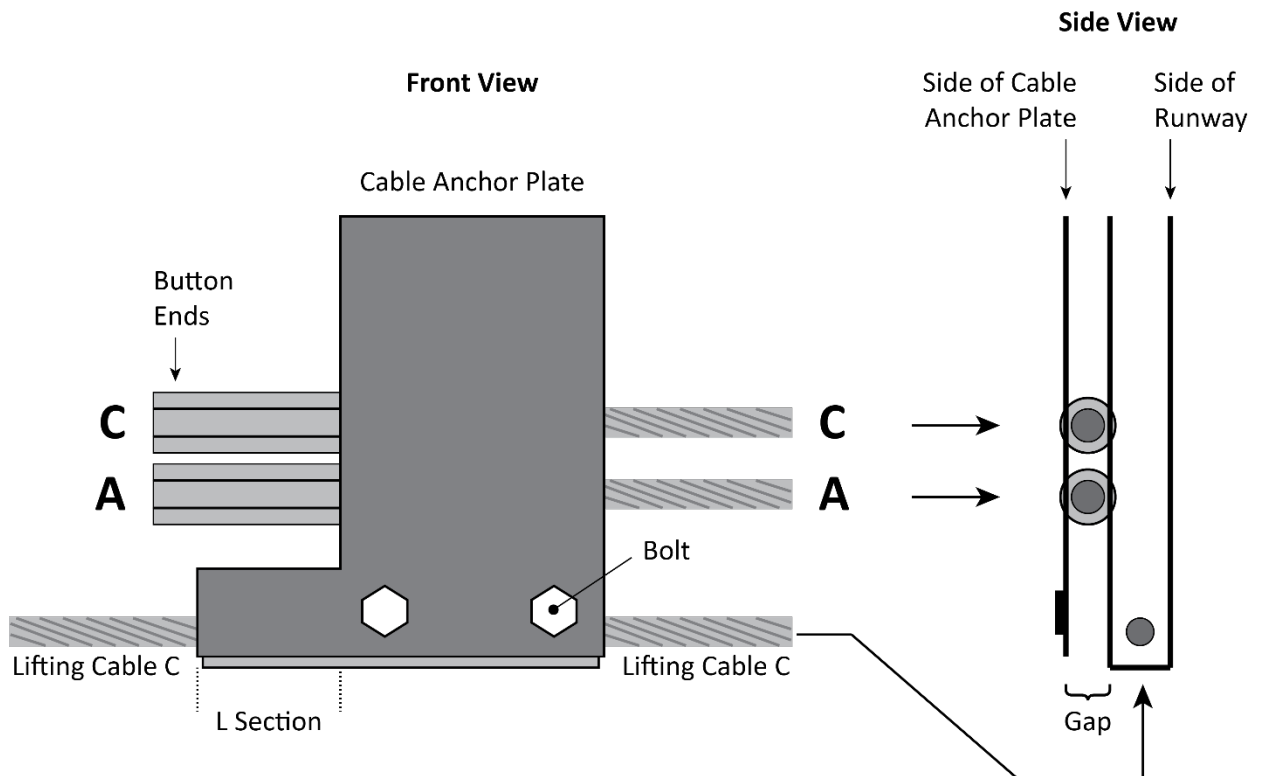

*Not necessarily to scale. Not all components shown.*

**Note:** If Lifting Cables A and C are stretched tight and you cannot get the Button Ends over the L section of the Cable Anchor Plate, you can temporarily remove the double Cable Sheave in the Pull Box to get a little slack. This issue does not happen often; there is usually slack in the Lifting Cables, depending on how far the Piston was extended.

25. If you see slack in the Lifting Cables, this is normal. It will go away when you start using the Lift.

---

Routing Lifting Cables B and D is the same process as routing Lifting Cables A and C, just to the other two Posts and using a different set of Sheaves. Refer to the drawings in the previous section.

**To route Lifting Cables B and D:**

1. **Starting with Lifting Cable B**, move it to just under the Large Window it goes through, near the bottom of Post B.

Check the label to make sure you have the correct Lifting Cable.

2. Remove the Nut and Washer from the Threaded End.
3. Route the Threaded End of Lifting Cable B into its Large Window on the Crosstube, push it toward the Power Post, then pull the Threaded End out of the Crosstube at the bottom of the Gusset.

You can access the Large Window on the Crosstube because the double Cable Sheave has been removed. If it is not removed, it blocks access to the Large Window.

4. Route the Threaded End of Lifting Cable B **under** where the Gusset Sheave will go when it is reinstalled, then route it up towards the top of the Post past the top of the Crosstube Gusset.

When you start routing the Cable up, it **must** be between the Gusset Sheave and the Slack Safety Sheave, as shown in the drawing above.

**Important:** When routing a Lifting Cable in its Post, it must go **under** where the Gusset Sheave will go when the Gusset Sheave is reinstalled and then, when it heads up towards the top of the Post, it must be between where the Gusset Sheave will go and where the Slack Safety Sheave already is. If the Cable is **not in this exact location**, the Slack Safeties will **not** work correctly later on.

5. Reinstall the Gusset Sheave and the Cable Lock Pin in Post B.
6. Double check to make sure Lifting Cable B is correctly positioned: in the Gusset Sheave, between the Gusset Sheave and the Slack Safety Sheave, with the Cable Lock Pin **under** it.
7. Push the Threaded End of Lifting Cable B up to and through the Top Cap (at the top of the Post) and **hand tighten** it in place with the Nut and Washer you removed earlier.

You only want to hand tighten the Nut at this point so that there is a little play in the cabling. We will securely tighten all four Nuts later in the installation procedure.

**Note:** The Threaded end of Lifting Cable B should go just a little bit through the Top Cap. If it is way too long or way too short, you probably have the wrong Lifting Cable. If it is just a few inches short, then the Piston on the Hydraulic Cylinder may not have been pulled out far enough.

8. Make sure the Button End and the unrouted part of Lifting Cable B is under the Large Window, near the bottom of Post B.
9. **Switching to Lifting Cable D**, repeat Steps 1 through 6 for Lifting Cable D, starting at the Small Window near the bottom of Post D.
10. Once the Threaded End of Lifting Cable D is secured at its Top Cap, return to the Small Window at the bottom of Post D.
11. Under the Powerside Runway, move the rest of Lifting Cable D towards where the Side Sheave goes on the Post D side of the Runway.
12. Return to the Small Window and reinstall the Cable Sheave.
13. Double check to make sure Lifting Cable D is correctly positioned in the Cable Sheave in the Small Window.



- 
14. Route Lifting Cable D into the Side Sheave and then on towards the Large Window (at the other end of the Powerside Runway).

The Side Sheave was removed earlier so you can get the Lifting Cable into place.

15. Reinstall the Side Sheave.
16. Route Lifting Cable D all the way to the other end of the Runway, where Lifting Cable B is, making sure to route it over the retaining section of the Cable Anchor Plate (shown below).
17. Gather the unrouted portions of Lifting Cables **B and D**, making sure to orient Lifting Cable D above Lifting Cable B.
18. Push Lifting Cables B and D into the space where the double Cable Sheave goes (in the Large Window) and move the Button Ends towards the Pull Box.
19. Reinstall the double Cable Sheave.  
Make sure to keep both Lifting Cables: in their correct positions (D on top, B on the bottom), sitting correctly in the Sheaves, and free from any entanglements.
20. Route Lifting Cables B and D towards the Pull Box.
21. Put both Lifting Cables into the correct side of the Pull Box, with the Button Ends of both heading back out of the Pull Box.
22. Reinstall the double Cable Sheave in the Pull Box, again making sure to keep both Lifting Cables: in their correct positions (D on top, B on the bottom), sitting correctly in the Sheaves, and free from any entanglements.
23. Route the Button Ends of both Lifting Cables B and D towards the Cable Anchor Plate on the side of the Runway.
24. Unscrew the Bolts at the bottom of the Cable Anchor Plate, slide the Lifting Cables into position in the Cable Anchor Plate (in the Gap, over the L section, back up against the Cable Anchor Plate, and with D on top and B on the bottom), and then reinstall the Bolts.

**Note:** If Lifting Cables B and D are stretched tight and you cannot get the Button Ends over the L section of the Cable Anchor Plate, you can temporarily remove the double Cable Sheave in the Pull Box to get a little slack. This issue does not happen often; there is usually slack in the Lifting Cables, depending on how far the Piston was extended.

25. If you see slack in the Lifting Cables, this is normal. It will go away when you start using the Lift.

---

## Working with Compression Fittings and Tubing

Your Lift comes with a roll of ¼ inch, black, polyethylene Tubing (also called Poly-Flo® Tubing) that is used with Compression Fittings in two ways: for the Return Line and for the Air Lines.

**Important:** While both lines use Tubing and Compression Fittings, the Return Line and Air Lines are used for completely separate purposes; do not connect the two together.

**Note:** Compression Fittings are different from Hydraulic Fittings. This section covers Compression Fittings only.

The components involved with Compression Fittings include:

- **¼ inch, black, polyethylene Tubing.** You use a single piece of Tubing for the Return Line. The Air Lines require multiple Tubing pieces. Create the Tubing pieces for both the Return Line and the Air Lines by cutting lengths from the long roll of Tubing supplied with your Lift.
- **Elbow Compression Fittings.** The Return Line uses two Elbow Compression Fittings, one at each end.
- **Tee Compression Fittings.** The Air Lines require three Tee Compression Fittings.
- **Nuts, Ferrules, Rods, and Threads.** Each connector on Elbow and Tee Compression Fittings have a Nut, Ferrule, Rod, and Threads (see drawing below). The Nut holds the Tubing and Fitting together. The Ferrule compresses when you tighten the Nut on the Threads to make a secure connection. The Rod goes inside the Tubing so that nothing leaks out.

The following drawing shows the components of a connector on a Tee Compression Fitting.



**Important:** *Ferrules can only be tightened once.* When you tighten the Nut on the Threads, the Ferrule gets compressed; it literally changes shape and **cannot** be used again.

### To connect Tubing to a Compression Fitting:

1. Push the Tubing through the Nut and over the Rod.  
Do not push hard; you only need the Tubing to go a little way over the Rod. You cannot see the Ferrule at this point, but the Tubing must go through the Ferrule and over the Rod.
2. Slide the Nut on the Tubing **away from the Fitting**, if the Nut is still on the Threads, unscrew it from the Threads and then slide it away from the Fitting. See the drawing above.
3. Slide the Ferrule over the Tubing, away from the Fitting and towards the Nut.
4. With the Nut and the Ferrule out of the way, push the Tubing further over the Rod until it stops.
5. Slide the Ferrule and the Nut back to the Threads on the Fitting.  
The Ferrule goes around the Rod and under the Threads. The Nut goes onto the Threads.
6. Tighten the Nut.

Remember that the Ferrule can only be used once; do not tighten the Nut until everything is ready.

## Installing the Air Lines

This section describes how to install the Air Lines, but not how to connect them to the Power Unit (as it is not yet installed).

The Air Lines use air pressure to disengage the Safety Locks so you can lower the Runways.

The Air Lines run from near the Power Unit, where most people set up their Pushbutton Air Valve, to the Air Cylinder on each Post. All four Air Cylinders must be set up correctly or you will not be able to get your Runways off their Safety Locks.

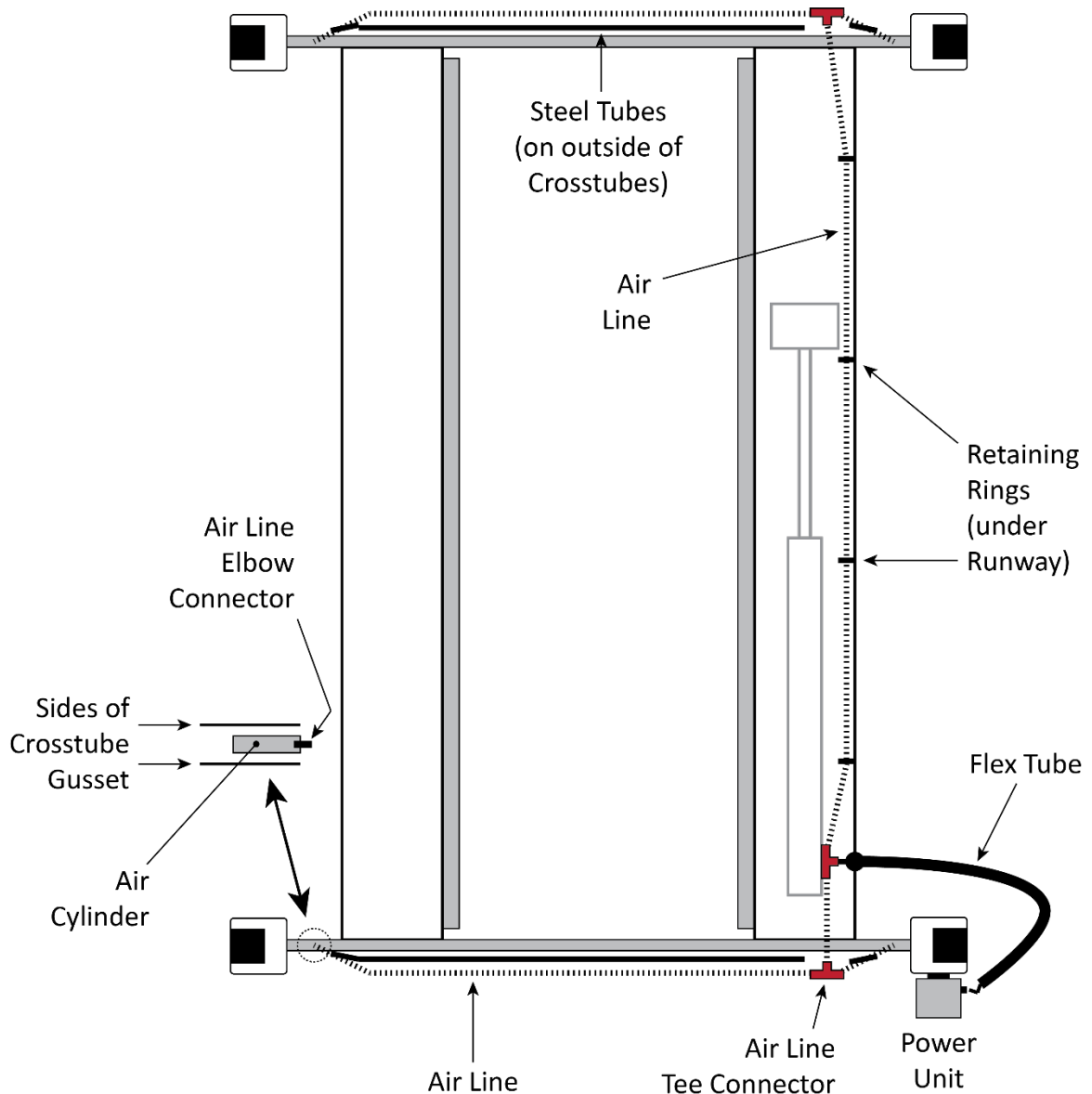

*Drawing not to scale. Some components not shown. Air Lines shown outside Steel Tubes for clarity.*

---

You will need more of the ¼ inch, black, polyethylene Tubing that came with the Lift and three Air Line Tee Connectors to install the Air Lines.

An Air Supply (3 to 25 cfm at 50 to 150 psi) is required to disengage the Safety Locks. Regulate the line to a maximum pressure of 150 psi.

**⚠ CAUTION** Do not let the Air Supply exceed 150 psi; the Air Lines could burst or the Safety Locks malfunction.

The Air Line Elbow Connectors on the Air Cylinders come installed from the factory.

**Important:** Do not confuse the Air Lines with the Return Line. They use the same Tubing and fittings, but they are used for completely different things; the two systems **must not** be connected to each other.

### **To install the Air Lines:**

1. Find the roll of supplied ¼ inch, black, polyethylene Tubing and three Air Line Tee Connectors.
2. Measure the distances for each of the seven (7) Tubing pieces you will need (see the drawing on the previous page).
3. Cut seven pieces of Tubing to the measured lengths from the roll of Tubing.
4. Connect the various pieces of Tubing to the Air Line Tee Connectors on the Lift.

Refer to the drawing on the previous page for the locations of the Tubing pieces.

***Make sure to position the three Air Line Tee Connectors as shown in the drawing.***

Also make sure to route the long Tubing piece that goes under the Powerside Runway through the Retaining Rings. You need to make sure the Air Lines stay out of the way of the Lifting Cables.

**⚠ CAUTION** Make sure to route the Tubing pieces on the **outside** of the Front and Rear Crosstubes *through the Steel Tubes* on the Crosstubes. This keeps the Tubing and the Tee Connectors from being disturbed as you use the Lift. This is important, because if the Air Lines are disturbed, the Safety Locks on the Lift may not work correctly. If you notice that Tubing has become disconnected from an Air Line Tee Connector, take the Lift out of service and get the Air Lines fixed.

Refer to **Working with Compression Fittings and Tubing** for more information about connecting the Tubing to the Air Line Tee Connectors.

5. Leave the Power Unit end of the Air Line hanging out of the Flex Tube for now. It will be connected to the Pushbutton Air Valve later in the installation process.

---

## Installing the Hydraulic Hose

The Hydraulic Hose moves Hydraulic Fluid from the Power Unit to the Hydraulic Cylinder.

To install the Hydraulic Hose, you will need:

- **The Hydraulic Hose.** The Curved end attaches to a fitting on the Hydraulic Cylinder and the Straight end attaches to a fitting on the Power Unit.
- **One JIC to NPT hydraulic fitting.** The JIC end attaches to the Curved end of the Hydraulic Hose and the NPT end to the Hydraulic Cylinder.
- **One JIC to ORB hydraulic fitting.** The JIC end attaches to the Straight end of the Hydraulic Hose and the ORB end to the Power Unit. Connected later in the installation.

The following drawing shows how to connect the Curved End of the Hydraulic Hose to the Hydraulic Cylinder.

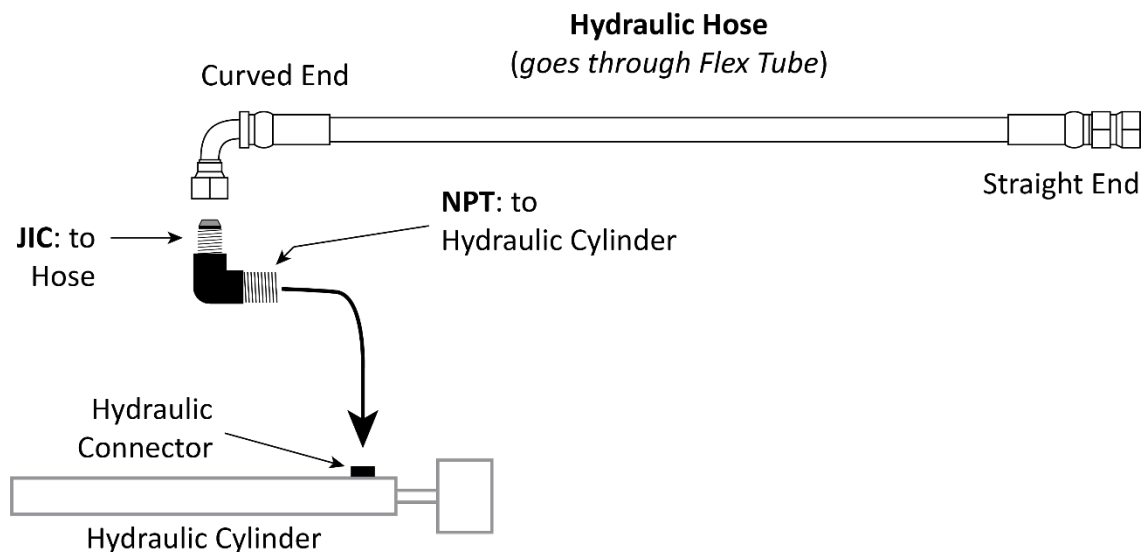

*Drawing not to scale. Not all components shown. Some components exaggerated for clarity.*

### To install the Hydraulic Hose:

1. Find the Hydraulic Hose and the JIC-to-NPT hydraulic fitting.
2. Push the Hydraulic Hose through the Flex Tube with the Curved end going to the Hydraulic Cylinder and the Straight end going to the Power Unit.
3. On the Hydraulic Cylinder, remove the Shipping Plug from the connector at the Piston / Pull Box end.
4. Attach the NPT connector (of the JIC-to-NPT Fitting) to the Hydraulic Connector on the Hydraulic Cylinder (where you just removed the Shipping Plug) and tighten it.  
  
Leave the JIC connector pointing up; this will help keep the Hydraulic Hose up and away from where the Lifting Cables will be installed.
5. Attach the Curved end of the Hydraulic Hose to the JIC connector that is facing up and tighten it.
6. Leave the Straight end of the Hydraulic Hose coming out of the Flex Tube; it will be connected to the Power Unit later in the installation.

---

## Installing the Return Line

The Return Line takes excess Hydraulic Fluid coming out of the Hydraulic Cylinder and sends it back into the Fluid Reservoir on the Power Unit.

The Return Line is a single piece of ¼ inch, black, polyethylene Tubing with Elbow Compression Fittings on each end. You need to cut off a piece of the supplied Tubing to create the Return Line.

**Important:** The Return Line uses the same ¼ inch, black, polyethylene Tubing as the Air Lines. Be sure not to confuse the two: the Return Line and the Air Lines do completely different things and **must** be kept separate from each other.

The following drawing shows how to connect the Return Line.

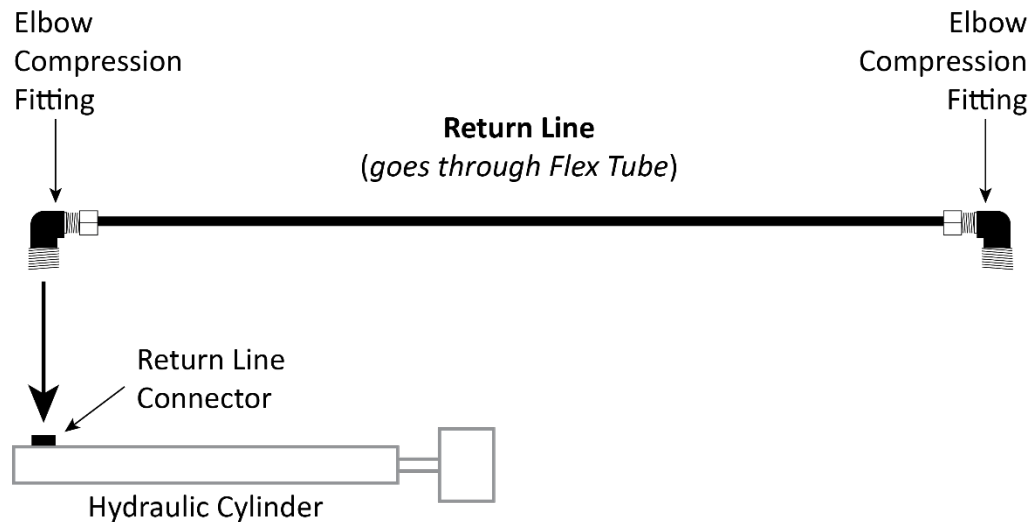

*Drawing not to scale. Some components not shown. Some components exaggerated for clarity.*

### To install the Return Line:

1. Measure the distance from the Return Line connector on the Hydraulic Cylinder to the Return Line connector on the Power Unit.
2. Cut a piece of Tubing to the measured length from the roll of Tubing that comes with the Lift.  
It is better to cut the Tubing a little too long rather than a little too short.
3. Route the Tubing from the Hydraulic Cylinder, through the Retaining Rings on the underside of the Powerside Runway, through the Flex Tube, and out next to where the Power Unit will be installed.  
Route the Return Line through the Retaining Rings so that it is away from the Lifting Cables.
4. Remove the Shipping Plug from the Return Line Connector on the Hydraulic Cylinder.
5. Connect and tighten an Elbow Compression Fitting into the opening where the Shipping Plug was.
6. Connect one end of the Return Line to the Elbow Compression Fitting you just installed.  
Refer to [Working with Compression Fittings and Tubing](#) for instructions.
7. Leave the Power Unit end of the Return Line hanging out of the Flex Tube for now.  
It will be connected to an Elbow Compression Fitting and to the Power Unit later in the installation.

---

## Installing the Power Unit

This section describes how to *install*, but not make the connections to, the Power Unit for your Lift. An Electrician is *not* needed to *install* the Power Unit; however, an Electrician *is* required to *connect* the Power Unit to its power source.

The Power Unit *must* be installed on the Power Post: attach it to one of the two Mounting Brackets, whichever is more convenient for the location.

**Important:** Many people install the Flex Tube Bracket Plate and/or the Zero Angle Bracket at the same time as they install the Power Unit. Read [Installing the Second End of the Flex Tube](#) and [Installing the Pushbutton Air Valve](#) for more information to see if this makes sense for your installation.

 **DANGER** Risk of explosion: The Power Unit has internal arcing or parts that may spark and should not be exposed to flammable vapors. Never expose the Power Unit motor to rain or other damp environments. Damage to the motor caused by water is *not* covered by the warranty.



**Tip** The Power Unit is heavy. BendPak recommends having one person hold the Power Unit while another person bolts it into place.

### To install the Power Unit:

1. Find the four supplied Hex Head Bolts, Flat Washers, Nyloc Nuts, and the Vibration Dampener.
2. Line up the holes on the Vibration Dampener with the four holes in the Mounting Bracket.
3. If you are going to install the Flex Tube Bracket Plate and/or the Zero Angle Bracket at the same time as the Power Unit, now is the time to put them into place.
4. Put a Flat Washer onto each of the four Hex Head Bolts, slide the Bolts through the back of the Mounting Bracket and through the holes in the Vibration Dampener.
5. Have the second person lift the Power Unit and slide the holes in the Back Plate of the Power Unit over the Bolts that are coming out of the Vibration Dampener.
6. Put on the Nyloc Nuts to secure the Power Unit in place.

---

## Filling the Hydraulic Fluid Reservoir

The Hydraulic Fluid reservoir on the Power Unit must be filled with Hydraulic Fluid or automatic transmission fluid before you begin normal operation of the Lift. ***When you receive the Lift, the fluid reservoir is empty.*** The Power Unit will not work correctly until it is filled with approved Hydraulic Fluid.

Approved fluids are any general purpose ISO-32, ISO-46, or ISO-68 hydraulic fluid, approved automatic transmission fluids such as Dexron III, Dexron VI, Mercon V, Mercon LV, or any synthetic multi-Vehicle automatic transmission fluid.

 **WARNING** Do not run your Power Unit without Hydraulic Fluid; you will damage it.

Even though you are not connecting the Power Unit at this point, you can fill the Hydraulic Fluid Reservoir with fluid.

### To fill the Reservoir with Hydraulic Fluid:

1. Remove the Reservoir Cap and set it aside.

Make sure to keep the Reservoir Cap clean; you do not want any contaminants getting into the Hydraulic Fluid Reservoir.

2. Fill the Hydraulic Fluid Reservoir on the Power Unit with the appropriate amount of approved fluids.

The Hydraulic Reservoir holds from 3.5 to 4.5 gallons, depending on your Power Unit:

- **5585280**: 3.7 gallons / 14 liters
- **5585181**: 4.5 gallons / 17 liters
- **5585178**: 3.5 gallons / 13.25 liters
- **5585182**: 4.5 gallons / 17 liters
- **5585247**: 3.7 gallons / 14 liters

Use care to keep the fluid clean when filling the reservoir.

Approved fluids are any general purpose ISO-32, ISO-46, or ISO-68 hydraulic fluid or approved automatic transmission fluids such as Dexron III, Dexron VI, Mercon V, Mercon LV, or any synthetic multi-Vehicle automatic transmission fluid.

***Do not connect the Power Unit to a power source at this point.***

3. Replace the Reservoir Cap.



---

## Installing the Second End of the Flex Tube

Once the Power Unit is installed, you can install the second end of the Flex Tube (the other end was connected to the Powerside Runway earlier in the installation).

The Flex Tube consolidates and protects the lines that come out from under the Powerside Runway: the Air Line, the Return Line, and the Hydraulic Hose.

To install the Flex Tube, you first need to connect the Flex Tube Bracket Plate and the Flex Tube Angle Plate, if you have not yet connected them.

### Flex Tube Bracket Plate

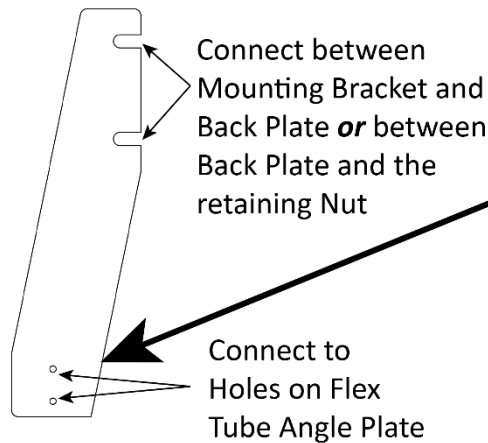

### Flex Tube Angle Plate

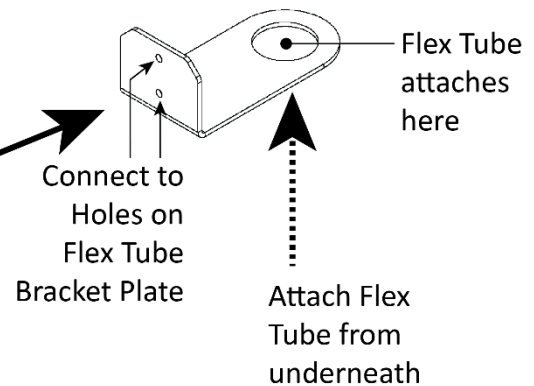

The components involved include:

- **Flex Tube.** Protects the Air Line, the Return Line, and the Hydraulic Hose. One end connects to the hole on the Flex Tube Angle Plate from underneath, the other end connects to the hole on the side of the Powerside Runway.
- **Flex Tube Bracket Plate.** The two notches at the top attach near the Mounting Bracket on the Power Post. The two holes at the bottom connect to the Flex Tube Angle Plate.
- **Flex Tube Angle Plate.** Attaches to the Flex Tube Bracket Plate via two holes, giving you the flexibility to connect it on either side. Includes the hole to which the Flex Tube connects.

BendPak recommends orienting the Flex Tube so that the lines coming out of it are near where they connect on the Power Unit and to the Pushbutton Air Valve.

### To install the Flex Tube:

1. Find the Flex Tube Bracket Plate and the Flex Tube Angle Plate. The Flex Tube is already nearby.
2. Install the Flex Tube Bracket Plate.

Location options are: between the Mounting Bracket and the Back Plate or between the Back Plate and the retaining Nut (see the drawing on the following page).

**Note:** It is common to install the Flex Tube Bracket Plate between the Mounting Bracket and the Back Plate. This allows the Zero Angle Bracket (which holds the Pushbutton Air Valve and is described in the next section) to be installed between the Back Plate and the retaining Nut. This configuration is common, but it is not required.

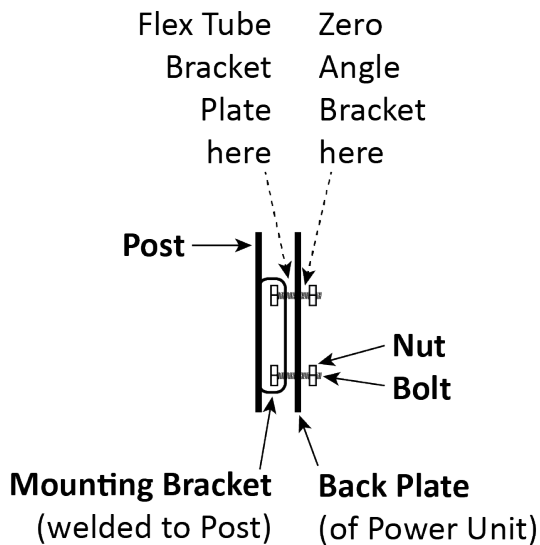

*Drawing not necessarily to scale. Not all components shown. Side view of where the Power Unit attaches to the Power Post. Some aspects exaggerated for clarity. The Zero Angle Bracket is described in the next section.*

3. Connect the Flex Tube Angle Plate to the Flex Tube Bracket Plate so that the hole for the Flex Tube is best positioned for connecting the Return Line, the Air Line, and the Hydraulic Hose.  
The Flex Tube Angle Plate can be connected on either side of the Flex Tube Bracket Plate.
4. When the Flex Tube Angle Plate is in place, unscrew the Plastic Nut from the end of the Flex Tube.
5. Holding the Flex Tube by the Plastic Collar, put the Threads through the hole on the Flex Tube Angle Plate **from underneath**.
6. Screw the Plastic Nut back onto the Threads and tighten.

## Installing the Pushbutton Air Valve

Once the Power Unit and the Flex Tube are installed, you can install the Pushbutton Air Valve, which requires the Zero Angle Bracket (which may already have been installed).

The Pushbutton Air Valve is used to lower the Runways. It can go on either side of the Power Unit, whichever is easier to access for the Lift operator.

Once the pushbutton is in place, you need to connect it to both the Air Line (which is coming out of the Flex Tube) and the customer-supplied air pressure.

An Air Supply (3 to 25 cfm at 50 to 150 psi) is required to disengage the Safety Locks when you want to lower the Lift. Regulate the line to a maximum pressure of 150 psi; the air lines could burst or the Safety Locks malfunction at pressure over 150 psi.

The following drawing shows the Zero Angle Bracket and where it connects.

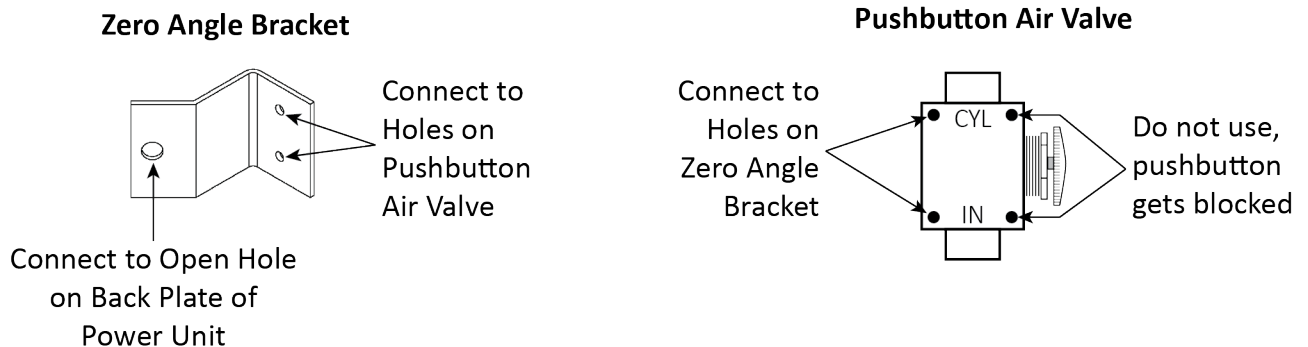

The components involved include:

- **Zero Angle Bracket.** Attaches at the Mounting Bracket on the Power Post or to other available holes on the Back Plate of the Power Unit. Holds the Pushbutton Air Valve, so be sure to orient the Zero Angle Bracket so that the Pushbutton Air Valve can be easily reached by the Lift operator.
- **Pushbutton Air Valve.** Used to lower the Runways.
- **Air Line Compression Elbow Fitting.** Connects the Pushbutton Air Valve to the Air Line coming out of the Flex Tube.
- **Straight Expander Fitting.** Connects the Pushbutton Air Valve to the customer-supplied air pressure.

### To install the Pushbutton Air Valve:

1. Find the necessary components: Zero Angle Bracket, Pushbutton Air Valve, Air Line Compression Elbow Fitting, and Straight Expander Fitting.
2. Connect the Zero Angle Bracket at the desired location (if it has not already been connected).

It can attach to an available hole on the Back Plate of the Power Unit or to one of the Bolts that connect the Power Unit to the Mounting Bracket on the Power Post.

The best location is one that is visible and easily reached by the Lift operator.

3. Connect the Pushbutton Air Valve to the Zero Angle Bracket.

Use the two holes on the Pushbutton Air Valve on the side away from the actual pushbutton. If you use the holes next to the pushbutton, the Zero Angle Bracket interferes with the pushbutton when you try to use it.

The following drawing shows the Pushbutton Air Valve and its connections.

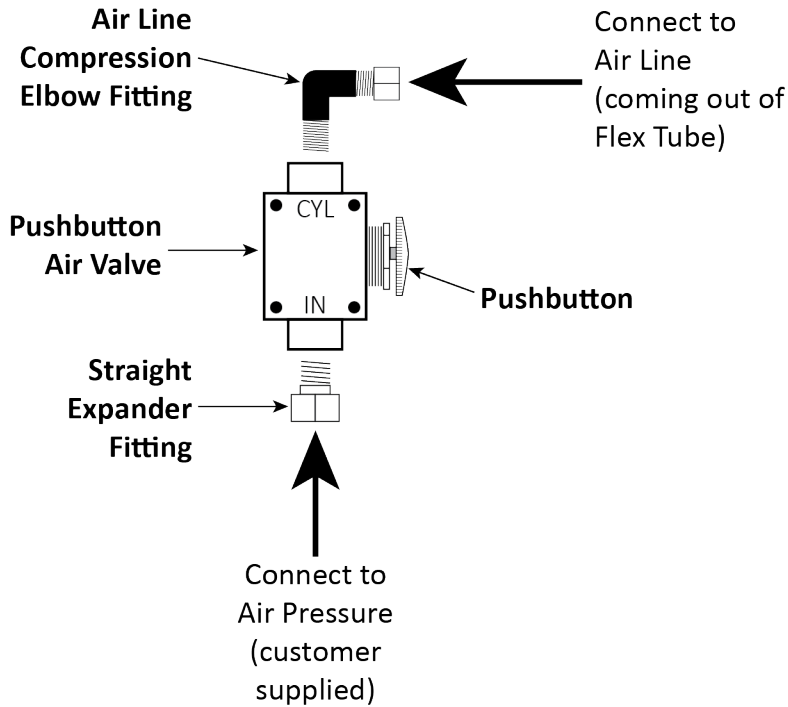

4. Connect the Air Line Compression Elbow Fitting and the Straight Expander Fitting to the appropriate locations on the Pushbutton Air Valve.

The elbow fitting connects to the opening labelled **CYL**. The straight fitting to the opening labelled **IN**. See the drawing above.

5. Attach the Air Line (coming out of the Flex Tube) to the compression fitting on the elbow fitting and the customer-supplied air to the straight fitting.

**Important:** The Return Line also comes out of the Flex Tube and is the same kind of tubing as the Air Line. **Do not attach the Return Line to the Pushbutton Air Valve by mistake.** Double check to make sure you are attaching the Air Line to the Pushbutton Air Valve.

For the customer-supplied air pressure, 3 to 25 cfm at 50 to 150 psi is required.

---

## Connecting the Return Line

The Return Line should already be routed through the Flex Tube and connected to the Return Line Connector on the Hydraulic Cylinder.

This section describes how to connect the other end of the Return Line to the Power Unit.

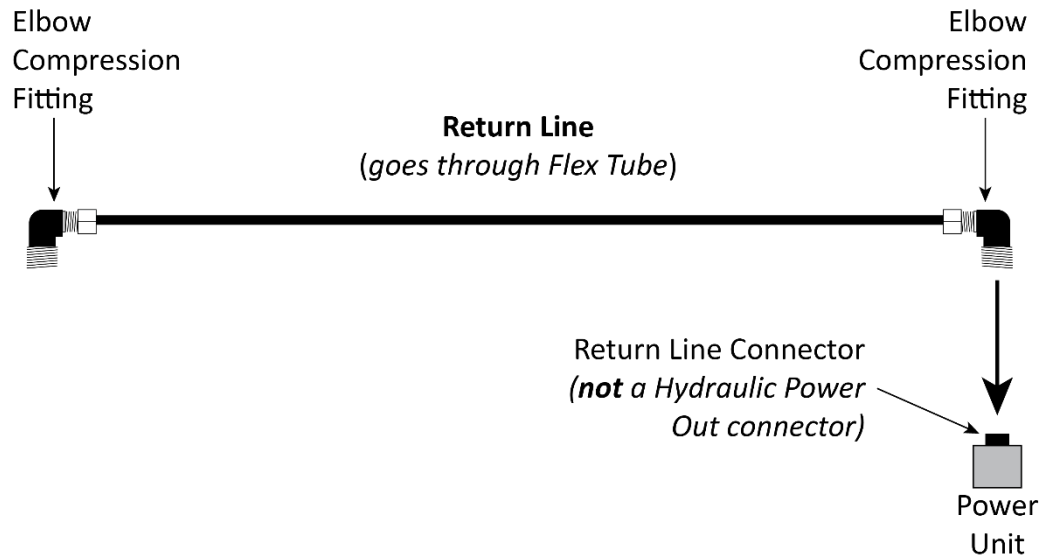

### To attach the Return Line to the Power Unit:

1. Locate the Return Line Connector on the Power Unit and remove the Shipping Plug.  
Refer to the drawing on the next page for the location of the Return Line Connector on your Power Unit.
2. Connect and tighten the threaded end of an Elbow Compression Fitting to the Return Line Connector on the Power Unit.  
For information about connection compression fittings, refer to [Working with Compression Fittings and Tubing](#).
3. Find the Return Line coming out of the Flex Tube and connect it to the other connector on the Elbow Compression Fitting.

**Important:** The Air Line, at one point, was also coming out of the Flex Tube and it uses the same kind of tubing as the Return Line. The Air Line should have been connected in the previous section, but if it was not, make sure you are attaching the Return Line to the Power Unit and not the Air Line. **Do not attach the Air Line to the Power Unit by mistake; it connects to the Pushbutton Air Valve.**

The Hydraulic Out and Return Line ports for HD-7P and HD-7W Power Units are shown below.

Hydraulic Out ports on the Power Units are labeled **P** below, while Return Line ports are labeled **R**. Port labels on individual Power Units may be slightly different or may not be present at all.

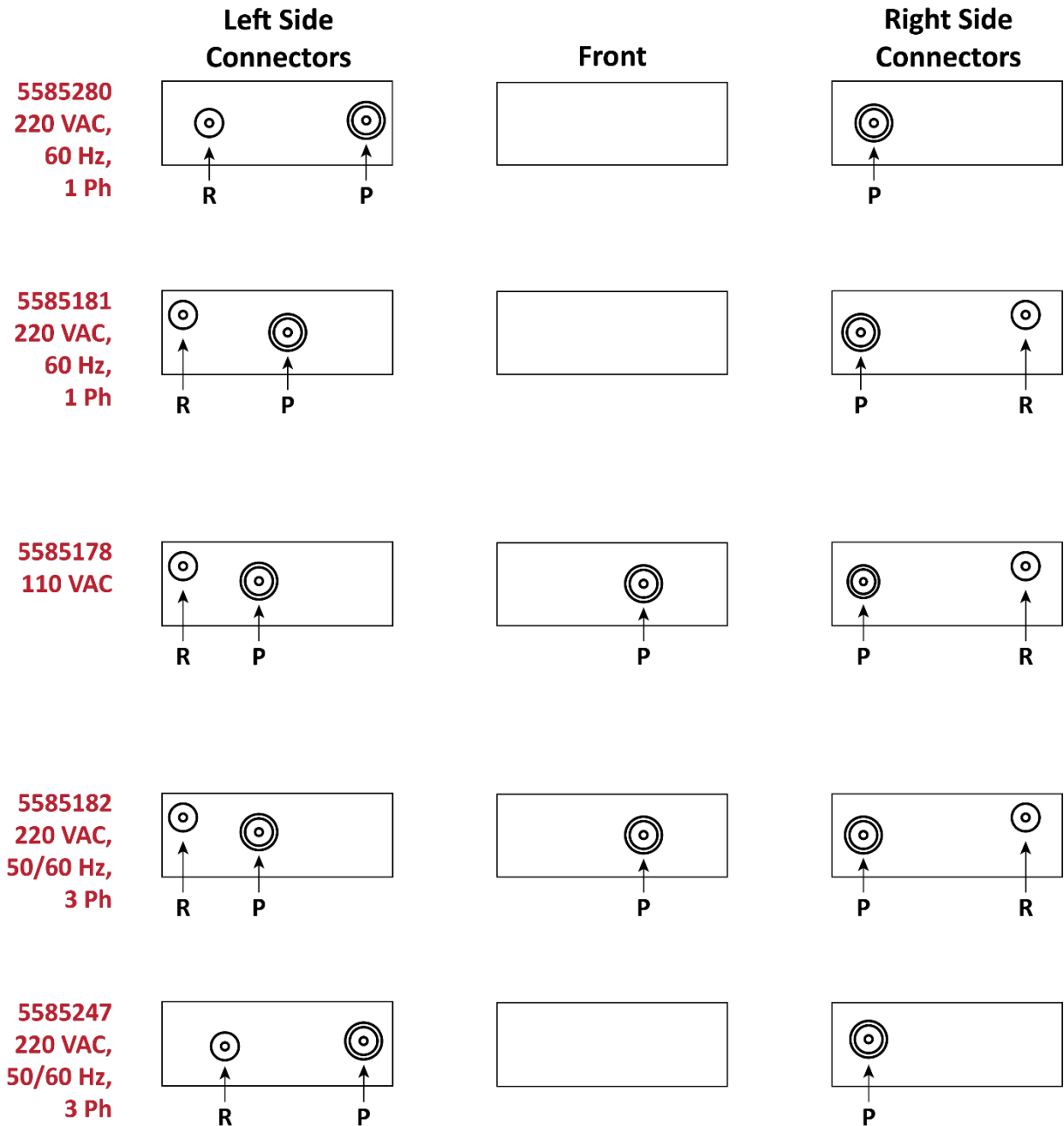

---

## Connecting the Hydraulic Hose

The Hydraulic Hose has two ends:

- **Curved End.** Attaches to a JIC to NPT hydraulic fitting and then to the Hydraulic Connector on the Hydraulic Cylinder. *This connection has already been made.*
- **Straight End.** Attaches to a JIC to ORB hydraulic fitting and then to a Hydraulic Out Connector on the Power Unit. Described in this section.

The following drawing shows how to connect the Straight End of the Hydraulic Hose to a Hydraulic Power Out connector on the Power Unit.

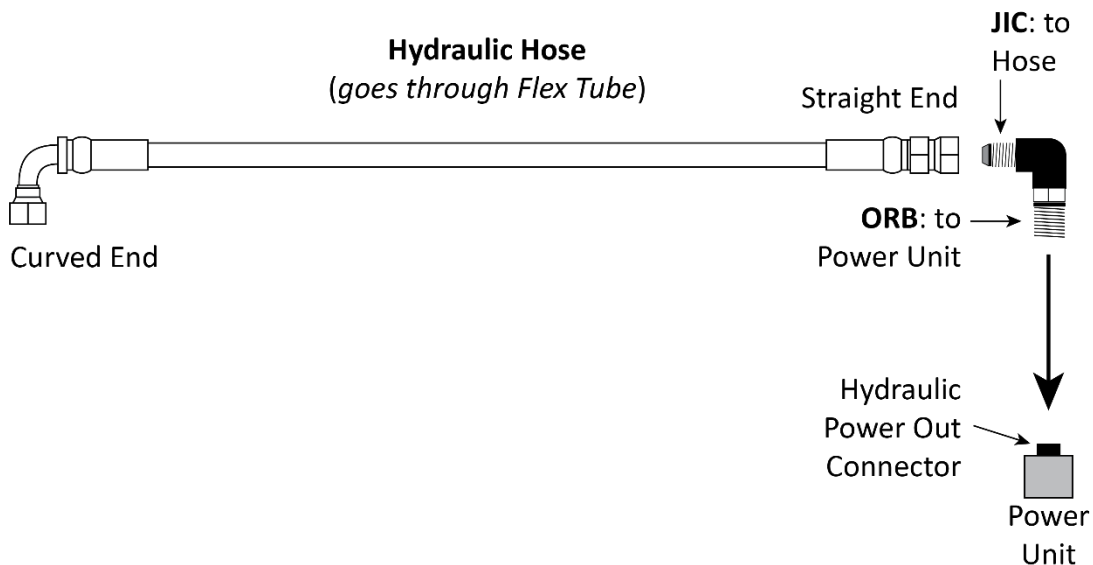

### To connect the Hydraulic Hose to the Power Unit:

1. Find the JIC-to-ORB hydraulic fitting. The Hydraulic Hose is already in place, with the Straight End coming out of the Flex Tube.
2. Locate the Hydraulic Power Out connector on the Power Unit you want to use and remove the Shipping Plug.  
Refer to the drawing on the previous page for the locations of the Hydraulic Power Out connectors on your Power Unit.
3. Connect and securely tighten the ORB Connector on the JIC-to-ORB Fitting to the Hydraulic Power Out connector whose Shipping Plug you just removed.
4. Connect and securely tighten the Hydraulic Hose coming out of the Flex Tube to the JIC Connector of the JIC-to-ORB Fitting.

---

## Contacting the Electrician

As mentioned previously, there are installation tasks that **require** a certified Electrician.

**⚠ DANGER** All wiring **must** be performed by a licensed, certified Electrician.

The Electrician needs to:

- **Connect the Power Unit to an appropriate power source.** A power source is required. Refer to **Connecting to a Power Source** for more information.
- **Install a Power Disconnect Switch.** Ensures you can quickly and completely interrupt electrical power to the Lift in the event of an electrical circuit fault, emergency situation, or when equipment is undergoing service or maintenance. You must put it within sight and easy reach of the Lift operator. Refer to **Install a Power Disconnect Switch** for more information.
- **Install a Thermal Disconnect Switch.** Ensures the equipment shuts down in the event of an overload or an overheated motor. Refer to **Install a Thermal Disconnect Switch** for more information. Note that the Power Unit that comes with the Lift is **not** thermally protected.

The electrician is responsible for providing:

- an appropriate cable and plug to attach to the Power Unit, for connection to a wall outlet **or** an appropriate cable that attaches the Power Unit to the facility's electrical system
- a Power Disconnect Switch
- a Thermal Disconnect Switch

Refer to **Wiring Diagrams** for wiring information for your Lift's Power Unit.

Additional information is supplied in the sections describing these tasks.



---

## Connecting to a Power Source

The Power Unit must be connected to an appropriate power source.

**⚠ DANGER** All wiring **must** be performed by a licensed, certified Electrician. Do not perform any maintenance or installation on the Lift without first making sure that main electrical power has been disconnected from the Lift and cannot be re-energized until all procedures are complete. The Lift uses electrical energy; if your organization has Lockout/Tagout policies, make sure to implement them after connecting to a power source.

**Important:** Make clear to your Electrician that all electrical work **must** conform to applicable local, state, and federal codes, rules, and regulations, such as state and federal OSHA regulations and electrical codes.

Your Lift was ordered with one of the following Power Units:

- **220 VAC, 60 Hz, 1 Phase.** 220 VAC, for North American countries (U.S., Mexico, Canada). Could be Power Unit 5585280 or 5585181.
- **110 VAC.** 110 VAC, for North American countries (U.S., Mexico, Canada). Should be Power Unit 5585178.
- **220 VAC, 50/60 Hz, 1 Phase.** 220 VAC, for countries *outside* North America. Could be Power Unit 5585182 or 5585247.

Power Units are provided by different vendors so there may be minor differences in look and feel. However, all Power Units of the same type provide the same level of functionality.

All Power Units come with a ‘pigtail’ coming out of the Electrical Box. To connect your Power Unit to a power source, remove the pigtail and connect the Electrical Box to the electrical system at your location or to an appropriate power cord with plug.

Make clear to your Electrician that all electrical work **must** conform to applicable local, state and federal codes, rules, and regulations, such as state and federal OSHA regulations and electrical codes.

**⚠ DANGER** The following procedure **must** only be performed by a licensed, certified Electrician.

### To connect the Lift to a power source:

1. Locate the Pigtail coming out of the Electrical Box on the Power Unit.
2. Open the Electrical Box, **remove the Pigtail**, and then either:
  - Wire the Power Unit directly into the facility’s electrical system.
  - Wire a power cord with appropriate plug *inside the Electrical box* where the Pigtail was wired.

Wiring information is either on the outside of the Power Unit under the Electrical Box or inside the cover of the Electrical Box. Have the Electrician use that wiring information to wire the Power Unit to the power source.

You can also find the Wiring Diagram for your Power Unit in [Wiring Diagrams](#).

3. Close the Electrical Box.

## Installing a Power Disconnect Switch

**⚠ WARNING** A main Power Disconnect Switch is **not** provided with this equipment.

A Power Disconnect Switch is a National Electrical Code (NEC) requirement. They are designed to interrupt electrical power in the event of an electrical circuit fault, emergency situation, or when equipment is undergoing service or maintenance.

BendPak strongly recommends that you install a Power Disconnect Switch that is properly rated for the incoming power.

**⚠ DANGER** All wiring **must** be performed by a licensed, certified Electrician.

Your Power Disconnect Switch must be readily accessible and installed so that it is in easy reach of the Lift operator. It must be clearly and legibly marked to indicate its purpose.

The drawing to the right shows a toggle Power Disconnect Switch between the Lift's power source and its Power Unit. A quick flip of the switch immediately cuts power to the Lift.

Make sure to have a licensed, certified Electrician install the Power Disconnect Switch.

Make sure the Electrician selects a UL-listed Power Disconnect Switch.

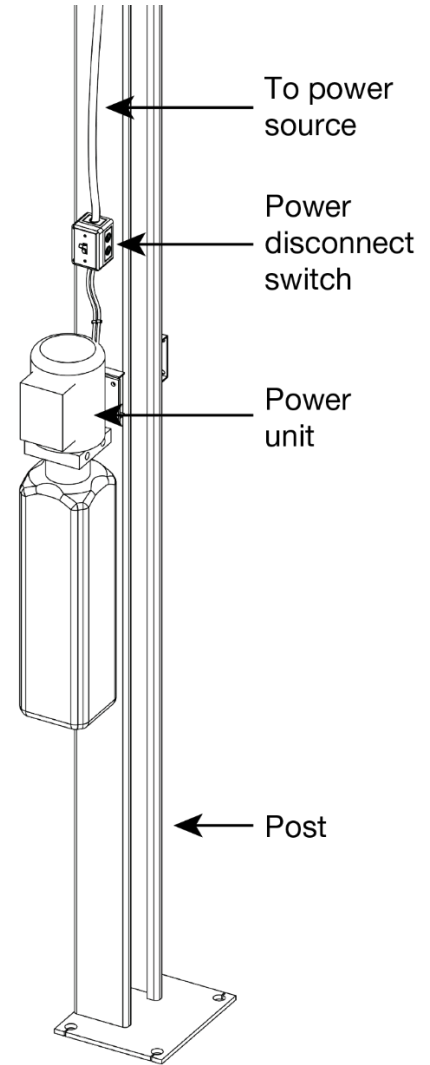

## Installing a Thermal Disconnect Switch

**⚠ WARNING** The Lift's motor does **not** have thermal overload protection.

Connect a motor Thermal Disconnect Switch or overload device that will make sure the equipment shuts down in the event of an overload or an overheated motor.

**⚠ DANGER** All wiring **must** be performed by a licensed, certified Electrician.

High running amps that exceed the motor's full load amps (FLA) rating may result in permanent damage to the motor.

BendPak strongly recommends you **not** exceed the rated duty cycle of the Lift's motor.

## About Effective Embedment

Anchor Bolts (also called Wedge Anchors) get their holding strength from how far down into the Hole the Anchor Bolt's Expansion Sleeve presses into the Concrete (called Effective Embedment) and how forcefully the Expansion Sleeve presses into the Concrete (based on the width of the hole and how much Torque is applied).

The further down into the Hole you get the Expansion Sleeve, the greater the Effective Embedment and thus the greater the holding strength of the Anchor Bolt. The hole should be drilled the same width as the Anchor Bolt with no wobbling. The correct amount of Torque is a range; too little Torque and the Anchor Bolts hold with less strength, too much Torque and you could damage the Concrete and lessen the Anchor Bolt's holding strength.

**Note:** Some people confuse Effective Embedment with *Nominal* Embedment, which is how far down into the Hole the *bottom* of the Anchor Bolt is. The two are **not** the same; Nominal Embedment does not tell you anything about the holding strength of the Anchor Bolt.

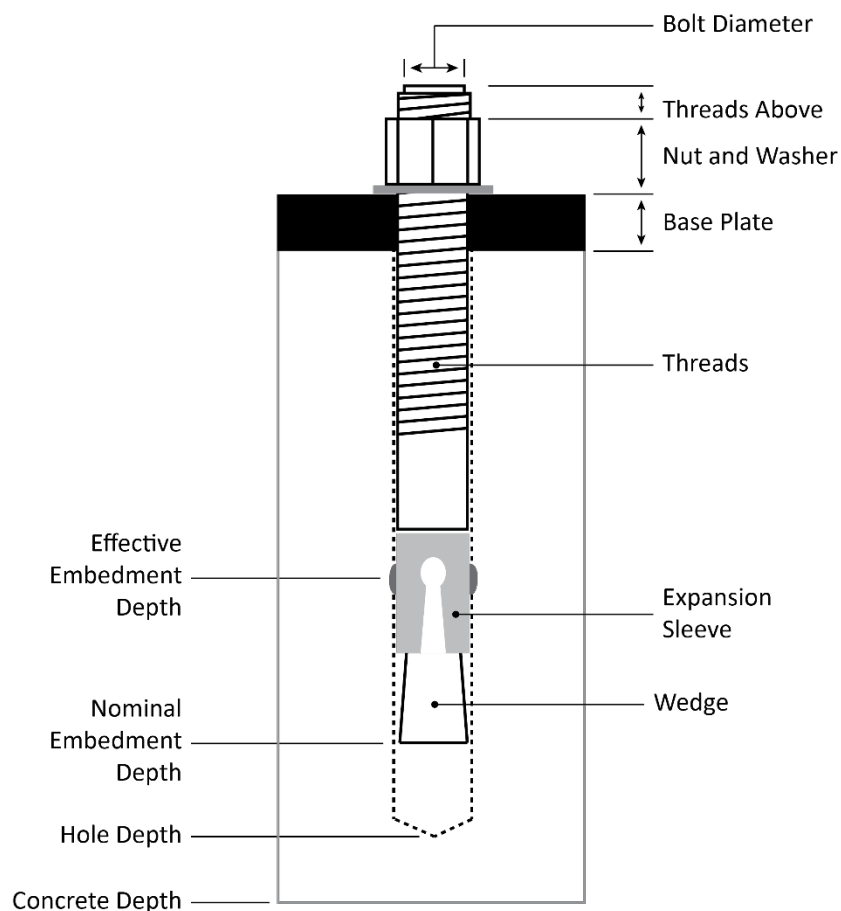

Make sure to carefully follow the specifications and instructions in [Anchoring the Posts](#).

**⚠ WARNING** Use only the Anchor Bolts that came with your Lift. Only install your Lift on a Concrete floor. Make sure to get the correct amount of Effective Embedment and use the correct amount of Torque.

---

## Anchoring the Posts

If you are going to, but have not done so already, you need to anchor the Lift's four Posts. Install one Anchor Bolt in each corner of each Base Plate, 16 Anchor Bolts total. Anchoring is optional.

Concrete specifications are:

- **Depth:** 4.25 in (108 mm) thick
- **PSI:** 3,000 PSI, minimum
- **Cured:** 28 days, minimum

Anchor Bolt specifications are:

- **Length:** 4.75 in (120.5 mm)
- **Diameter:** .75 in (19 mm)
- **Anchor Torque:** 85 – 95 pound feet (do *not* Torque less than 80 or more than 105)

**⚠ WARNING** Your Concrete and Anchor Bolts **must** meet these specifications. Only install your Lift on a Concrete surface. If you install a Lift on asphalt or any other surface, or your Concrete or Anchor Bolts do not meet these specifications, it could lead to product damage, Vehicle damage, personal injury, or even loss of life.

BendPak Lifts are supplied with installation instructions and Concrete fasteners meeting the criteria as prescribed by the current version of the American National Standard “Automotive Lifts – Safety Requirements for Construction, Testing, and Validation” ANSI/ALI ALCTV.

**⚠ WARNING** Use only the Anchor Bolts that came with your Lift. If you use components from a different source, you void your warranty and compromise the safety of everyone who installs or operates the Lift.

Lift buyers are responsible for conforming to all regional, structural, and seismic anchoring requirements specified by any other agencies and/or codes, such as the Uniform Building Code and/or International Building Code.

### To anchor the Posts:

1. Locate the hardware you will need: four Anchor Bolts, four Nuts, and four washers **per Post**.
2. Using the Base Plates as guides, drill the holes for the Anchor Bolts—one hole in each corner of the Base Plate, so four holes total per Base Plate.

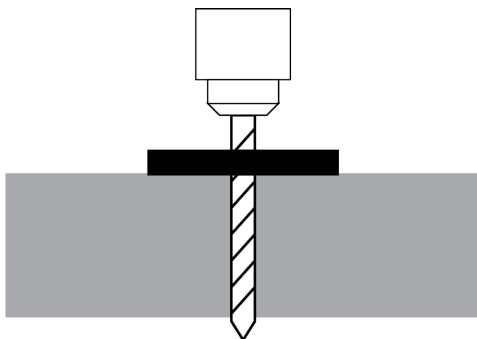

Go in straight, in the center of the hole; do not let the drill wobble.

Use a carbide bit (conforming to ANSI B212.15).

The diameter of the drill bit must be the same as the diameter of the Anchor Bolt. So if you are using a ¾ inch diameter Anchor Bolt, for example, use a ¾ inch diameter drill bit.

3. Vacuum each hole clean.

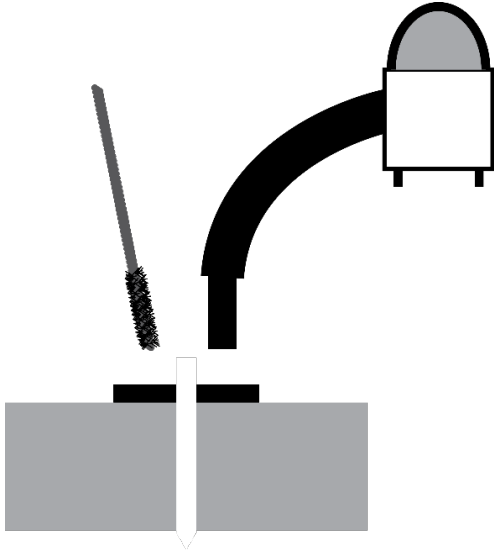

BendPak recommends using a vacuum to get the hole very clean. You can also use a wire brush, hand pump, or compressed air; just **make sure to thoroughly clean each hole**.

Do **not** ream the hole. Do **not** make the hole any wider than the drill bit made it.

- Important:** The holding strength of an Anchor Bolt is partly based on the how cleanly the Expansion Sleeve presses against the Concrete. If the hole is dirty, the Expansion Sleeve does not press as cleanly. If the hole is too wide, the Expansion Sleeve does not press with as much force. Both result in less holding strength.

4. Plumb each Post; install any needed Shims.

Use a Transit Level to estimate the Shim requirements: use a target to find the difference in height between the Posts. The difference is the estimated amount of Shim thickness you will need.

Do not shim a Post more than half an inch using the provided Shims. A maximum of 2 inches is possible by ordering optional Shim Plates. Contact BendPak at **(800) 253-2363**, extension 191 to order. Please have the model and serial number of your Lift available.

Take your time while plumbing and shimming the Posts; **your goal is to make the Lift as level as possible**.

5. Make sure the Washer and Nut are in place, **with the top of the Nut flush with the top of the Anchor Bolt**, then insert the Anchor Bolt into the hole.

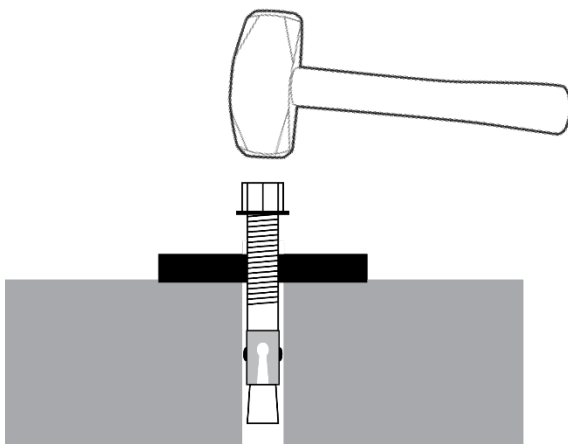

- 
6. Hammer or mallet the Anchor Bolt down into the hole.

The Expansion Sleeve of the Anchor Bolt may prevent the Anchor Bolt from passing through the hole in the Base Plate too far; this is normal. The hammer or mallet will get the Expansion Sleeve through the Base Plate and part of the way down into the hole.

Even using a hammer or mallet, the Anchor Bolt should only go into the hole *part* of the way; this is normal. If the Anchor Bolt goes **all** the way in with little or no resistance, the hole is too wide.

Once past the hole in the Base Plate, the Anchor Bolt eventually stops going down into the hole as the Expansion Sleeve contacts the sides of the hole; this is normal.

7. Hammer or mallet the Anchor Bolt the rest of the way down into the hole.

**Stop when the Washer is snug against the Base Plate.**

8. Torque each Nut **clockwise** to the recommended installation torque, 85 – 95 pound feet, using a Torque Wrench.

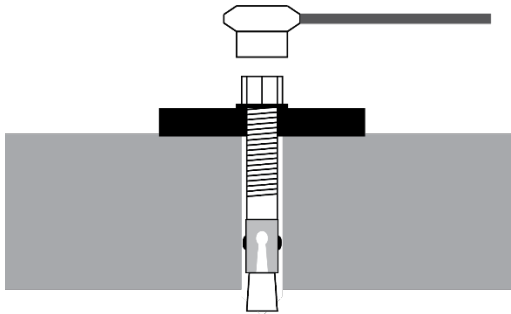

**Important:** Do **not** use an impact wrench to torque the Anchor Bolts.

Do not torque past 105 pound feet; you could damage the Concrete.

Torquing the Nut forces the Wedge up, forcing out the Expansion Sleeve and pressing it tightly against the Concrete, which gives you the holding strength you need.

---

## Final Leveling

It is very important that the Lift's Runways are level, or as close to level as possible. The following procedure describes how to fine tune how level your Lift is.

The goal is that the four Safety Locks on the Lift engage at the same time.

### **To do final leveling on the Lift:**

1. Raise your Lift to the first Safety Lock position (the Primary Safety Locks, not the Slack Safety Locks).
2. Use a transit level or other leveling mechanism to evaluate how level the Posts and Runways are to each other.
3. If you need to adjust a Runway, use the Top Nut and Stop Nut on the Top Cap of each Post to make adjustments to the Ladder in that Post (which impacts the levelness of the Runway and when the Safety Locks engage).
4. Raise the Lift to full height, listening as the Safety Locks engage.  
If you hear the Safety Locks engaging at the same time, no further adjustments are necessary.  
If the Safety Locks are not engaging at the same time, check the leveling, make necessary adjustments, and then raise the Lift again and listen as the Safety Locks engage.
5. When you are satisfied the Lift is level, firmly secure the Nuts at the top of each Post.

---

## Installing Accessories

The accessories available for your Lift include:

- **Tire Stops.** Installed at the Front of the Lift. Hold the Tires of the Vehicle in position. BendPak recommends chocking the rear Tires, so that the Vehicle stays in place. Included with the Lift.
- **Ramps.** Installed at the Rear of the Lift. Allow Vehicles to be easily driven onto the Runways. Included with the Lift.
- **Caster Kit.** Gets your Lift up off the ground so you can move it. Optional.

Other optional accessories include Aluminum Ramps, Aluminum Decks, and a Rolling Oil Drain Pan. All are shown near the bottom of the [HD-7P or HD-7W product page](#).

### ***Tire Stops***

Tire Stops are attached on the Front of the Lift. They prevent the tires of the Vehicle on the Lift from going too far forward.

#### **To install the Tire Stops:**

1. Locate the two Tire Stops, two Tire Stop Pins, and four Rotor Clips.
2. Put one Tire Stop in position between the Tubes attached to the Runway, then put the Tire Stop Pin all the way through the Tire Stop and the Tubes.
3. Secure the Tire Stop with Rotor Clips on each end of the Tire Stop Pin.
4. Repeat Steps 2 and 3 for the second Tire Stop.

### ***Ramps***

Your Lift comes with two steel Ramps, for driving Vehicles onto the Runways.

#### **To install the Ramps:**

1. Find the required components: two Ramps, two Ramp Pins, and four Rotor Clips.
2. Put a Ramp into position on the end of a Runway at the Rear of the Lift, with the Tube on the bottom of the Ramp between the two Tubes on the end of the Runway.
3. Slide a Ramp Pin through the three Tubes, then install Rotor Clips on both ends of the Ramp Pin.

**Note:** The Ramps are awkward, so you may want to consider having two people install them; one to hold the Ramp, the other to put the components into place.

4. Repeat Steps 2 and 3 for the other Ramp.



## Caster Kit

The Caster Kit includes four assemblies, each of which goes under one of the Lift's four Posts. When the Lift is raised by the Caster Kit assemblies, you can move it to the desired location.

**Important:** Only put the Caster Kit assemblies into position to move the Lift. When you are done moving the Lift, remove the Caster Kit assemblies.

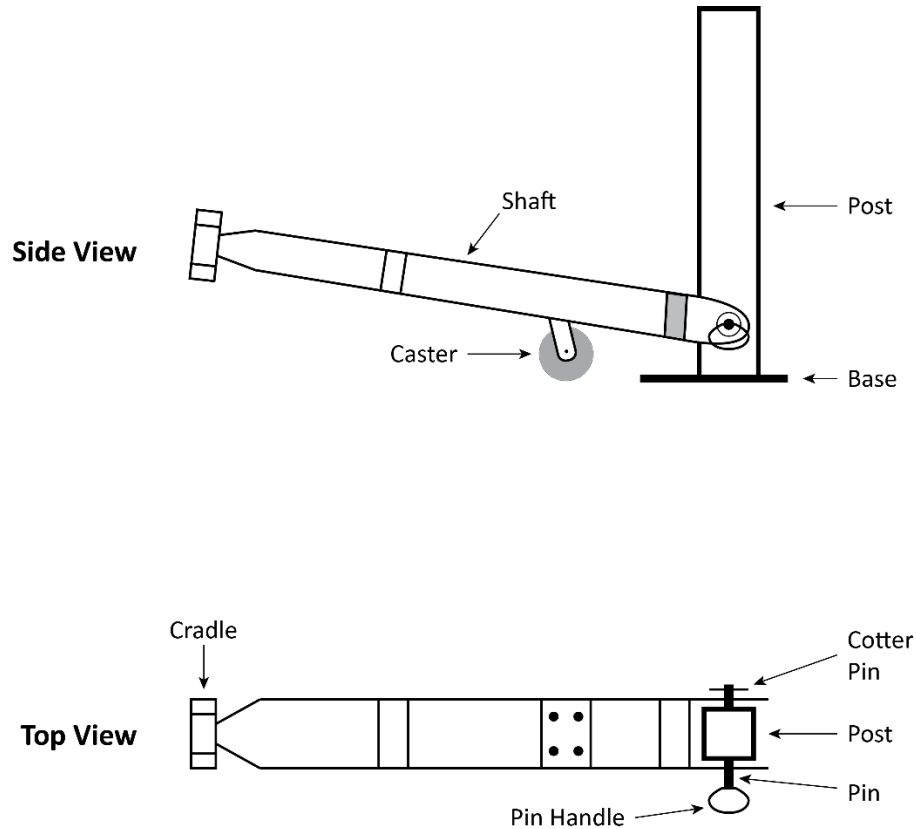

### To move your Lift with the Caster Kit:

1. Raise the Lift to the first Safety Lock and engage it there.
2. Locate the components of the four Caster Kit assemblies.
3. Using the supplied hardware, bolt the four Casters to the four holes in the four Caster Kit Shafts.
4. Take one Shaft and put the open end around the Post, with the Shaft on the inside of the Lift.  
The Cradle of the Shaft needs to be directly below the Crosstube.
5. Put the Pin through the holes in the Caster Kit assembly and the Post.
6. Put the Cotter Pin into place on the end of the Pin.
7. Repeat Steps 4 through 6 for the other three Caster Kit Assemblies.
8. Lower the Lift down to the ground.  
Make sure the Crosstubes are going into all four Cradles on all four Caster Kit Shafts; this is what pushes the Bases of the Posts off the ground so that you can move it.
9. Move the Lift to the desired location.
10. Raise the Lift to a locking position and engage it there.
11. Take off all four Caster Kit assemblies.

---

## Lubricating the Lift

There are six lubrication points on the Lift. All of them are where Sheaves are located:

- **Four lubrication points on the Crosstube Gussets.** One on the outside of each Crosstube Gusset, for a total of four. All four are 15.6 mm (.61") straight grease fittings.
- **Two under the Stacked Sheaves.** One under the Sheaves (under the Powerside Runway at the Rear of the Lift) and another under the Sheaves (under the Powerside Runway at the Front of the Lift).

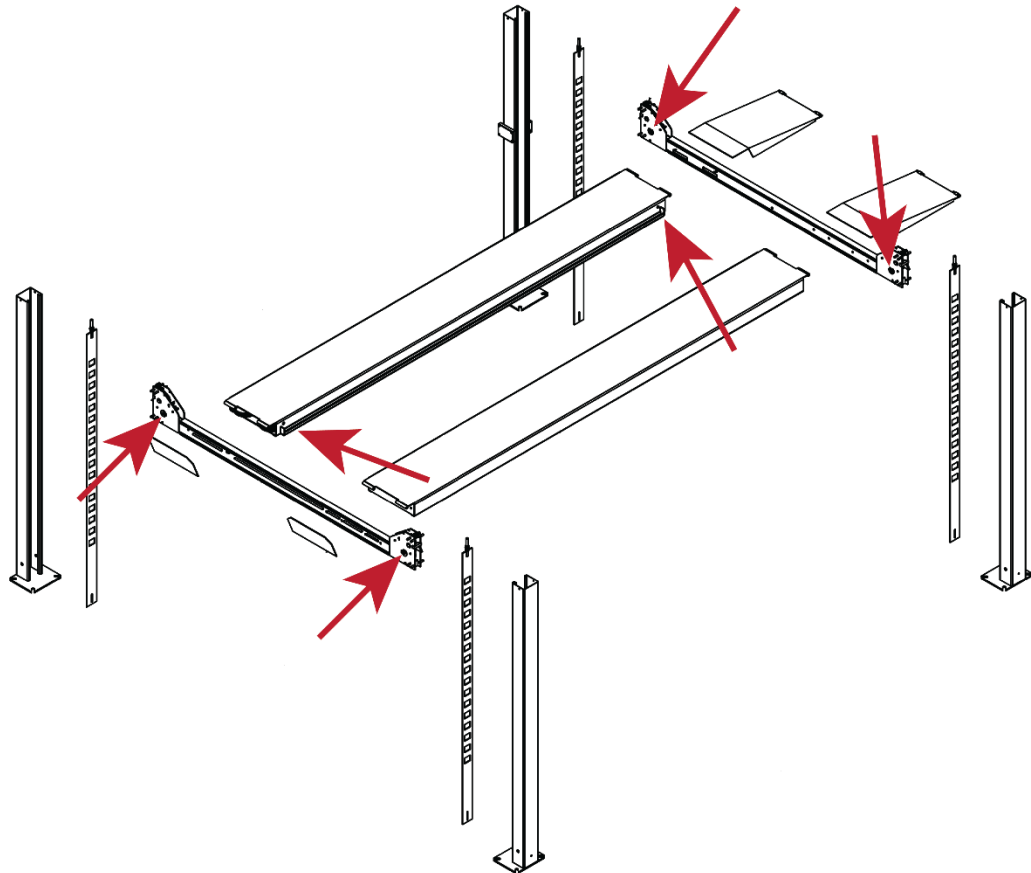

Put a small amount of white lithium grease or similar on each lubrication point before you use the Lift and monthly after putting the Lift into service.

---

## Performing an Operational Test

BendPak strongly recommends doing an Operational Test of your Lift with a typical Vehicle before starting normal service (a typical Vehicle is not required, but is recommended).

**⚠ DANGER** When you even hear the words “automotive lift,” your brain should automatically remember that lifting a Vehicle is a serious endeavor with life-threatening risks. Focus on what you are doing. Automotive Lifts are dangerous tools when used by inexperienced or impaired operators. ***Do not assume you are going to be safe this time because nothing happened last time.***

During the Operational Test, watch the Lift and its components and check for proper installation and operation. If you run into an issue that does not go away, refer to **Troubleshooting** for more information.

**Note:** Residual air in the Hydraulic System can cause the Lift to shake, move erratically, or squeak when you start using it; this is normal. If it happens, do not worry; it will go away as the Hydraulic System is self-bleeding. If it does not go away soon, try bleeding the Cylinder of air. If it still does not go away, refer to **Troubleshooting** for additional information.

### To test your Lift:

1. Check the area around, above, and under the Lift for obstructions; move them if you find any.
2. Drive the Vehicle onto the Lift. Try to center the Vehicle’s tires in the middle of each Runway.  
Put the Vehicle into park, put on the parking brake, put it in gear if it is a manual transmission, and chock the wheels.
3. Press and hold the Up button.  
Both Runways start rising.
4. After the Runways pass one or two Safety Locks (you will hear them as they pass), release the Up button.  
The Runways stop rising.
5. Press **and hold** the Pushbutton on the Pushbutton Air Valve, then press **and hold** the Lowering Handle.  
The Runways start lowering.
6. When the Runways get to the ground, release the Pushbutton and the Lowering Handle.
7. Wait for one minute.

**⚠ CAUTION** Always take a break between cycles. The Power Unit’s motor is **not** constant duty; it cannot be run continuously.

8. Repeat the process, this time raising the Runways to a higher Safety Lock.
9. If the Lift is working without shaking, moving erratically, or squeaking, there is no need to repeat the procedure.

If the Lift is shaking, moving erratically, or squeaking (which is normal during the start-up period), repeat the procedure a couple more times, with at least a one-minute break between cycles.

If you continue to have issues, refer to **Troubleshooting** for assistance.

---

## Reviewing the Final Checklist

Make sure these things have been done **before** putting the Lift into service:

- Review the **Installation Checklist** to make sure all steps have been performed.
- Make sure the Power Unit is getting power from the power source.
- Check the Hydraulic Fluid reservoir on the Power Unit; it must be full of approved Hydraulic Fluid or automatic transmission fluid. **You can damage the motor by running it without enough fluid.**
- Check the Hydraulic System for leaks.
- Make sure all four Posts are properly anchored, shimmed, level, and stable.
- Make sure all Lifting Cables are properly seated in their Sheaves.
- Make sure all Safety Locks are operating normally.
- Make sure the backup Slack Safety Locks are **not** engaged.
- If it has not been done already, perform an Operational Test of the Lift with a typical Vehicle. Refer to **Performing an Operational Test**.
- Make sure a copy of the *Installation and Operation Manual* is left with the Lift.

---

# Operation

This section describes how to operate your automotive Lift.

**⚠ DANGER** When you even hear the words “automotive lift,” your brain should automatically remember that lifting a Vehicle is a serious endeavor with life-threatening risks. Focus on what you are doing. Automotive Lifts are dangerous tools when used by inexperienced or impaired operators. ***Do not assume you are going to be safe this time because nothing happened last time.***

## Safety Considerations

**⚠ WARNING** Your safety is dependent on reading, understanding, and implementing these Safety Rules. ***Do not skip over them—read them carefully and follow them; your life could literally depend on it!***

Do the following ***before*** you raise a Vehicle on your Lift ***every time***:

- **Check the Lift.** Walk all the way around the Lift, checking for any missing, heavily worn, or damaged parts. Do not operate the Lift if you find any issues; instead, take it out of service, then contact your dealer, email [techsupport@bendpak.com](mailto:techsupport@bendpak.com), or call **(800) 253-2363**.
- **Check the area.** Keep the area around and under the Lift clean and free of obstructions; anything that could cause a problem. Do not forget to check ***above*** the Lift. If you find an obstruction, move it out of the way. If you find any other issues, resolve them before using the Lift. ***Do not allow any people or animals within 30 feet of the Lift while it is moving.***
- **Check the operators.** Make sure everyone who is going to operate the Lift has been trained in its use, has read the labels on the unit, and has read the manual. Only the operator at the Controls should be within 30 feet of the Lift while it is moving.

Do not allow children to operate the Lift. Do not allow anyone under the influence of drugs, alcohol, or medication to operate the Lift. Do not allow any unauthorized personnel to operate the Lift.

Operators should wear non-skid, steel toe footwear and safety glasses when operating the Lift.

- **Check for safety.** Make sure everyone who is going to be walking near the Lift is aware of its presence and takes appropriate safety measures. Only put Vehicles on the Runways.

When raising a Vehicle, do not leave it until it is engaged on Safety Locks. When lowering the Lift, do not leave it until it is on the ground.

- **Check the Vehicle.** Never exceed the Lift’s weight rating. Do not allow people inside a Vehicle you are going to raise. Make sure the Vehicle is not overbalanced on either end or either side.

## Using the Controls

The Controls for the Lift include:

- **Up button.** Press and hold to raise the Runways. Located near the top of the Power Unit.

**To put Runways onto a Safety Lock position.** Raise the Runways a little above where you want them, then press and hold the Lowering Handle to back the Runways down onto the Safety Locks (*do not* press and hold the pushbutton on the Pushbutton Air Valve). When the Runways stop going down, they are engaged on a Safety Lock.

*Before leaving the Lift, make sure all four corners are engaged on Safety Locks at the same height.*

- **Lowering Handle.** Press and hold to lower the Runways. Located in the middle of the Power Unit, the Lowering Handle is long and has a ball at the end.

**To lower raised Runways down to the ground: press and hold** the pushbutton on the Pushbutton Air Valve first, then **press and hold** the Lowering Handle.

*Watch the Runways as they go down to make sure they are coming down evenly. If they are not, stop lowering the Lift and troubleshoot the problem.*

**⚠ WARNING** Only leave your Lift either engaged on Safety Locks or fully lowered.

- **Pushbutton Air Valve.** Press and hold as part of the process to lower the Runways. Located on one side or the other of the Power Unit (depending on where it was installed). Pressing and holding the pushbutton on the Pushbutton Air Valve disengages the Safety Locks, which is needed to lower the Runways.

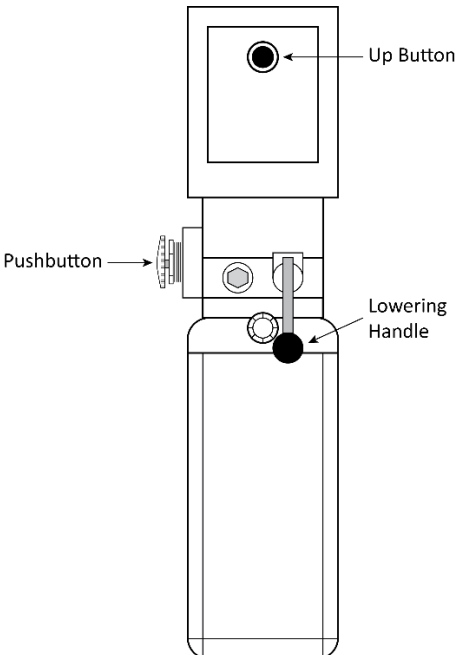
<p><b>To raise Runways and engage them on Safety Locks:</b></p> <ol style="list-style-type: none"><li>1. Press and hold Up Button.</li><li>2. When just past desired height, release Up Button.</li><li>3. Press and hold Lowering Handle.</li><li>4. Runways stop going down when engaged on Safety Locks; release Lowering Handle when they stop.</li></ol> <p><b>Do not press and hold Pushbutton.</b></p> <ol style="list-style-type: none"><li>5. Make sure all four Posts are engaged at same height.</li></ol>	 <p>The diagram shows a vertical control panel. At the top is a square panel with a circular 'Up Button'. Below this is a 'Pushbutton' on the left side. In the center is a vertical 'Lowering Handle' with a ball at the bottom. Labels with arrows point to each of these components.</p>	<p><b>To lower Runways:</b></p> <ol style="list-style-type: none"><li>1. Press and hold Up Button for a couple of seconds; this moves Lift off Safety Locks.</li><li>2. Press and <b>hold</b> Pushbutton.</li><li>3. Press and <b>hold</b> Lowering Handle. Runways begin lowering.</li><li>4. When Runways are fully lowered (on ground), release Pushbutton and Lowering Handle.</li></ol>
---	---	--

---

## Raising and Lowering Vehicles

Keep the following in mind when operating your Lift:

- **Be safe.** Make sure to check for people, pets, and objects that might be in the path of the Lift as you raise or lower it. If there is something in the way, stop the Lift and move it out of the way. Watch the Lift carefully as it raises and lowers.

 **DANGER** Pay careful attention when you are raising or lowering your Lift. If a person or pet gets stuck under the Lift, they could be injured or, in rare cases, killed. If a problem arises, either stop the Lift or get it back to the ground, whichever is safest.

- **The Power Disconnect Switch is there for a reason.** We hope you never have to use it, but if something unexpected happens, use the **Power Disconnect Switch** to immediately stop the Lift from moving.
- **Get what you need out of the Vehicle before lifting it.** It is annoying to raise a Vehicle and then realize you left something inside. ***Never raise your Lift with people or animals in the Vehicle.***
- **Make sure the Vehicle is balanced.** If there is extra weight on one end or the other, remove it or balance it before raising the Vehicle.
- **Center the Vehicle's wheels on the Runway.** Centered wheels keep the Vehicle balanced.

### To raise a Vehicle:

1. Make sure the Runways are on the ground. If they are not, move them down to the ground.
2. Drive a Vehicle onto the Runways.

Make sure all four wheels are fully on the Runways, as close to the center of the Runways as possible.

Put the Vehicle into park and put on the parking brake. If it is a manual transmission, make sure it is in a gear, not in neutral.

Chock the tires.

3. Press the Up button on the Power Unit.

The Runways begin to rise.

4. When the Runways get to the desired height, go up a little bit more, then release the Up button and press and hold the Lowering Handle.

The Runways engage on the most recently passed Safety Locks.

How do you know if one of the four Safety Locks has, for some reason, not engaged? If this happens, the non-engaged corner of the Lift will continue to go down, while the others stay where they are. This results in a Runway that is not flat.

Always check to ***make sure that all four Safety Locks are engaged at the same height*** before working under or near a raised vehicle.

 **WARNING** Only leave your Lift either engaged on Safety Locks or fully lowered.

5. With the Runways engaged on the Safety Locks, check around the Vehicle to make sure everything looks good.

If you see anything wrong, fix it before anyone gets near the Runways or goes under them.

---

**To lower a Vehicle:**

1. Make sure there are no obstructions under the Runways you are about to lower.  
If there are, move them out of the way before lowering the Runways.
2. Press and hold the Up Button for a couple of seconds.  
This moves the Lift off the Safety Locks on which it was engaged.
3. Press and hold the Pushbutton on the Pushbutton Air Valve, then press and hold the Lowering Handle.  
The Runways start lowering.
4. When the Runways are fully lowered (on the ground), release the Pushbutton and the Lowering Handle.
5. Remove the tire chocks.
6. Drive the Vehicle off the Runways.



---

# Maintenance

 **DANGER** Before performing maintenance on your Lift, make sure it is disconnected from power. The Lift uses electrical energy; if your organization has Lockout/Tagout policies, make sure to implement them before performing any maintenance. If you come into contact with high voltage/current, you could be injured or killed.

## To maintain your Lift:

- **Daily:** Keep the Lift clean. Wipe up any spills, clean any dirt.
- **Daily:** Make a visual inspection of all moving parts and check for damage or excessive wear. Replace any damaged or worn parts before using the Lift.

 **DANGER** Do not use the Lift if the Lifting Cables are damaged or extremely worn. If a Vehicle is raised when you notice the damage or extreme wear, very carefully lower the Vehicle to the ground. When the Lift is on the ground, take it out of service, disconnect it from power, and make arrangements to fix the damage or wear.

- **Daily:** Make sure all Safety Locks are in good operating condition. Do not use your Lift if the Safety Locks are damaged or excessively worn.
- **Monthly:** Check all labels on the Lift. Replace them if they are illegible or missing.
- **Monthly:** Grease the lubrication points on the Lift. Use white lithium grease or similar.
- **Monthly:** Check Hydraulic Fluid levels. Refill if low.
- **Monthly:** Lubricate the wire rope (Lifting Cables). Use a wire-rope lubricant such as 90-WT gear oil or ALMASOL® Wire Rope Lubricant.
- **Monthly:** Check cable connections, bolts, and pins for proper mounting and torque.
- **Every two months:** Check all Anchor Bolts to make sure they are properly torqued. If they are loose, tighten them.

 **WARNING:** Do not operate your Lift if you find maintenance issues; instead, take the Lift out of service, then contact your dealer, visit [bendpak.com/support](https://www.bendpak.com/support), email [techsupport@bendpak.com](mailto:techsupport@bendpak.com), or call **(800) 253-2363**.

## Wire Rope Inspection and Maintenance

Your Lift's Lifting Cables, which are wire rope, should be inspected regularly:

- Wire rope should be replaced when there are visible signs of damage or extreme wear. *Do not use the Lift if it has damaged or worn Lifting Cables; **take it out of service!***

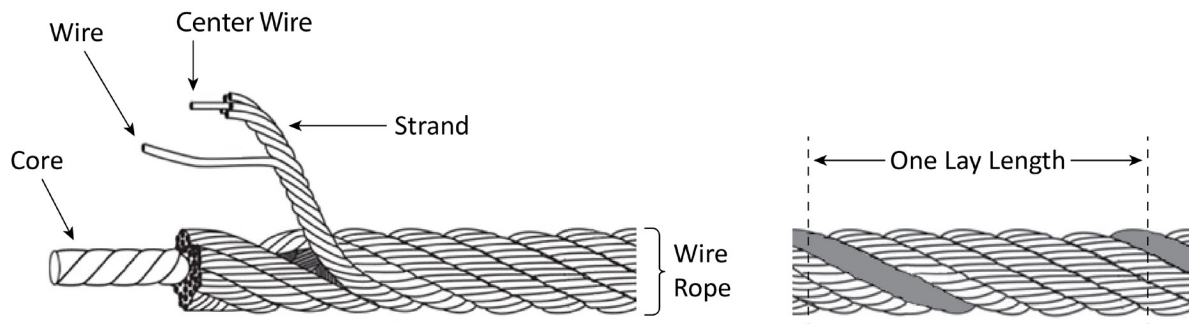

- Wire rope should be maintained in a well-lubricated condition at all times.

Wire rope is only fully protected when each wire strand is lubricated both internally and externally. Excessive wear shortens the life of wire rope. Use a wire-rope lubricant that penetrates to the core of the rope and provides long-term lubrication between each individual strand, such as 90-WT gear oil or ALMASOL® Wire Rope Lubricant. To make sure the inner layers of the rope remain well lubricated, lubrication should be done at least every three months during normal operation.

- All Sheaves and guide rollers that contact moving wire rope should be given regular visual checks for surface wear and lubricated to make sure they run freely. This should be done every three months during normal operation.

For all Sheave axles, use standard wheel bearing grease. For all Sheaves and/or guide rollers, use 90-WT gear oil or a similar heavy lubricant, applied by any method including pump/spray dispensing, brush, hand, or swabbing.

- How often should you inspect?

Wire rope should be visually inspected at least once each day when in use, as suggested by American Petroleum Institute's Recommended Practice 54 guidelines. Any wire rope that meets the criteria for removal must be immediately replaced.

- When should you replace wire rope due to broken wires?

Wire rope should be removed from service if you see six randomly distributed broken wires within any one lay length (where a single strand makes a full turn around the rope) or three broken wires in one strand within one lay length.

- Are there other reasons to replace your wire rope?

Yes. Corrosion that pits the wires and/or connectors, evidence of kinking, crushing, cutting, bird-caging, or a popped core, wear that exceeds 10% of a wire's original diameter, or heat damage.

- How do you find broken wires?

- a. Relax your rope to a stationary position and move the pick-up points off the Sheaves. Clean the surface of the rope with a cloth — a wire brush, if necessary — so you can see any breaks.
- b. Flex the rope to expose any broken wires hidden in the valleys between the strands.
- c. Visually check for any broken wires. One way to check for crown breaks is to run a cloth along the rope to check for possible snags.
- d. With an awl, probe between wires and strands and raise any wires that appear loose.

# Troubleshooting

This section describes how to troubleshoot your Lift.

**Note:** If your Lift is not functioning correctly, you must take it out of service until it is fixed.

**Important:** All repair work **must** be done by qualified personnel.

 **WARNING** The Lift uses electrical energy; if your organization has Lockout/Tagout policies, make sure to implement them before performing any Troubleshooting.

Runways do not raise or do not lower, once raised.	<p>Make sure there is sufficient Hydraulic Fluid in the reservoir.</p> <p>Make sure there is no air in the Hydraulic System.</p> <p>Make sure the Hydraulic Hose is not pinched or leaking.</p> <p>Make sure the Power Unit is getting power.</p> <p>If the Hydraulic Fluid is dirty, replace it with clean fluid.</p> <p>Make sure the Lift is not overloaded.</p>
Runways do not lower past the nearest Safety Lock when pressing and holding the pushbutton.	Problem with the Air Line; check to make sure all sections of the Air Line are connected and not leaking.
One corner of the Lift is lower than the other three corners.	The Safety Lock on the lower corner is not engaged. Raise the Runways up, then lower them down onto the Safety Locks. Check to make sure all four Safety Locks are engaged.
Runways move erratically or squeak when in use.	Move the Runways up and down a few times to flush any residual air from the Hydraulic System. Make sure to pause for at least two minutes between cycles.
Runways do not stay up.	<p>Check for leaking Hydraulic Fluid.</p> <p>Make sure the Runways are engaged on their Safety Locks.</p>
Motor not running.	<p>Check the connection to the power source; make sure it is plugged in and of the appropriate voltage.</p> <p>Make sure the wiring is correct; check the wiring diagram.</p>
Hydraulic Fluid is dirty.	Replace the dirty fluid with clean, approved Hydraulic Fluid, such as Dexron III, Dexron VI, Mercon V, Mercon LV, Shell Tellus S4 / S3 / S2, or comparable.
Runways make odd noises.	Lubricate the bushings on the Sheaves on the sides of the Crosstubes using white lithium grease. If the Lift is new, a break-in period may be needed; run the Lift several times each day. If the noises persist, contact BendPak Support.

If you continue to have issues with your Lift, take it out of service, then contact your dealer, go to [bendpak.com/support](http://bendpak.com/support), email [techsupport@bendpak.com](mailto:techsupport@bendpak.com), or call **(800) 253-2363**.

---

## Bleeding the Hydraulic Cylinder

The Hydraulic Cylinder on the Lift is self-bleeding, which means that in most cases any air in the system can be removed by raising and lowering the Runways a few times; “bleeding” the Hydraulic System of the unwanted air.

 **WARNING** Before performing any maintenance on your Lift (for example, bleeding the Hydraulic Cylinder or adding Hydraulic Fluid), make sure both Runways are on the ground and the power source has been disconnected.

Symptoms of air in the Hydraulic System include Runways moving erratically and/or making odd noises. These could be caused by other situations; refer to **Troubleshooting** for more information.

### To bleed the Hydraulic System:

1. Raise and lower the Runways up to six times; ***pause for at least one minute between each cycle.***

The Lift’s motor cannot run continuously; it is designed for regular use, but not continuous use.

2. Watch the Runways as you raise and lower them.

When the Lift stops moving erratically or stops squeaking, you can stop the bleeding process.

3. Check the Hydraulic Fluid reservoir on the Power Unit.

Bleeding the Hydraulic System may significantly lower the amount of Hydraulic Fluid in the reservoir.

4. Add additional Hydraulic Fluid if necessary.

If your Lift is still moving erratically or making odd noises after bleeding the Hydraulic System, refer to **Troubleshooting** for more information.

# Wiring Diagrams

## 5585280

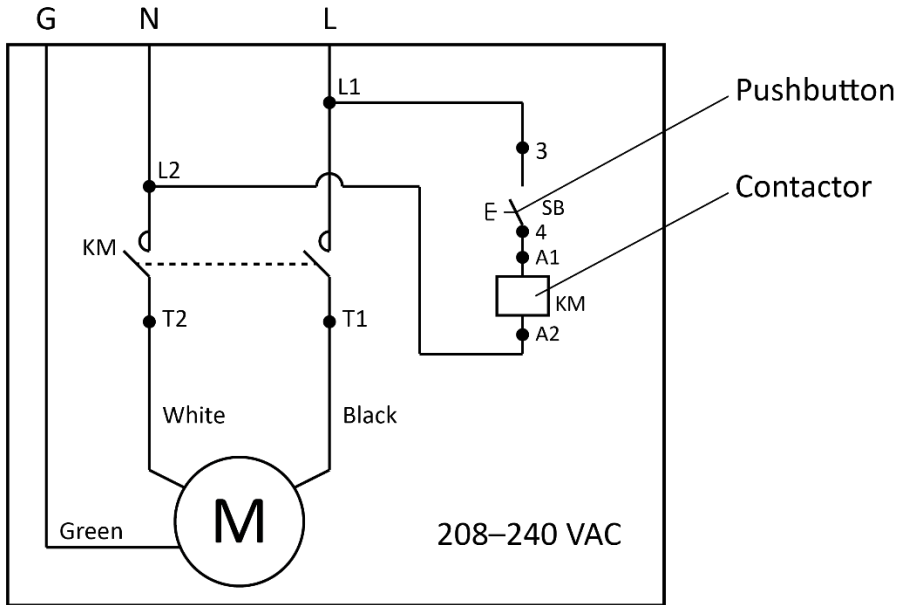

## 5585181

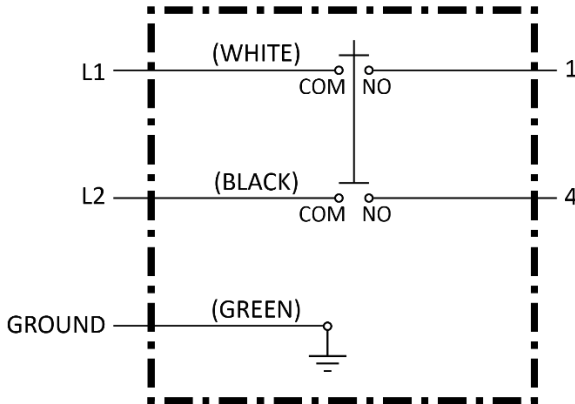

## 5585178

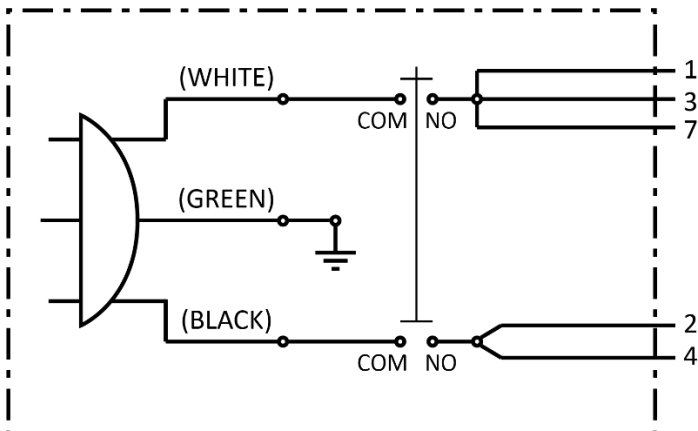

**5585182**

460 VAC

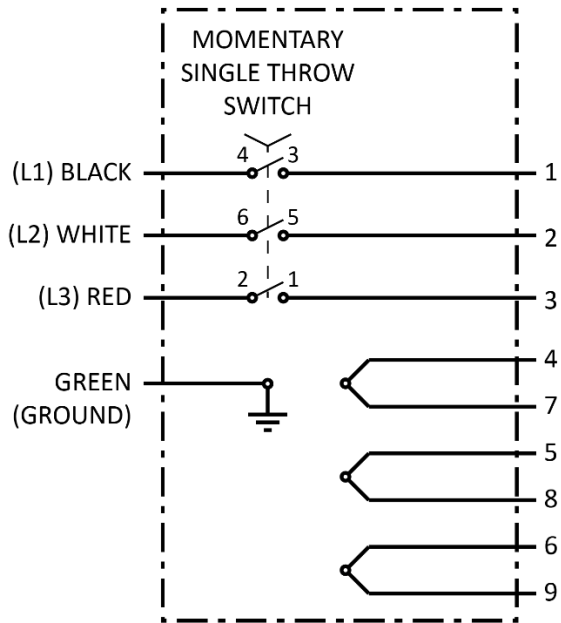

**5585247**

190 / 208-230 VAC

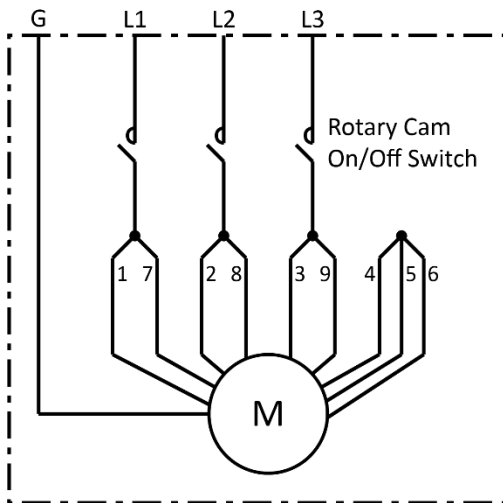

380 / 460 VAC

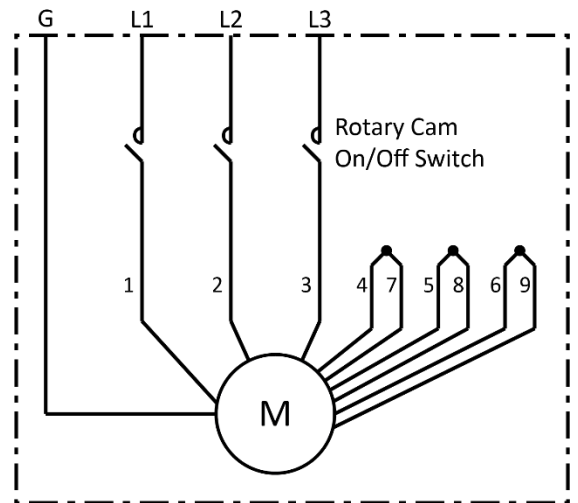

# Labels

**A**



**B**

**⚠ DANGER**

**SAFETY LOCKS ENGAGED — DO TO PROCEED**      **SAFETY LOCK NOT ENGAGED — REMAIN CLEAR**

SAFETY LADDER

SLACK SAFETY  
PRIMARY SAFETY

SAFETY LADDER

SLACK SAFETY  
PRIMARY SAFETY

**VISUALLY CONFIRM THAT ALL PRIMARY SAFETY LOCKS ARE ENGAGED BEFORE ENTERING WORK AREA.**

Support components on this lift are intended to raise and lower lift, they are NOT load-holding devices. Do not go under an elevated lift until visual confirmation is made that the lift is engaged on its Safety Locks. Refer to the manual for proper Safety Lock procedures and additional instructions.

**⚠ WARNING**

**Wire Rope Inspection and Maintenance**

- Replace lifting cables if wear or damage is evident, such as excessive broken strands, kinks, deformities, or areas of heavy abrasion.
- Keep wire rope in a well-lubricated condition at all times. Wire rope is only fully protected when each wire strand is lubricated, both internally and externally. Excessive wear shortens the life of wire rope. Use wire rope lubricant that penetrates to the core of the rope and provides long-term lubrication between individual strands. Lubrication should be done at least every three months during normal operation.
- All sheaves and guide rollers in contact with the moving wire rope should be given regular visual checks for surface wear and lubricated to make sure they run freely. This should be done at least every three months during normal operation. For sheave axles, use standard wheel bearing grease. For all sheaves and/or guide rollers, use 90-WF gear oil or a similar heavy lubricant applied by any method including pumps/spray dispensers, brush, hand, and/or swabbing.

**Failure to read, understand, and follow these instructions may cause death or serious injury. Read and understand these instructions before using lift.**

**IMPORTANT OPERATION / MAINTENANCE INSTRUCTIONS - PLEASE READ**

**TO RAISE LIFT**

- Position vehicle tires at the center of each Platform.
- Set parking brake or use wheel chocks to lock vehicle in position.
- Before raising vehicle, be sure all personnel are clear of lift and surrounding area. Pay careful attention to overhead obstacles.
- Raise lift to desired height by pressing pedal/button on power unit.
- Maintain visual contact with vehicle and surrounding area at all times while raising lift.
- Stop immediately if load shifts or becomes unlevel.
- After vehicle is raised to desired height, lower lift onto the nearest Safety Lock. Do not allow cables to become excessively slack.
- Always make sure all Primary Safety Locks are engaged before entering work area.

**TO LOWER LIFT**

- Make sure all personnel, tools, and equipment are clear of lift and surrounding area.
- Lower lift by pressing pedal/button on power unit. Engage lift at least two inches to allow adequate clearance for hooks to close.
- Press and hold Push-to-Stop At Voice.
- Lower vehicle by auto pressing and holding lowering handle. When lowering lift, make sure that all personnel and objects are high clear.
- Always keep a visual line of sight on lift while lowering.
- Always make sure safety locks are disengaged. If one of the locks inadvertently engage in descent, lift and/or vehicle may slip at causing personal injury or death.

**REQUIRED MONTHLY MAINTENANCE**

- Consult operation manual for factory recommended maintenance.
- Adjust lift cables to ensure lift raises level and Safety Locks engage simultaneously.
- Check all chain/bolt connections, bolts and pins to ensure proper securing.
- Visually inspect Safety Locks for proper operation.
- Visually inspect concrete. Do not use lift if concrete shows signs of breakage or other deterioration.
- Inspect all anchor bolts, re-tilt if necessary.
- Check pins for looseness and pin ends.
- Inspect all bolts and other fasteners to make sure they are properly torqued.
- Make a visual inspection of all moving parts and check for signs of excess wear.
- Replace all lift parts before lift is put back into operation.

**⚠ WARNING**

- Warning: If anchor bolts are loose, or any component of the lift is electric, do not use lift. Do not use lift under these conditions.
- Never operate the lift with people or equipment under it.
- Never exceed rated capacity.
- Always ensure Safety Locks are engaged before use attempt to make lift work on or near vehicle.
- Do not use lift if electrical system engaged on Safety Locks.
- Do not permit the electric motor to get wet. Motor damage caused by dampness is not covered by the warranty.

**C**

**⚠ CAUTION**

Lift to be used by trained operator ONLY.

**⚠ CAUTION**

Authorized personnel only in lift area.

The messages and pictographs shown are generic in nature and are meant to generally represent hazards common to all automotive lifts regardless of specific style.

Funding for the development and validation of these labels was provided by the Automotive Lift Institute, PO Box 85 Cortland, NY 13845. Replacement label sets may be obtained from the original lift manufacturer and ALI's member companies. They are protected by copyright. ALI/ALI 2009 www.ali.org © 2012 by ALI, Inc.

**⚠ WARNING**

Clear area if vehicle is in danger of falling.

**⚠ WARNING**

Remain clear of lift when raising or lowering vehicle.

**⚠ WARNING**

Keep clear of pinch points when lift is moving.

**⚠ WARNING**

Keep feet clear of lift while lowering.

**⚠ WARNING**

Do not override self-closing lift controls.

**⚠ WARNING**

Check wheel to prevent vehicle movement.

The messages and pictographs shown are generic in nature and are meant to generally represent hazards common to all automotive lifts regardless of specific style.

Funding for the development and validation of these labels was provided by the Automotive Lift Institute, PO Box 85 Cortland, NY 13845. Replacement label sets may be obtained from the original lift manufacturer and ALI's member companies. They are protected by copyright. ALI/ALI 2009 www.ali.org © 2012 by ALI, Inc.

**NOTICE**

Read operating and safety manuals before using lift.

**NOTICE**

Proper maintenance and inspection is necessary for safe operation.

**NOTICE**

Do not operate a damaged lift.

The messages and pictographs shown are generic in nature and are meant to generally represent hazards common to all automotive lifts regardless of specific style.

Funding for the development and validation of these labels was provided by the Automotive Lift Institute, PO Box 85 Cortland, NY 13845. Replacement label sets may be obtained from the original lift manufacturer and ALI's member companies. They are protected by copyright. ALI/ALI 2009 www.ali.org © 2012 by ALI, Inc.

**D**

**⚠ DANGER**

**THE MAXIMUM LIFTING CAPACITY FOR THIS LIFT IS DESCRIBED BELOW**

<b>Maximum Lifting Capacity</b> 7000 lbs. / 3175 kg
<b>Max. Lifting Cap. / Front of Lift Center</b> 3500 lbs. / 1588 kg
<b>Max. Lifting Cap. / Rear of Lift Center</b> 3500 lbs. / 1588 kg

**Exceeding the weight capacity of this lift can damage lift and/or property and may cause personal harm, injury or death to operators and/or bystanders. All vehicles MUST be positioned on lift with CENTER OF GRAVITY midway between adapters and/or centered on runways. Damage to lift due to overloading or misuse IS NOT covered under warranty.**

P/N 5905401

**G**

**NOTICE**

If attachments, accessories, or configuration modifying components used on this lift are located in the load path and affect operation of the lift, affect the lift electrical listing, or affect intended vehicle accommodation; and if they are not certified for use on this lift, then the certification of this lift shall become null and void. Contact the participant for information pertaining to certified attachments, accessories, or configuration modifying components.

www.autolift.org ©2011 by ALI, Inc. ALI / WLSIA01

**H**

**CERTIFIED AUTOMOTIVE LIFT**

**ALI CERTIFIED**  
To the provisions of **ANSI/ALI ALCVT-2017**  
SAFETY REQUIREMENTS FOR CONSTRUCTION, TESTING AND VALIDATION

Automotive Lift Institute, Inc. | Cortland, NY 13045

**MET LISTED**  
Conforms to **ANSI/UL 201**  
SAFETY STANDARD FOR GARAGE EQUIPMENT

**MET**®  
NRTL LISTED  
MET Laboratories, Inc.  
BALTIMORE, MD 21236

Certification Label Serial Number  
ALXXSAMPLEXXN

**E**

**⚠ ATTENTION ⚠**

**MAXIMUM LIFTING CAPACITY**

**7000 Lbs.**

**3175 Kg.**

P/N 5905645

**F**

**BP BendPak**  
PROVIDING AUTOMOTIVE SERVICE SOLUTIONS

SANTA PAULA, CA USA  
WWW.BENDPAK.COM

LIFT TYPE: SURFACE MOUNT CAP: MED/HVY DTY MFG: BPK SEE DATA PLATE FOR PRODUCT DETAILS  
POWER: ELECTRIC/HYDRAULIC INSTALLATION - SEE OWNERS GUIDE OR CONTACT FACTORY

SAFETY INSTRUCTIONS: IF ATTACHMENTS, ACCESSORIES OR CONFIGURATION MODIFYING COMPONENTS THAT ARE LOCATED IN THE LOAD PATH, AFFECT OPERATION OF THE LIFT, AFFECT THE LIFT ELECTRICAL LISTING OR AFFECT INTENDED VEHICLE ACCOMMODATION ARE USED ON THIS LIFT AND, IF THEY ARE NOT CERTIFIED FOR USE ON THIS LIFT, THEN THE CERTIFICATION OF THIS LIFT SHALL BECOME NULL AND VOID. CONTACT THE PARTICIPANT FOR INFORMATION PERTAINING TO CERTIFIED ATTACHMENTS, ACCESSORIES OR CONFIGURATION MODIFYING COMPONENTS.

BENDPAK LIFTS ARE SUPPLIED WITH CONCRETE FASTENERS MEETING THE CRITERIA AS PRESCRIBED BY ASTM E488 - 96(2003). LIFT BUYERS ARE RESPONSIBLE FOR ANY SPECIAL REGIONAL STRUCTURAL AND/OR SEISMIC ANCHORING REQUIREMENTS SPECIFIED BY ANY OTHER AGENCIES AND/OR CODES SUCH AS THE UNIFORM BUILDING CODE (UBC) AND/OR INTERNATIONAL BUILDING CODE (IBC).

THE MANUFACTURE, USE, SALE OR IMPORT OF THIS PRODUCT MAY BE SUBJECT TO ONE OR MORE UNITED STATES PATENTS, OR PENDING APPLICATIONS, OWNED BY BENDPAK, INC.  
DO NOT REMOVE ENGINEERED BY BENDPAK INC. USA MADE IN CHINA

**I**

**BP BendPak** Santa Paula, CA USA  
www.bendpak.com

MODEL NUMBER

DESCRIPTION

LIFT CAPACITY DATE OF MFG.

ROLLING JACK MAX CAP. MAX PSI / BAR

VOLTAGE SERIAL NUMBER

110-240V, 50-60 Hz, 1 Ph  
 208-240V, 50-60 Hz, 1 Ph  
 380-415V, 50-60 Hz, 3 Ph  
 208-440V, 50-60 Hz, 3 Ph

UPC

**DANGER!** EAC  
Disconnect Power Before Servicing WARRANTY VOID IF DATA PLATE IS REMOVED PN 5905952



**A**  
Top of  
Each Post

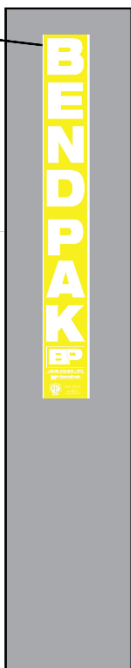

Back of  
Powerside  
Post

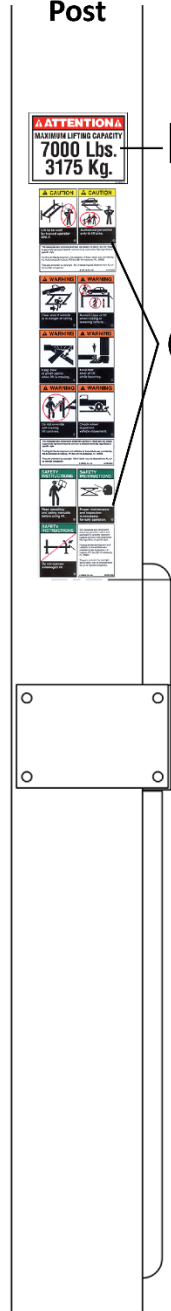

**ATTENTION**  
MAXIMUM LIFTING CAPACITY  
7000 Lbs.  
3175 Kg.

**E**



**C**

Side of  
Powerside  
Post

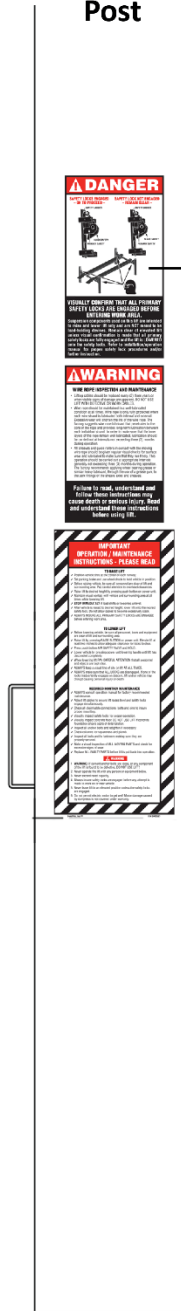

**DANGER**  
BE CAREFUL  
DO NOT  
RELY ON THE  
SAFETY OF THE  
LIFTING MECHANISM.  
STAY CLEAR OF THE  
LIFTING MECHANISM  
WHEN THE LIFT IS  
RAISED.

**B**

**WARNING**  
NEW USER OPERATION AND MAINTENANCE  
INSTRUCTIONS - PLEASE READ  
FAILURE TO READ, UNDERSTAND AND  
FOLLOW THESE INSTRUCTIONS MAY  
RESULT IN SERIOUS INJURY, DEATH  
OR PROPERTY DAMAGE. READ  
AND UNDERSTAND THESE INSTRUCTIONS  
BEFORE USING THE LIFT.

**IMPORTANT  
OPERATION / MAINTENANCE  
INSTRUCTIONS - PLEASE READ!**

Front of  
Powerside  
Post

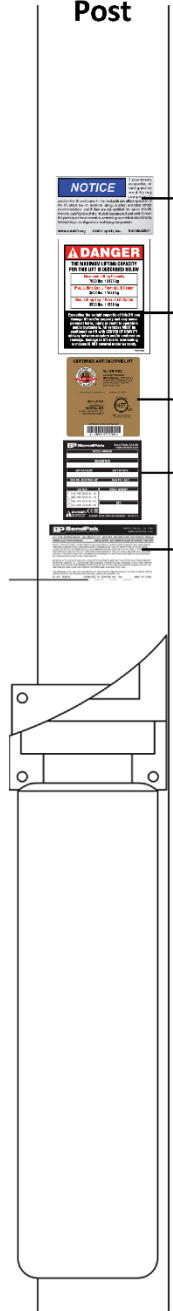

**NOTICE**  
READ THESE INSTRUCTIONS  
BEFORE USING THE LIFT.  
FAILURE TO READ, UNDERSTAND  
AND FOLLOW THESE INSTRUCTIONS  
MAY RESULT IN SERIOUS INJURY,  
DEATH OR PROPERTY DAMAGE.  
READ AND UNDERSTAND THESE  
INSTRUCTIONS BEFORE USING THE  
LIFT.

**G**

**DANGER**  
BE CAREFUL  
DO NOT  
RELY ON THE  
SAFETY OF THE  
LIFTING MECHANISM.  
STAY CLEAR OF THE  
LIFTING MECHANISM  
WHEN THE LIFT IS  
RAISED.

**D**

**IMPORTANT  
OPERATION / MAINTENANCE  
INSTRUCTIONS - PLEASE READ!**

**H**

**EP Powerside**

**I**

**F**

# Parts Drawings

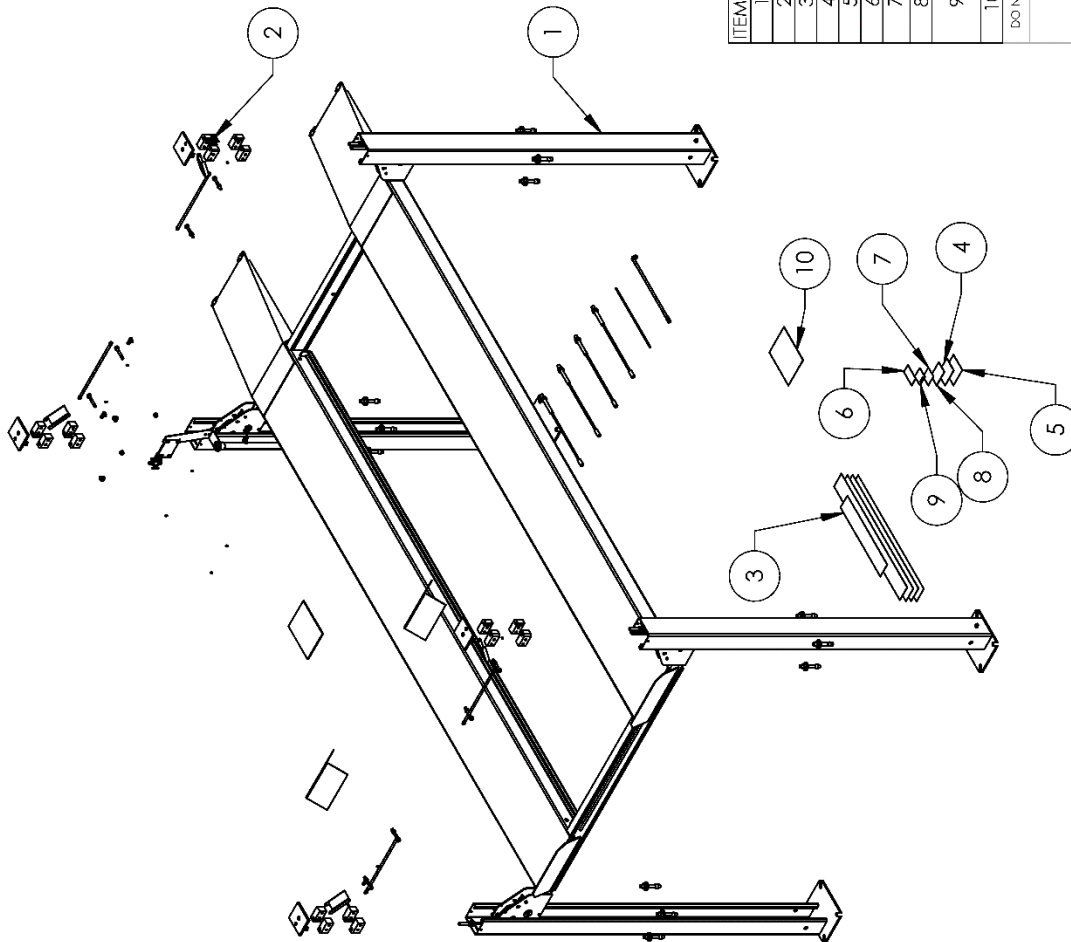

ITEM NO	PART NUMBER	DESCRIPTION	QTY	REV
1	5245388	HD-7P LIFT SUPERSTRUCTURE	1	T
2	5250184	PARTS BOX HD-7P	1	H
3	5905200	4 POST DECAL KIT, LESS ALI	1	B
4	5905401	MAX CAP DANGER 7K	1	--
5	5905465	MANUFACTURER LABEL	1	--
6	5905940	PRODUCT DATA LABEL	1	--
7	5905952	5905952-2015_Serial_Tag-C	1	--
8	5905645	MAX CAP NRTL DANGER 7K	1	--
9	5905653	LABEL: ALL-ALCTV-2017 GOLD LABEL, US; MEI	1	--
10	5905103	WARNING: ALL/WL 200	1	--

DO NOT SCALE DRAWING		NAME	DATE
DRAWN	CHECKED		
THIRD ANGLE PROJECTION			
DIMENSIONS ARE IN MM			

1645 LENOXWOOD DR. SANITA PAULA, GA 93060	
TITLE: HD-7P PRODUCTION LIFT VER E (CE CERT)	
SIZE DWG. NO.	REV
A 5260523	U
SCALE: 1:40	
SHEET 1 OF 2	

PROPERTY AND CONFIDENTIAL  
 INFORMATION. NO REPRODUCTION OR  
 DISSEMINATION OF THIS DRAWING OR  
 ANY PART THEREOF IS PERMITTED  
 WITHOUT THE WRITTEN PERMISSION OF BENDPAK INC. ©  
 2019 BENDPAK INC.

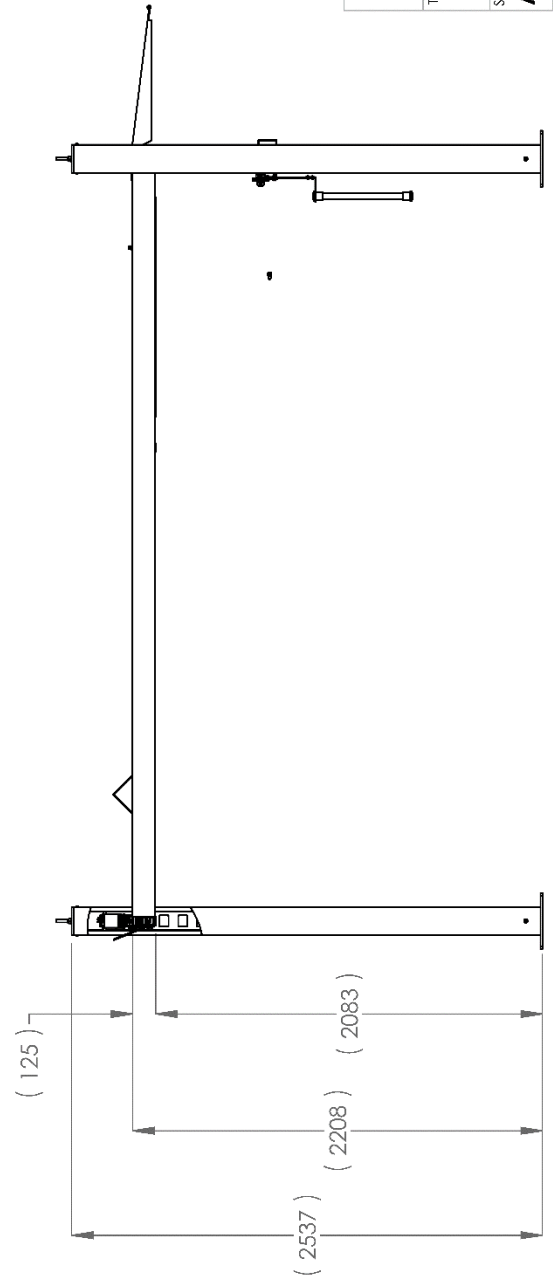
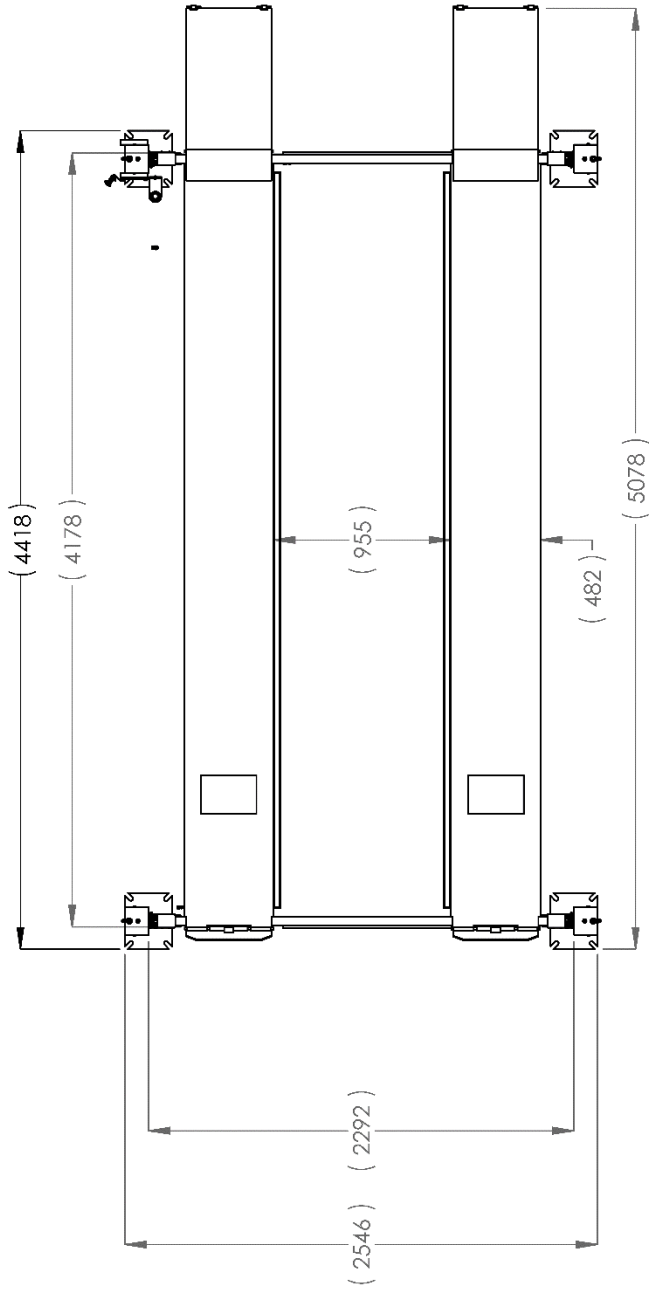

**BendPak**  
 1445 LEMONWOOD DR.  
 SANTA PAULA, CA 93060

TITLE: HD-7P PRODUCTION  
 LIFT VER E (CE CERT)

SIZE DWG. NO. A 5260523 REV U

SCALE: 1:35 SHEET 2 OF 2

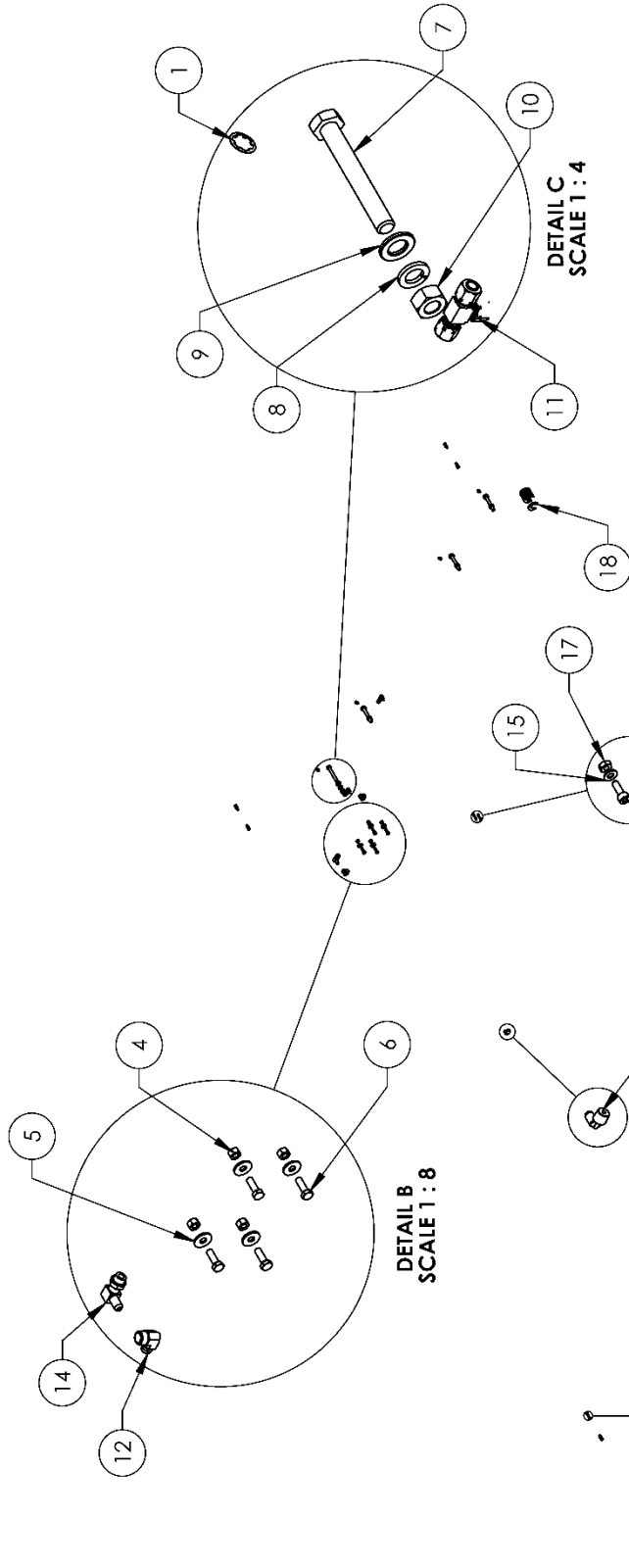

ITEM NO.	PART NUMBER	DESCRIPTION	QTY.	REV
1	5505031	ROTOR CLIP 12mm SS	0	-
2	5507256	HHB M6 x 1.25	0	-
3	5535359	NUT M6 x 1.6 NPT	0	-
4	5535360	NUT M8 x 1.25 NPT	4	A
5	5445340	WASHER M8 x 24 FLAT	4	B
6	5530010	HHB M8 x 1.25 x 25	0	-
7	5530009	HHB M12 x 1.75 x 90 CI 8.8	0	-
8	5445201	WASHER M12 SPRING LOCK	0	-
9	5445347	WASHER M12 FLAT WASHER	0	-
10	5535354	NUT M12 x 1.75	0	-
11	5550395	FIG TEE -04 COMP x -04 COMP x -04 COMP	3	-
12	5550089	FIG FLB -04 COMP x -06 NPT	2	-
13	5550106	FIG FLB -04 JIC -06 NPT	1	-
14	5550008	FIG FLB -04 JIC -06 ORB	1	-
15	5445009	WASHER 04.3 x 09mm x 0.8mm	2	-
16	5530008	SHCS M4 x 0.7 x 12 BOC	2	-
17	5535010	NUT M4 x 0.7	2	-
18	5545335	C WASHER SHIM FOR LIFTS	20	-

1645 LEMONWOOD DR.  
 BENDPAK CORPORATION SANTA PAULA, CA 93060

TITLE: HD-7 SERIES PARTS BAG  
 SIZE DWG. NO. A 5174092  
 REV E

SCALE: 1:30 SHEET 1 OF 1

DO NOT SCALE DRAWING  
 DIMENSIONS ARE IN MM

DRAWN: \_\_\_\_\_  
 CHECKED: \_\_\_\_\_  
 NAME: \_\_\_\_\_ DATE: \_\_\_\_\_

THIRD ANGLE PROJECTION

MATERIAL: \_\_\_\_\_  
 SIZE: \_\_\_\_\_

PROPRIETARY AND CONFIDENTIAL  
 THIS INFORMATION CONTAINS TRADE SECRETS, DRAWINGS, AND  
 TECHNICAL INFORMATION OF BENDPAK CORPORATION. IT IS TO BE KEPT  
 CONFIDENTIAL AND NOT TO BE REPRODUCED OR DISCLOSED TO ANY OTHER  
 PERSONS WITHOUT THE WRITTEN PERMISSION OF BENDPAK CORPORATION.

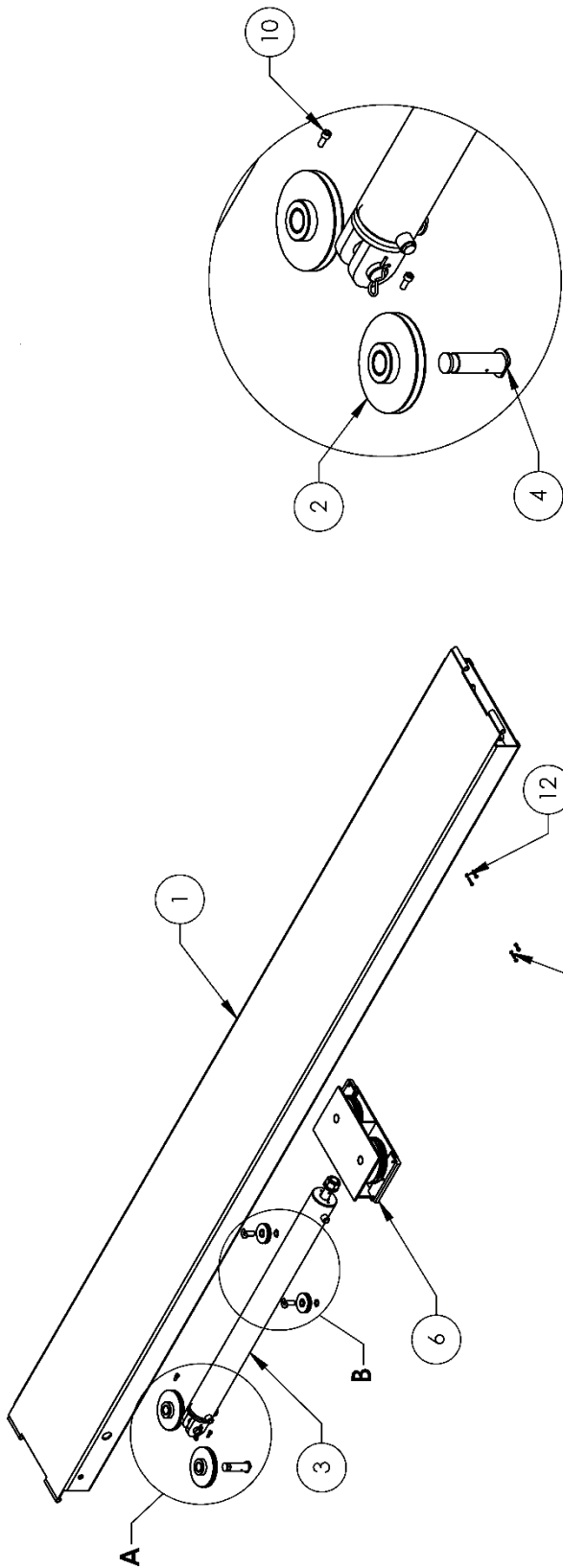

**DETAIL A**  
SCALE 1 : 10

**DETAIL B**  
SCALE 1 : 10

ITEM NO	PART NUMBER	DESCRIPTION	QTY	REV
1	5600202	HD-7P POWER SIDE RAMP WELDMENT	1	G
2	5215122	HD-7/7500/9 SERIES SINGLE SHEAVE ROLLER ASSEMBLY	2	E
3	5502112	CYLINDER ASSEMBLY Ø3.5 x 41	1	G
4	5600900	HD-7/7500/9 SERIES RAMP SHEAVE SHAFT WELDMENT	4	D
5	5575103	HD-7P SERIES 76mm DIRECTION SHEAVE	2	D
6	5215186	HD-7 SERIES PULL BOX ASSEMBLY	1	F
7	5215185	HD-7P SERIES TWIN SHEAVE ASSEMBLY	2	C
8	5600301	HD-7 SERIES DIRECTIONAL SHEAVE PIN WELDMENT	2	B
9	5505032	ROTOR CLIP 18mm SS	2	--
10	5530076	SHCS M8 x 1.25 x 20mm	4	--
11	5530047	HHB, M6 x 1 x 30mm/L	4	--
12	5535357	NUT M6 x 1.0 NL	4	--

DO NOT SCALE DRAWING	NAME	DATE
DRAWN		
CHECKED		
THIRD ANGLE PROJECTION		
<b>BP BendPak.</b> 1645 LEMMONWOOD DR. SANTA PAULA, CA 93060		
DIMENSIONS ARE IN MM		
TITLE: HD-7P/W POWER SIDE RAMP ASSEMBLY		
SIZE DWG. NO. A 5215170		
REV T		
SCALE: 1:25		
SHEET 1 OF 2		

PROPERTY AND CONFIDENTIAL INFORMATION OF BENDPAK INC. ANY REPRODUCTION OR USE OF THIS DRAWING WITHOUT THE WRITTEN PERMISSION OF BENDPAK INC. IS PROHIBITED.

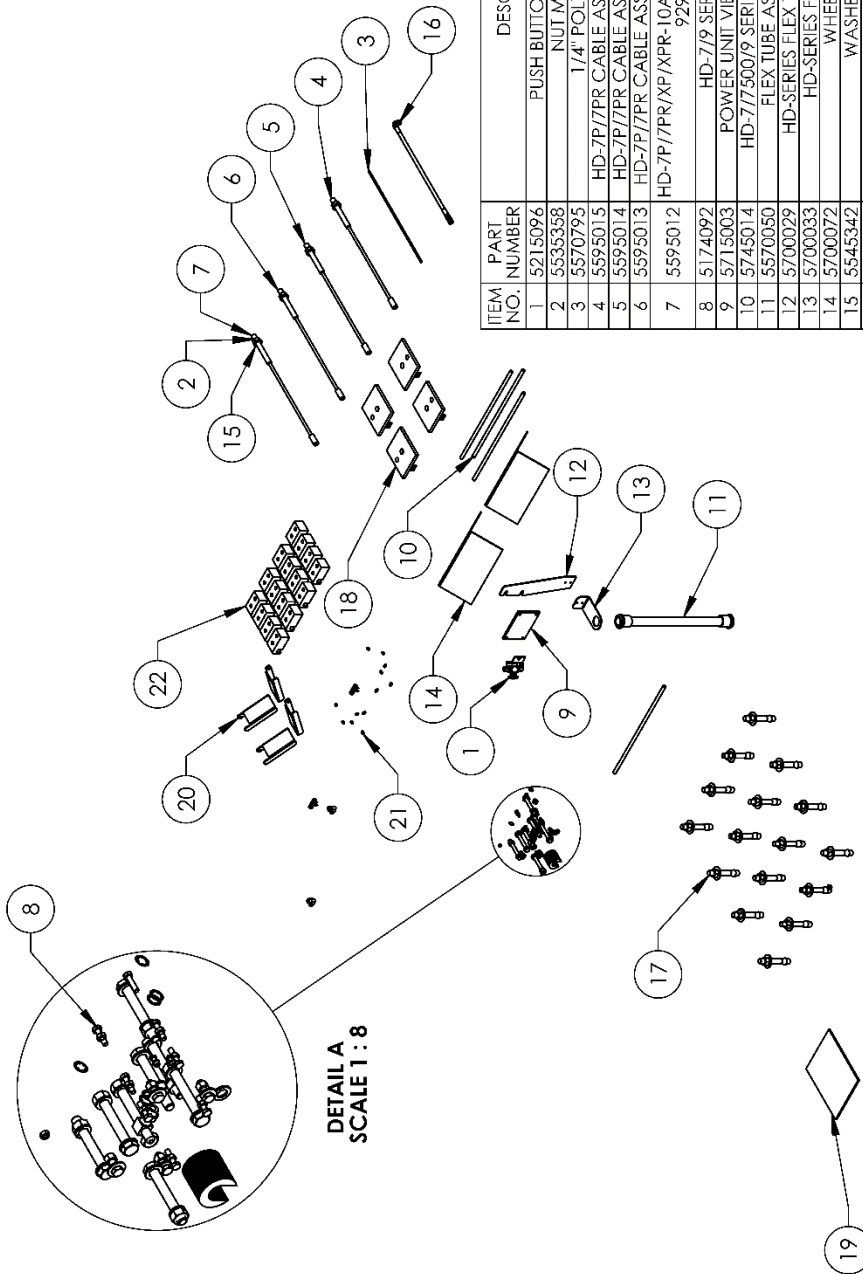

DETAIL A  
SCALE 1 : 8

ITEM NO.	PART NUMBER	DESCRIPTION	QTY.	REV
1	5215096	PUSH BUTTON AIR ASSEMBLY	1	G
2	5535388	NUT M18 x 2.5NL	4	-
3	5570795	1/4" POLY-FLO TUBING	17000*mm	-
4	5595015	HD-7P/7PR CABLE ASSEMBLY Ø10 x 6494mm ST	1	F
5	5595014	HD-7P/7PR CABLE ASSEMBLY Ø10 x 5086mm ST	1	F
6	5595013	HD-7P/7PR CABLE ASSEMBLY Ø10 x 10674mm ST	1	F
7	5595012	HD-7P/7PR/XP/10ACX CABLE ASSEMBLY Ø10 x 9290mm ST	1	F
8	5174092	HD-7/9 SERIES PARTS BAG	1	E
9	5715003	POWER UNIT VIBRATION DAMPENER	1	B
10	5745014	HD-7/7500/9 SERIES DRIVE UP RAMP PIN	4	B
11	5570050	FLEX TUBE ASSEMBLY 1320mm	1	B
12	5700029	HD-SERIES FLEX TUBE BRACKET PLATE	1	F
13	5700033	HD-SERIES FLEX TUBE ANGLE	1	E
14	5700072	WHEEL CHOCK	2	B
15	5545342	WASHER M18 FLAT	4	-
16	5570874	HD-7P HYD. HOSE ASSY Ø6.4 x 2492mm	1	D
17	5530456	AB 3/4" x 4 - 3/4"	16	-
18	5600405	HD-7P/7500/9 SERIES TOP PLATE WELDMENT	4	C
19	5900041	HD-7 SERIES INSTALLATION MANUAL	1	-
20	5716630	HD-9 SERIES CROSSTUBE COVER, PLASTIC	4	A
21	5550025	FTG GRS M6 x 1.0	12	-
22	5716005	HD-7/7500/9/14/HDSO-14 POLYETHYLENE SLIDE BLOCK	16	L

**BendPak.**  
 1645 LEMONWOOD DR.  
 SANTA PAULA, CA 95060

TITLE: PARTS BOX HD-7P  
 SIZE DWG. NO. A  
 REV 5250184  
 SCALE: 1:25  
 SHEET 1 OF 1

DO NOT SCALE DRAWING  
 DIMENSIONS ARE IN MM  
 THIRD ANGLE PROJECTION  
 PROPRIETARY AND CONFIDENTIAL  
 THE SCALE PROPERTY OF BENDPAK INC. ANY REPRODUCTION WITHOUT THE WRITTEN PERMISSION OF BENDPAK INC. IS PROHIBITED.

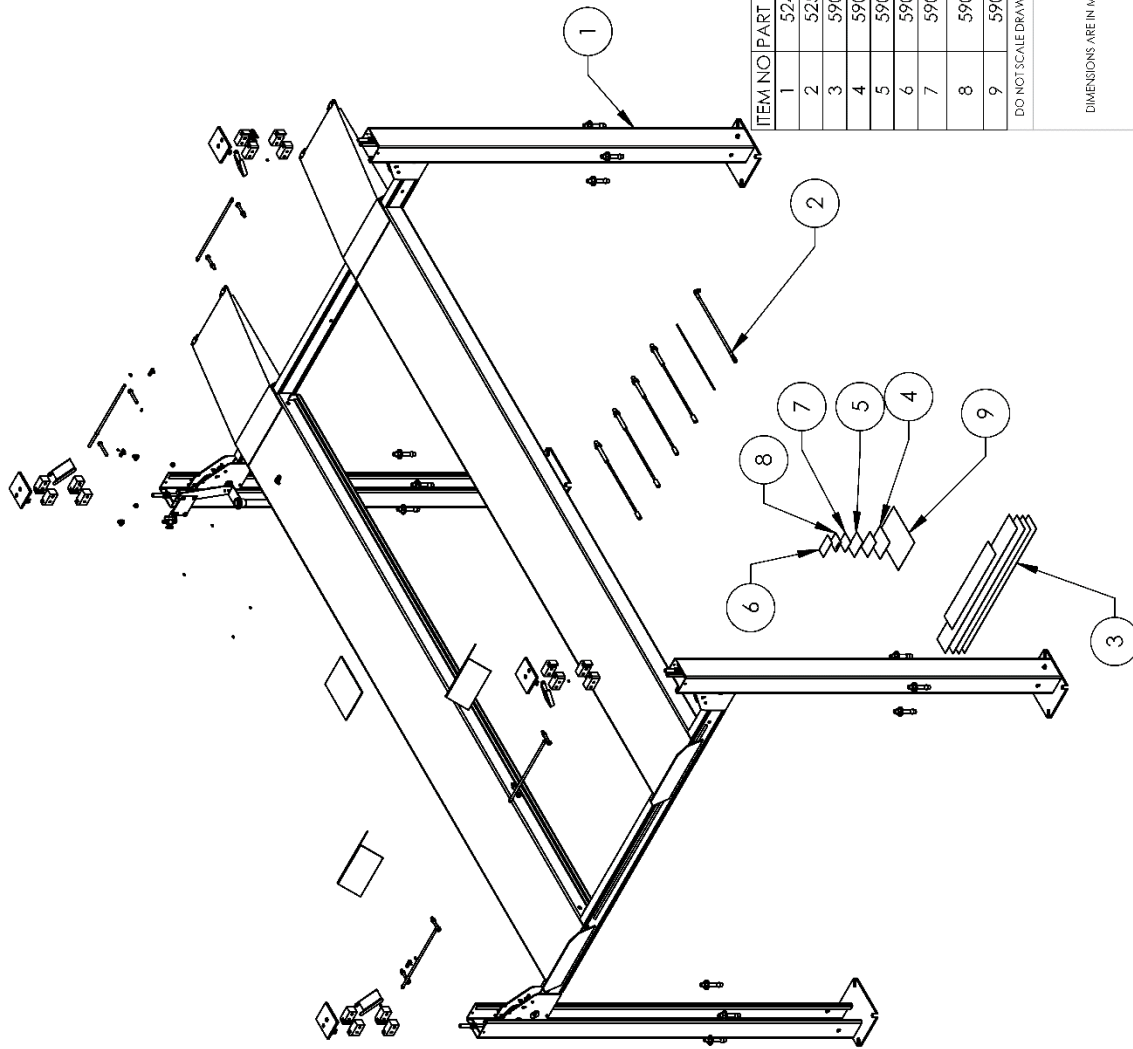

ITEM NO	PART NUMBER	DESCRIPTION	QTY	REV
1	5245384	HD-7W LIFT SUPERSTRUCTURE	1	U
2	5250164	PARTS BOX HD-7W	1	H
3	5905200	4 POST DECAL KIT, LESS ALI	1	B
4	5905465	MANUFACTURER LABEL	1	---
5	5905645	MAX CAP NRTL DANGER 7K	2	---
6	5905940	PRODUCT DATA LABEL	1	---
7	5905952	5905952-2015_Serial_Tag-C	1	---
8	5905653	LABEL: ALI-ALCTV-2017 GOLD LABEL, US; MET LABS	1	---
9	5905103	WARNING ALI/WL 200	1	---

**BP BendPak.**  
1645 LEMONWOOD DR.  
SANTA PAULA, CA 93060

**HD-7W PRODUCTION LIFT VER D (CE CERT)**

SIZE DWG. NO. **A** 5260515

REV **T**

SCALE: 1:35 SHEET 1 OF 2

DO NOT SCALE DRAWING

NAME \_\_\_\_\_ DATE \_\_\_\_\_

DRAWN \_\_\_\_\_

CHECKED CA

THIRD ANGLE PROJECTION

PROPRIETARY AND CONFIDENTIAL  
THIS DOCUMENT IS THE PROPERTY OF BENDPAK, INC. AND IS NOT TO BE REPRODUCED OR TRANSMITTED IN ANY FORM OR BY ANY MEANS, ELECTRONIC OR MECHANICAL, INCLUDING PHOTOCOPYING, RECORDING, OR BY ANY INFORMATION STORAGE AND RETRIEVAL SYSTEM.

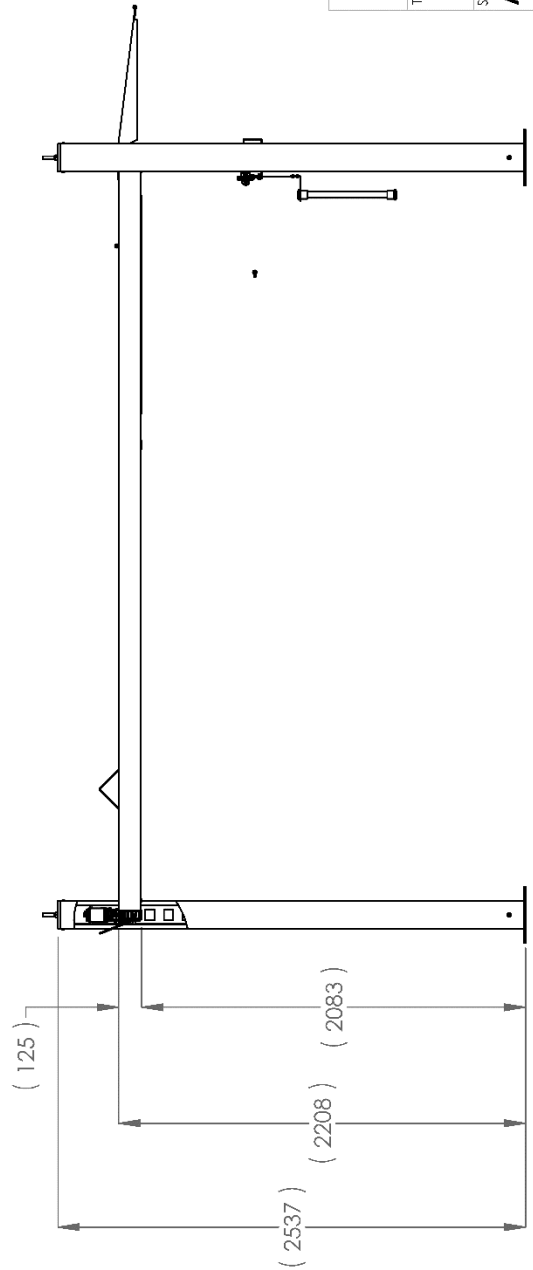
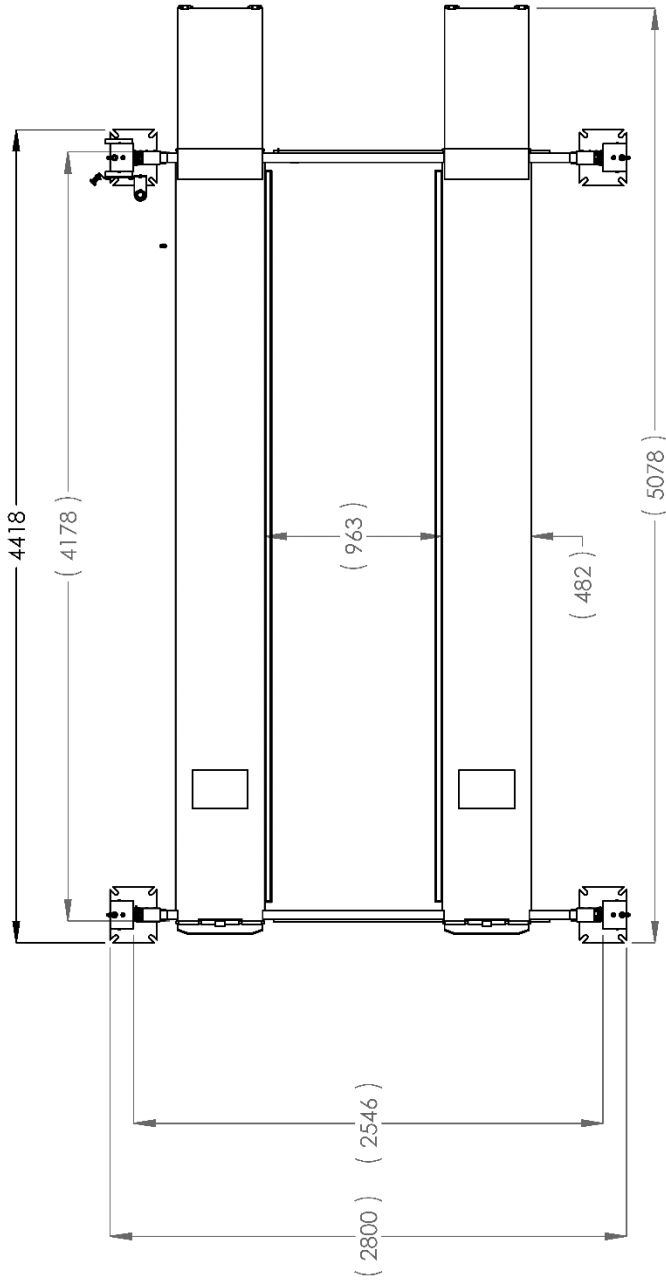

		1645 LEMMONWOOD DR. SANTA PAULA, CA 93060	
TITLE: HD-7W PRODUCTION LIFT VER D (CE CERT)			
SIZE DWG. NO.	A	5260515	REV T
SCALE: 1:35			SHEET 2 OF 2



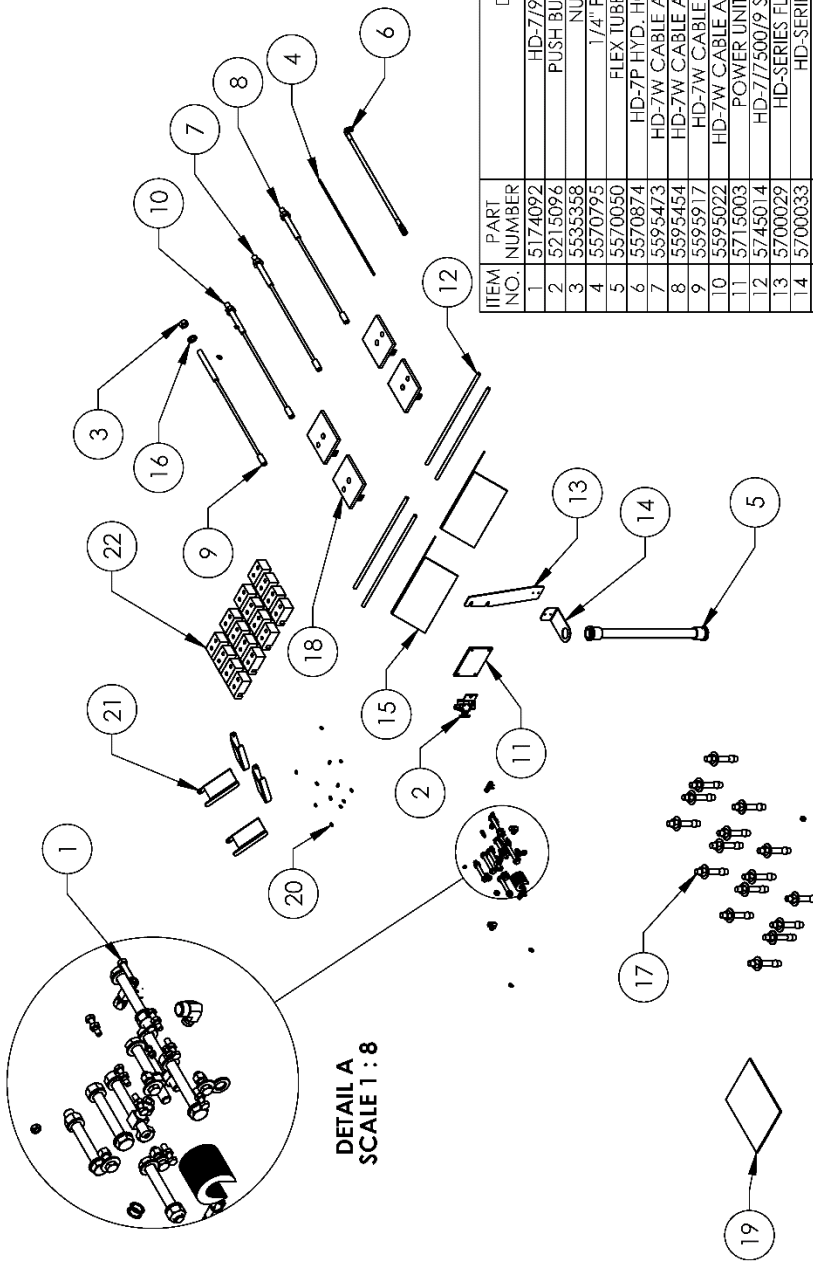

DETAIL A  
SCALE 1 : 8

ITEM NO.	PART NUMBER	DESCRIPTION	QTY.	REV
1	5174092	HD-7/P SERIES PARTS BAG	1	E
2	5215096	PUSH BUTTON AIR ASSEMBLY	1	G
3	5535358	NUT M18 X 2.5 NL	4	-
4	5570795	1/4" POLY-FLO TUBING	17000*	mm
5	5570050	FLEX TUBE ASSEMBLY 1320mm	1	B
6	5570874	HD-7P HYD. HOSE ASSY Ø6.4 x 2492mm	1	D
7	5595473	HD-7W CABLE ASSEMBLY Ø10 x 5099mm ST	1	C
8	5595454	HD-7W CABLE ASSEMBLY Ø10 x 6724mm ST	1	D
9	5595917	HD-7W CABLE ASSEMBLY Ø10 x 9271mm	1	E
10	5595022	HD-7W CABLE ASSEMBLY Ø10 x 10897mm ST	1	J
11	5715003	POWER UNIT VIBRATION DAMPENER	1	B
12	5745014	HD-7/500/P SERIES DRIVE UP RAMP PIN	4	B
13	5700029	HD-SERIES FLEX TUBE BRACKET PLATE	1	F
14	5700033	HD-SERIES FLEX TUBE ANGLE	1	E
15	5700072	WHEEL CHOCK	2	B
16	5545342	WASHER M18 FLAT	4	-
17	5530456	AB 3/4" x 4 - 3/4"	16	-
18	5600405	HD-7P/7500/P SERIES TOP PLATE WELDMENT	4	C
19	5900041	HD-7 SERIES INSTALLATION MANUAL	1	-
20	5550025	FIG GRS M6 x 1.0	12	-
21	5716630	HD-9 SERIES CROSSTUBE COVER, PLASTIC	4	A
22	5716005	HD-7/7500/P/14/HD50-14 POLYETHYLENE SLIDE	16	L

DO NOT SCALE DRAWING

DRAWN \_\_\_\_\_ DATE \_\_\_\_\_

CHECKED \_\_\_\_\_

THIRD ANGLE PROJECTION

PROPERTY AND CONFIDENTIAL INFORMATION OF BENDPAK INC. ANY REPRODUCTION IN PART OR AS A WHOLE WITHOUT THE WRITTEN PERMISSION OF BENDPAK INC. IS PROHIBITED.

1645 LEMONWOOD DR.  
SANTA PAULA, CA 93060

**BendPak**

TITLE: PARTS BOX HD-7W

SIZE DWG. NO. A

REV H

SCALE: 1:25

SHEET 1 OF 1

# Automotive Lift Institute (ALI) Store

You probably checked the [ALI's Directory of Certified Lifts](http://www.autolift.org/ali-directory-of-certified-lifts/) (www.autolift.org/ali-directory-of-certified-lifts/) before making your most recent Lift purchase, but did you know the **ALI Store** (www.autolift.org/ali-store/) offers a wide variety of professional, easy-to-use, and reasonably priced training and safety materials that will make your garage a safer place to work?

**The ALI Store is your trusted source for workplace safety!**

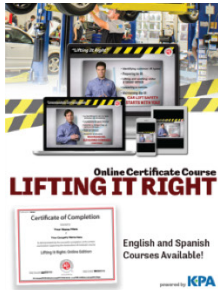

**Lifting It Right Online Certificate Course.** Make sure you and your people are lifting vehicles the right way.

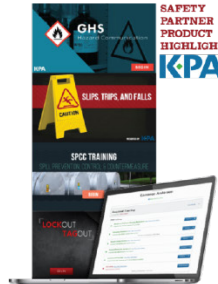

**KPA Online Training Subscription.** Get all of your people up to speed on automotive industry topics.

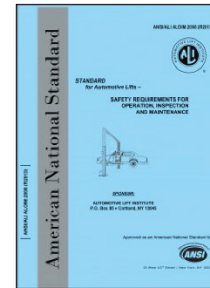

**ANSI/ALI ALOIM Standard for Automotive Lifts.** Safety Requirements for Operation, Inspection, and Maintenance.

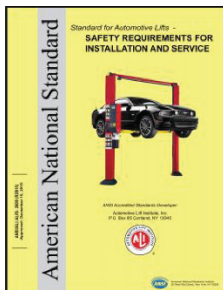

**ANSI/ALI ALIS Standard.** Safety Requirements for Installation and Service.

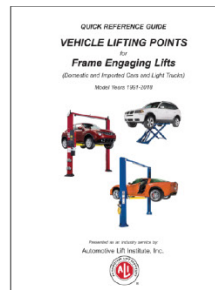

**Guide to Hitting Vehicle Lifting Points for Frame-Engaging Lifts.** Don't eyeball your lifting points, **know** where they are.



**Lift Operator Safety Materials.** Five safety documents in a single package.

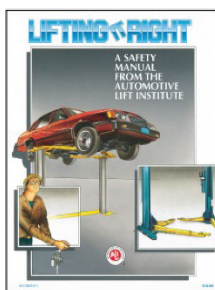

**Lifting It Right.** A hardcopy version of the *Lifting It Right* safety manual from the Automotive Lift Institute.



**Uniform Warning Labels and Placards for 2-Posts.** Labels in Mandarin, French Canadian, and Spanish are also available.



**Safety Tips Card.** Reminds your people of 13 key safety tips to follow daily.

**Visit today and get the training and materials you need to work safely:**  
[http://www.autolift.org/ali-store/.](http://www.autolift.org/ali-store/)





1645 Lemonwood Drive  
Santa Paula, CA, 93060 USA