



EUROPEAN USERS

400V 50Hz SUPPLY DETAILS ARE INCLUDED WITH ELECTRICAL CONTROL BOX. DISREGARD SUPPLY WIRING DETAILS IN THIS MANUAL

IMPORTANT SAFETY INSTRUCTIONS SAVE THESE INSTRUCTIONS

PLEASE READ THE ENTIRE CONTENTS OF THIS MANUAL PRIOR TO INSTALLATION AND OPERATION. BY PROCEEDING WITH LIFT INSTALLATION AND OPERATION YOU AGREE THAT YOU FULLY UNDERSTAND AND COMPREHEND THE FULL CONTENTS OF THIS MANUAL. FORWARD THIS MANUAL TO ALL OPERATORS. FAILURE TO OPERATE THIS EQUIPMENT AS DIRECTED MAY CAUSE INJURY OR DEATH.

MAN REV A 07-13-2016
P/N 5900370

INSTALLATION AND OPERATION MANUAL

12,000/15,000/18,000 LB / 5443/6804/8165 KG CAPACITY
SURFACE MOUNTED TWO-POST LIFTS

MODELS:

XPR-12CL
XPR-12CL-192
XPR-12CL-LWB
XPR-12CL-LWB-192
XPR-15CL
XPR-15CL-192
XPR-18CL
XPR-18CL-192



READ FIRST



Do not operate this machine until you read and understand all the dangers, warnings and cautions in this manual.



ORIGINAL INSTRUCTIONS IN ENGLISH LANGUAGE

Keep this operation manual near the machine at all times. Make sure that ALL USERS read this manual.

RECEIVING

The shipment should be thoroughly inspected as soon as it is received. The signed Bill of Lading is acknowledgement by the shipping carrier as receipt of this product as listed in your invoice as being in a good condition of shipment. If any of these goods listed on this Bill of Lading are missing or damaged, do not accept goods until the shipping carrier makes a notation on the freight bill of the missing or damaged goods. Do this for your own protection.

BE SAFE

Your new lift was designed and built with safety in mind. However, your overall safety can be increased with proper training and thoughtful operation on the part of the operator. DO NOT operate or repair this equipment without reading this manual and the important safety instructions shown inside. Keep this operation manual near the lift at all times. Make sure that ALL USERS read and understand this manual.



1645 Lemonwood Dr.
Santa Paula, CA. 93060, USA
Toll Free 1-800-253-2363
Tel: 1-805-933-9970
www.bendpak.com

TWO-POST SURFACE MOUNTED AUTO AND TRUCK LIFT

This instruction manual has been prepared especially for you.
Your new lift is the product of over 40 years of continuous research, testing and development;
it is the most technically advanced lift on the market today.

READ THIS ENTIRE MANUAL BEFORE INSTALLATION & OPERATION BEGINS.

RECORD HERE THE LIFT AND
POWER UNIT INFORMATION WHICH IS
LOCATED ON THE SERIAL NUMBER
DATA PLATES ON THE LIFT AND
ON THE POWER UNIT

Power Unit Model # _____
Power Unit Date Of Mfg. _____
Power Unit Serial # _____
Max Operating Pressure 2,060 PSI

This information is required when
calling for parts or warranty issues.

PRODUCT WARRANTY

Our comprehensive product warranty means more than a commitment to you; it's also a commitment to the value of your new BendPak lift. For full warranty details and to register your new lift contact your nearest BendPak dealer or visit <http://www.bendpak.com/support/warranty/>

What is not covered under this warranty:

- Any failure that results from Purchaser's abuse, neglect or failure to operate, maintain or service product in accordance with instructions provided in the owner's manual(s) supplied.
- Any damage caused by overloading lift beyond rated capacity.
- Items or service normally required to maintain the product, i.e. lubricants, oil, etc.
- Items considered general wear parts such as rubber pads, lifting cables, etc. unless wear or failure is a direct result of manufacturer defect due to material and/or workmanship.
- Any component damaged in shipment or any failure caused by installing or operating lift under conditions not in accordance with installation and operation guidelines or damaged by contact with tools or surroundings.
- Motor or pump failure caused by rain, excessive humidity, corrosive environments or other contaminants.
- Rusted components due to improper maintenance or corrosive environments.
- Cosmetic defects that do not interfere with product functionality.
- Damage due to incorrect voltage or improper wiring.
- Any incidental, indirect, or consequential loss, damage or expense that may result from any defect, failure or malfunction of BendPak Inc. product.
- All electrical components (excluding power unit) are guaranteed for one year against defects in workmanship and/or materials when the lift is installed and used according to specifications.

NOTE:

Every effort has been taken to ensure complete and accurate instructions have been included in this manual, however, possible product updates, revisions and or changes may have occurred since this printing. BendPak Ranger reserves the right to change specifications without incurring any obligation for equipment previously or subsequently sold. Not responsible for typographical errors.

IMPORTANT NOTICE

Do not attempt to install this lift if you have never been trained on basic automotive lift installation procedures. Never attempt to lift components without proper lifting tools such as forklift or cranes. Stay clear of any moving parts that can fall and cause injury. These instructions must be followed to ensure proper installation and operation of your lift. Failure to comply with these instructions can result in serious bodily harm and void product warranty. Manufacturer will assume no liability for loss or damage of any kind, expressed or implied resulting from improper installation or use of this product.



**PLEASE READ ENTIRE MANUAL
PRIOR TO INSTALLATION**

DEFINITIONS OF HAZARD LEVELS

Identify the hazard levels used in this manual with the following definitions and signal words:



Watch for this symbol: It Means: Immediate hazards which will result in severe personal injury or death.



Watch for this symbol: It Means: Hazards or unsafe practices which could result in severe personal injury or death.



Watch for this symbol: It Means: Hazards or unsafe practices which may result in minor personal injury, product or property damage.

OWNER'S RESPONSIBILITY

To maintain the lift and user safety, the responsibility of the owner is to read and follow these instructions:

- ◆ Follow all installation and operation instructions.
- ◆ Make sure installation conforms to all applicable Local, State, and Federal Codes, Rules, and Regulations; such as State and Federal OSHA Regulations and Electrical Codes.
- ◆ Carefully check the lift for correct initial function.
- ◆ Read and follow the safety instructions. Keep them readily available for machine operators.
- ◆ Make certain all operators are properly trained, know how to safely and correctly operate the unit, and are properly supervised.
- ◆ Allow unit operation only with all parts in place and operating safely.
- ◆ Carefully inspect the unit on a regular basis and perform all maintenance as required.
- ◆ Service and maintain the unit only with authorized or approved replacement parts.
- ◆ Keep all instructions permanently with the unit and all decals on the unit clean and visible.

BEFORE YOU BEGIN

Receiving:

The shipment should be thoroughly inspected as soon as it is received. The signed bill of lading is acknowledgement by the carrier of receipt in good condition of shipment covered by your invoice. If any of the goods called for on this bill of lading are shorted or damaged, do not accept them until the carrier makes a notation on the freight bill of the shorted or damaged goods. Do this for your own protection.

NOTIFY THE CARRIER AT ONCE if any hidden loss or damage is discovered after receipt and request the carrier to make an inspection. If the carrier will not do so, prepare a signed statement to the effect that you have notified the carrier (on a specific date) and that the carrier has failed to comply with your request.

IT IS DIFFICULT TO COLLECT FOR LOSS OR DAMAGE AFTER YOU HAVE GIVEN THE CARRIER A CLEAR RECEIPT. File your claim with the carrier promptly. Support your claim with copies of the bill of lading, freight bill, invoice, and photographs, if available. Our willingness to assist in helping you process your claim does not make BendPak responsible for collection of claims or replacement of lost or damaged materials.

TABLE OF CONTENTS

Contents	Page No.
Warranty / Serial Number Information	2
Definitions of Hazard Levels	3
Owner's Responsibility	3
Before You Begin	3
Installer/Operator Agreement/ Protective Equipment	5
Safety / Warning Instructions	6
Tools Required	7
Step 1 / Selecting Site	7
Step 2 / Floor Requirements / Concrete Specifications	7
Assembly View / Description of Parts	8
Floor Plan	9-10
Clearances	11
Step 3 / Column Preparation	12-13
Equalizer Cable Routing	13
Hose Routing	14
Step 4 / Site Layout	15
Step 5 / Installing Power Side Column	16
Step 6 / Installing Off Side Column	16
Step 7 / Mounting The Overhead Assembly	17
Step 8 / Mounting The Hydraulic Power Unit	17-18
Step 9 / Installing the Safeties and Safety Cable	18-19
Step 10 / Installing Hydraulic Lines	20
Step 11 / Routing the Equalizer Cables	20-21
Step 12 / Installing Overhead Microswitch	21-22
Step 13 / Installing Power Unit Hose Assembly and Power Side Safety Cover	22-23
Step 14 / Installing the Lift Arms	23-24
Carriage Stop Bolt Installation Warning.	25
Step 15 / Power Unit Connection	26-28
Step 16 / Lift Start Up Final Adjustments	28
Post Installation Checklist	29
Step 17 / Lubrication.	29
Step 18 / Bleeding the Cylinders	29
Optional Equipment Installation.	30-32
Step 19 / Operation/ Maintenance	33-43
Troubleshooting Guide	44-47
Torque Recommendations	47
Installation Form	48
Part Number Lists	49-74
CE Certificate	75
Certificate of Compliance	76
Warranty	77

**INSTALLER / OPERATOR
PLEASE READ AND FULLY
UNDERSTAND.
BY PROCEEDING YOU AGREE TO
THE FOLLOWING:**

- ◆ I have visually inspected the site where the lift is to be installed and verified the concrete to be in good condition and free of cracks or other defects. I understand that installing a lift on cracked or defective concrete could cause lift failure resulting in personal injury or death.
- ◆ I understand that a level floor is required for proper installation and level lifting.
- ◆ I understand that I am responsible if my floor is of questionable slope and that I will be responsible for all charges related to pouring a new level concrete slab if required and any charges.
- ◆ I understand that Bendpak lifts are supplied with concrete fasteners meeting the criteria of the American National Standard "Automotive Lifts - Safety Requirements for Construction, Testing, and Validation" ANSI/ALI ALCTV-2011, and that I will be responsible for all charges related to any special regional structural and/or seismic anchoring requirements specified by any other agencies and/or codes such as the Uniform Building Code (UBC) and/or International Building Code (IBC).
- ◆ I will assume full responsibility for the concrete floor and condition thereof, now or later, where the above equipment model(s) are to be installed. Failure to follow danger, warning, and caution instructions may lead to serious personal injury or death to operator or bystander or damage to property.
- ◆ I understand that BendPak lifts are designed to be installed in indoor locations only. Failure to follow installation instructions may lead to serious personal injury or death to operator or bystander or damage to property or lift.



Failure to follow danger, warning, and caution instructions may lead to serious personal injury or death to operator or bystander or damage to property.



THIS SYMBOL POINTS OUT IMPORTANT SAFETY INSTRUCTIONS WHICH IF NOT FOLLOWED COULD ENDANGER THE PERSONAL SAFETY AND/OR PROPERTY OR YOURSELF AND OTHERS AND CAN CAUSE PERSONAL INJURY OR DEATH. READ AND FOLLOW ALL INSTRUCTIONS IN THIS MANUAL BEFORE ATTEMPTING TO OPERATE THIS MACHINE.



Please read entire manual prior to installation. Do not operate this machine until you read and understand all the dangers, warnings and cautions in this manual. For additional copies or further information, contact:

BendPak Inc. / Ranger Products
1645 Lemonwood Dr.
Santa Paula, CA. 93060
1-805-933-9970
www.bendpak.com

**INSTALLER / OPERATOR
PROTECTIVE EQUIPMENT**

Personal protective equipment helps makes installation and operation safer, however, it does not take the place of safe operating practices. Always wear durable work clothing during any installation and/or service activity. Shop aprons or shop coats may also be worn, however loose fitting clothing should be avoided. Tight fitting leather gloves are recommended to protect technician hands when handling parts. Sturdy leather work shoes with steel toes and oil resistant soles should be used by all service personnel to help prevent injury during typical installation and operation activities.



Eye protection is essential during installation and operation activities. Safety glasses with side shields, goggles, or face shields are acceptable. Everyday eyeglasses only have impact resistant lenses, they are not safety glasses. Back belts provide support during lifting activities and are also helpful in providing worker protection. Consideration should also be given to the use of hearing protection if service activity is performed in an enclosed area, or if noise levels are high.

INTRODUCTION

1. Carefully remove the crating and packing materials. **CAUTION!** Be careful when cutting steel banding material as items may become loose and fall causing personal harm or injury.

2. Check the voltage, phase and proper amperage requirements for the motor shown on the motor plate. Wiring should be performed by a certified electrician only.

IMPORTANT SAFETY INSTRUCTIONS

Read these safety instructions entirely.

IMPORTANT NOTICE

Do not attempt to install this lift if you have never been trained on basic automotive lift installation procedures.

Never attempt to lift components without proper lifting tools such as forklift or cranes.

Stay clear of any moving parts that can fall and cause injury.

1. Read and understand all instructions and all safety warnings before operating lift.

2. Care must be taken as burns can occur from touching hot parts.

3. Do not operate equipment with a damaged cord or if the equipment has been dropped or damaged until it has been examined by a qualified service person.

4. Do not let a cord hang over the edge of the table, bench, or counter or come in contact with hot manifolds or moving fan blades.

5. If an extension cord is necessary, a cord with a current rating equal to or more than that of the equipment should be used. Cords rated for less current than the equipment may overheat. Care should be taken to arrange the cord so that it will not be tripped over or pulled.

6. Always unplug equipment from electrical outlet when not in use. Never use the cord to pull the plug from the outlet. Grasp plug and pull to disconnect.

7. Let equipment cool completely before putting away. Loop cord loosely around equipment when storing.

8. To reduce the risk of fire, do not operate equipment in the vicinity of open containers of flammable liquids (gasoline).

9. Adequate ventilation should be provided when working on operating internal combustion engines.

10. Keep hair, loose clothing, fingers, and all parts of body away from moving parts. Keep feet clear of lift when lowering. Avoid pinch points.

11. **DANGER!** To reduce the risk of electric shock, do not use on wet surfaces or expose to rain. The power unit used on this lift contains high voltage. Disconnect power at the receptacle or at the circuit breaker switch before performing any electrical repairs. Secure plug so that it cannot be accidentally plugged in during service. or mark circuit breaker switch so that it cannot be accidentally switched on during service.

12. Use only as described in this manual.

Use only manufacturer's recommended attachments.



13. **ALWAYS WEAR SAFETY GLASSES.** Everyday eyeglasses only have impact resistant lenses, they are not safety glasses.

14. Consider work environment. Keep work area clean. Cluttered work areas invite injuries. Keep areas well lit.

15. Guard against electric shock. This lift must be grounded while in use to protect operator from electric shock. Never connect the green power cord wire to a live terminal. This is for ground only.

16. Only trained operators should operate this lift. All non-trained personnel should be kept away from the work area. Never let non-trained personnel come in contact with, or operate lift.

17. **DO NOT** override self-closing lift controls.

18. Clear area if vehicle is in danger of falling.

19. **ALWAYS** make sure the safeties are engaged before attempting to work on or near a vehicle.

21. **WARNING! RISK OF EXPLOSION.** This equipment has internal arcing or sparking parts which should not be exposed to flammable vapors. This machine should not be located in a recessed area or below floor level.

22. **MAINTAIN WITH CARE.** Keep lift clean for better and safer performance. Follow manual for proper lubrication and maintenance instructions. Keep control handles and/or buttons dry, clean and free from grease and oil.

23. Check for damaged parts. Check for alignment of moving parts, breakage of parts or any condition that may affect operation of lift. Do not use lift if any component is broken or damaged.

24. **NEVER** remove safety related components from the lift. Do not use lift if safety related components are missing or damaged.

23. **STAY ALERT.** Use common sense and watch what you are doing. Remember, **SAFETY FIRST.**



SAVE THESE INSTRUCTIONS

TOOLS REQUIRED

- ◆ Rotary Hammer Drill or Similar
- ◆ 3/4" Masonry Bit
- ◆ Hammer
- ◆ 4 Foot Level
- ◆ Open-End Wrench Set: SAE/Metric
- ◆ Socket And Ratchet Set: SAE/Metric
- ◆ Hex-Key / Allen Wrench Set
- ◆ Large Crescent Wrench
- ◆ Large Pipe Wrench
- ◆ Crow Bar
- ◆ Chalk Line
- ◆ Medium Flat Screwdriver
- ◆ Tape Measure: 25 Foot Minimum
- ◆ Needle Nose Pliers

IMPORTANT NOTICE

These instructions must be followed to ensure proper installation and operation of your lift. Failure to comply with these instructions can result in serious bodily harm and void product warranty. Manufacturer will assume no liability for loss or damage of any kind, expressed or implied resulting from improper installation or use of this product.

PLEASE READ ENTIRE MANUAL PRIOR TO INSTALLATION

STEP 1

(Selecting Site)

Before installing your new lift, check the following.

1. **LIFT LOCATION:** Always use architects plans when available. Check layout dimension against floor plan requirements making sure that adequate space is available.
2. **OVERHEAD OBSTRUCTIONS:** The area where the lift will be located should be free of overhead obstructions such as heaters, building supports, electrical lines etc.
3. **DEFECTIVE FLOOR:** Visually inspect the site where the lift is to be installed and check for cracked or defective concrete.



4. **OPERATING TEMPERATURE.** Operate lift only between temperatures of 41° -104° F.
5. Lift is designed for **INDOOR INSTALLATION ONLY.** Outdoor use permitted only if covered and dry. Always follow warnings illustrated on equipment labels.

STEP 2

(Floor Requirements)



This lift must be installed on a solid level concrete floor with no more than 3-degrees of slope. Failure to do so could cause personal injury or death.

A level floor is suggested for proper use and installation and level lifting. If a floor is of questionable slope, consider a survey of the site and/or the possibility of pouring a new level concrete slab.



- ◆ **DO NOT** install or use this lift on any asphalt surface or any surface other than concrete.
- ◆ **DO NOT** install or use this lift on expansion seams or on cracked or defective concrete.
- ◆ **DO NOT** install or use this lift on a second / elevated floor without first consulting building architect.

CONCRETE SPECIFICATIONS

LIFT MODEL	CONCRETE REQUIREMENTS
12,000 Lb Models	6" Min. Thickness / 3,000 PSI
15,000 Lb Models	6" Min. Thickness / 3,000 PSI
18,000 Lb Models	8" Min. Thickness / 3,000 PSI



All models **MUST** be installed on 3000 PSI concrete only conforming to the minimum requirements shown above.
New concrete must be adequately cured by at least 28 days minimum.

IMPORTANT NOTE:

BendPak lifts are supplied with installation instructions and concrete fasteners meeting the criteria as prescribed by the American National Standard "Automotive Lifts - Safety Requirements for Construction, Testing, and Validation" ANSI/ALI ALCTV-2011. Lift buyers are responsible for any special regional structural and/or seismic anchoring requirements specified by any other agencies and/or codes such as the Uniform Building Code (UBC) and/or International Building Code (IBC).

! DANGER

When removing the lift from shipping angles pay close attention as the posts can slide and can cause injury. Prior to removing the bolts make sure the posts are held securely by a fork lift or some other heavy lifting devise.

PARTS INVENTORY
Be sure to take a complete inventory of parts prior to beginning installation.

Description	Qty
Overhead Assembly	1
Arm Assemblies	4
Frame Contact Pads	4
Frame Cradle Pads	4
Offside Column with Lift Head Assembly	1
Powerside Column with Lift Head Assembly	1
Column Extension Weldments (-192 Models ONLY)	2
Hydraulic Cylinder	2
Parts Box (Packing List Enclosed)	1
Parts Bag (Packed in Part Box)	1
Hydraulic Power Unit	1

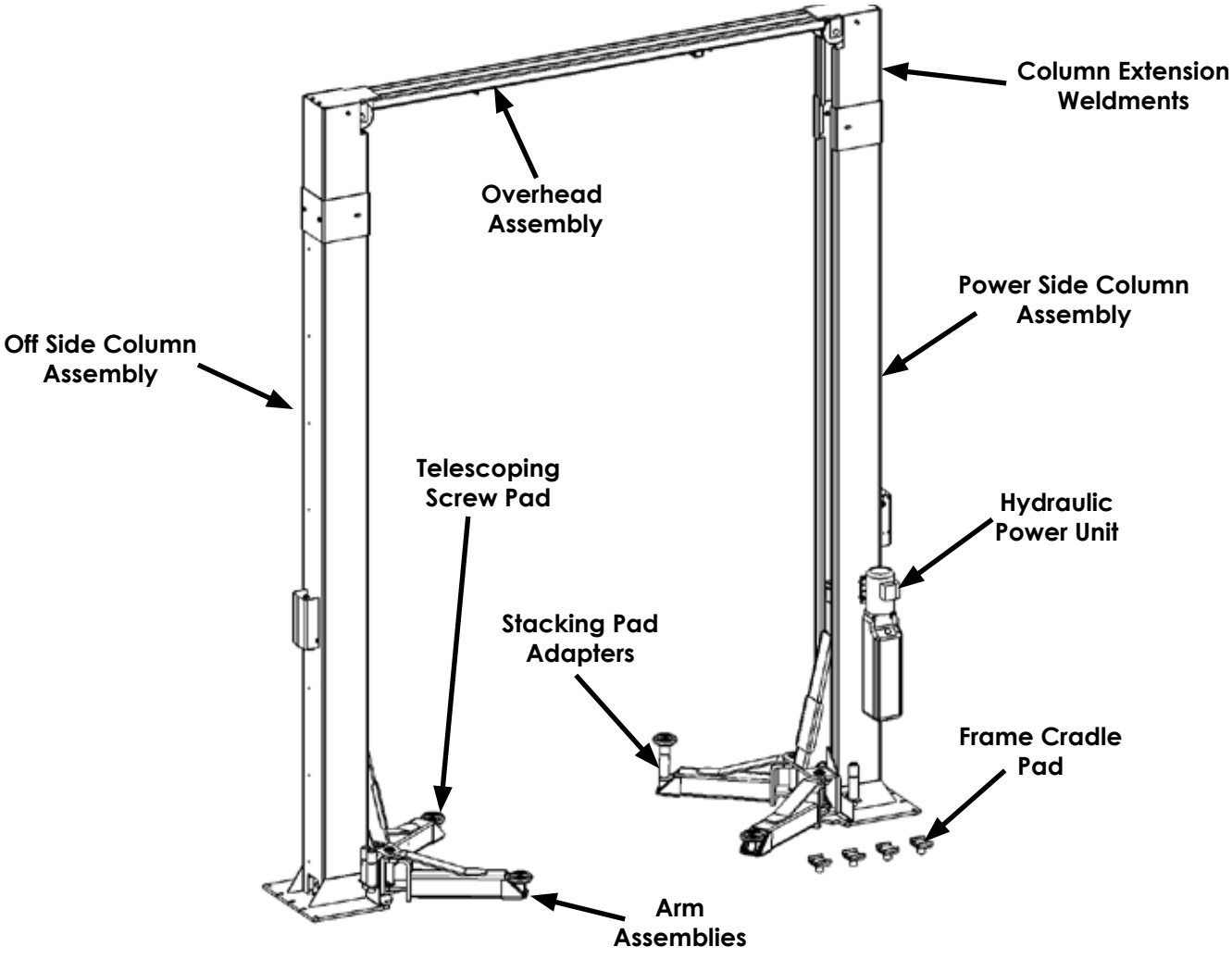

FLOOR PLAN

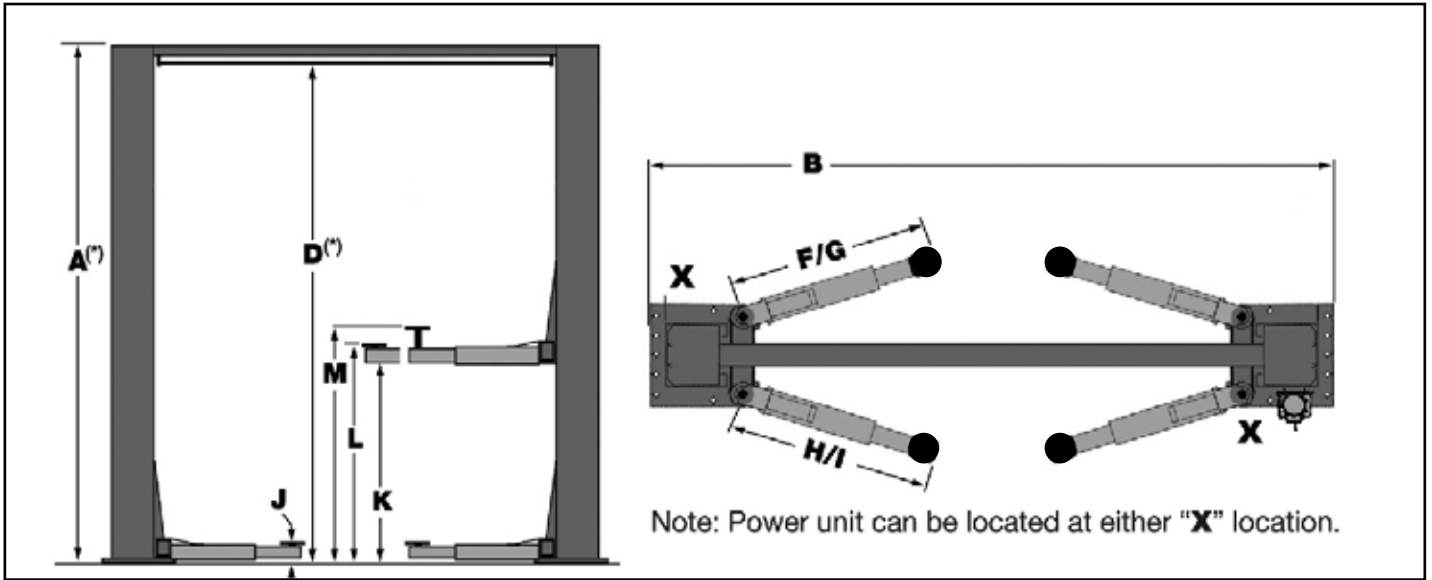

MODEL	XPR-12CL	XPR-12CL-192	XPR-12CL-LWB	XPR-12CL-LWB-192
Lifting Capacity	12,000Lbs. / 5443Kg.	12,000Lbs. / 5443Kg.	12,000Lbs./ 5443Kg.	12,000Lbs. / 5443Kg.
Max Capacity/ Front Axle	6,000 lbs. / 2722 Kg.	6,000 lbs. / 2722 Kg.	6,000 lbs. / 2722 Kg.	6,000 lbs. / 2722 Kg.
Max Capacity/ Rear Axle	6,000 lbs. / 2722 Kg.	6,000 lbs. / 2722 Kg.	6,000 lbs. / 2722 Kg.	6,000 lbs./ 2722 Kg.
A- Height Overall:	170" / 4318 mm. (*)	192.7" / 4895 mm.	170" / 4318 mm. (*)	192.7" / 4895 mm.
B -Width Overall	155" / 3937 mm.	155" / 3937 mm.	155" / 3937 mm.	155" / 3937 mm.
D- Floor to Overhead Switch:	165" / 4191 mm. (*)	187.7" / 4768 mm.	165" / 4191 mm. (*)	187.7" / 4768 mm.
F -Reach (Front Arm Min.):	32" / 813 mm.	32" / 813 mm.	35-1/2" / 902 mm.	35-1/2" / 902 mm.
G -Reach (Front Arm Max.):	60" / 1524 mm.	60" / 1524 mm.	71-1/2" / 1819 mm.	71-1/2" / 1819 mm.
H- Reach (Rear Arm Min.):	32" / 813 mm.	32" / 813 mm.	35-1/2" / 902 mm.	35-1/2" / 902 mm.
I- Reach (Rear Arm Max.):	60" / 1524 mm.	60" / 1524 mm.	71-1/2" / 1819 mm.	71-1/2" / 1819 mm.
J- Min. Pad Height:	5" / 127 mm.	5" / 127 mm.	5" / 127 mm.	5" / 127 mm.
K- Rise:	69" / 1753 mm.	69" / 1753 mm.	69" / 1753 mm.	69" / 1753 mm.
L -Max Lift Height (Pad Only):	74" / 1880 mm.	74" / 1880 mm.	74" / 1880 mm.	74" / 1880 mm.
M - Max Lift Height (6" Adapter):	80" / 2032 mm.	80" / 2032 mm.	80" / 2032 mm.	80" / 2032 mm.
Standard Motor(**)	220VAC / 60Hz.1Ph.	220VAC / 60Hz.1Ph.	220VAC / 60Hz.1Ph.	220VAC / 60Hz.1Ph.
Time of Full Rise:	45 Seconds	45 Seconds	45 Seconds	45 Seconds
Max Load Per Arm:	3,000 Lbs." / 1361 Kg.	3,000 Lbs." / 1361 Kg.	3,000 Lbs." / 1361 Kg.	3,000 Lbs." / 1361 Kg.
Emission sound pressure at Operator Position < 70 dB(A)				
* An optional bolt-on top extension for column raises the overhead bar an additional 24". Must be ordered from factory at time of order.				
** For CE compliant countries see errata sheet included with control panel.				
The design, material and specifications are subject to change without notice.				

FLOOR PLAN

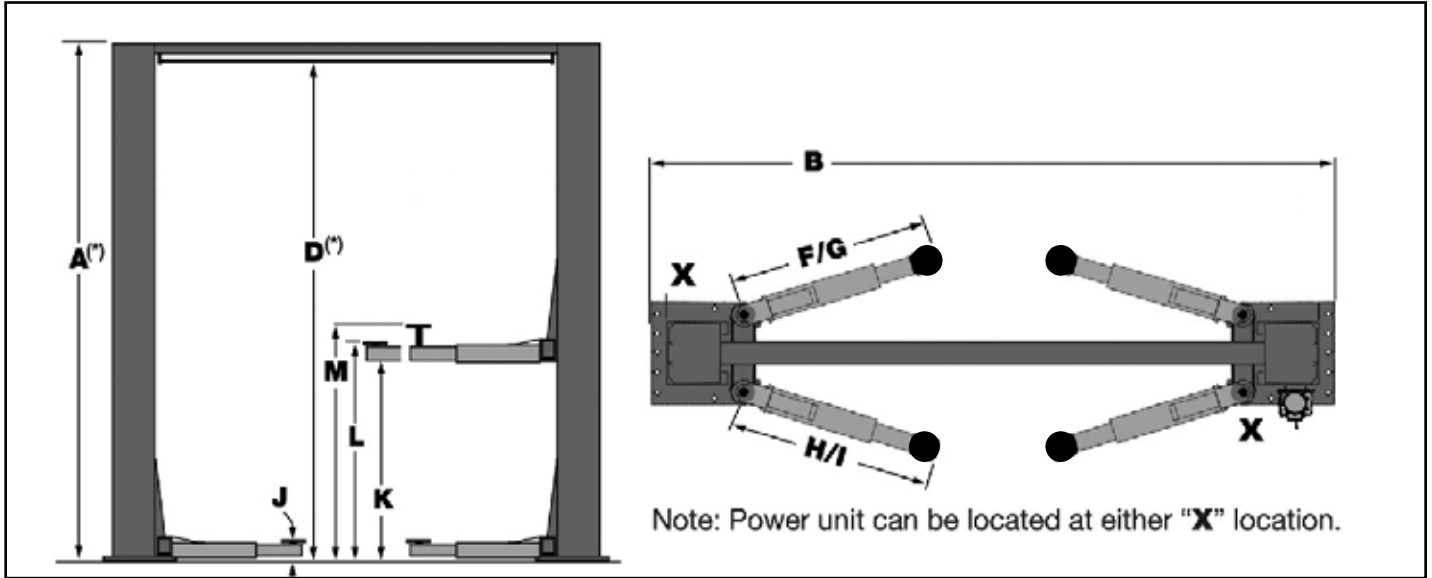

MODEL	XPR-15CL	XPR-15CL-192	XPR-18CL	XPR-18CL-192
Lifting Capacity	15,000Lbs. / 6804Kg.	15,000Lbs. / 6804Kg.	18,000Lbs. / 8165Kg.	18,000Lbs. / 8165Kg.
Max Capacity/ Front Axle	7,500 lbs. / 3402 Kg.	7,500 lbs. / 3402 Kg.	9,000 lbs. / 4082 Kg.	9,000 lbs. / 4082 Kg.
Max Capacity/ Rear Axle	7,500 lbs. / 3402 Kg.	7,500 lbs. / 3402 Kg.	9,000 lbs. / 4082 Kg.	9,000 lbs. / 4082 Kg.
A- Height Overall:	170" / 4318 mm. (*)	192.7" / 4895 mm.	170" / 4318 mm. (*)	192.7" / 4895 mm.
B -Width Overall	155" / 3937 mm.	155" / 3937 mm.	155" / 3937 mm.	155" / 3937 mm.
D- Floor to Overhead Switch:	165" / 4191 mm. (*)	187.7" / 4768 mm.	165" / 4191 mm. (*)	187.7" / 4768 mm.
F -Reach (Front Arm Min.):	39" / 991 mm.	39" / 991 mm.	39" / 991 mm.	39" / 991 mm.
G -Reach (Front Arm Max.):	60" / 1524 mm.	60" / 1524 mm.	60" / 1524 mm.	60" / 1524 mm.
H- Reach (Rear Arm Min.):	39" / 991 mm.	39" / 991 mm.	39" / 991 mm.	39" / 991 mm.
I- Reach (Rear Arm Max.):	60" / 1524 mm.	60" / 1524 mm.	60" / 1524 mm.	60" / 1524 mm.
J- Min. Pad Height:	5" / 127 mm.	5" / 127 mm.	5" / 127 mm.	5" / 127 mm.
K- Rise:	69" / 1753 mm.	69" / 1753 mm.	69" / 1753 mm.	69" / 1753 mm.
L -Max Lift Height (Pad Only):	74" / 1880 mm.	74" / 1880 mm.	74" / 1880 mm.	74" / 1880 mm.
M - Max Lift Height (6" Adapter):	80" / 2032 mm.	80" / 2032 mm.	80" / 2032 mm.	80" / 2032 mm.
Standard Motor(**)	220VAC / 60Hz.1Ph.	220VAC / 60Hz.1Ph.	220VAC / 60Hz.1Ph.	220VAC / 60Hz.1Ph.
Time of Full Rise:	45 Seconds	45 Seconds	45 Seconds	45 Seconds
Max Load Per Arm:	3,750 Lbs. / 1701 Kg.	3,750 Lbs. / 1701 Kg.	4,500 Lbs. / 2041 Kg	4,500 Lbs. / 2041 Kg
Emission sound pressure at Operator Position < 70 dB(A)				
* An optional bolt-on top extension for column raises the overhead bar an additional 24". Must be ordered from factory at time of order.				
** For CE compliant countries see errata sheet included with control panel.				
The design, material and specifications are subject to change without notice.				

CLEARANCES XPR-12CL/15CL/18CL

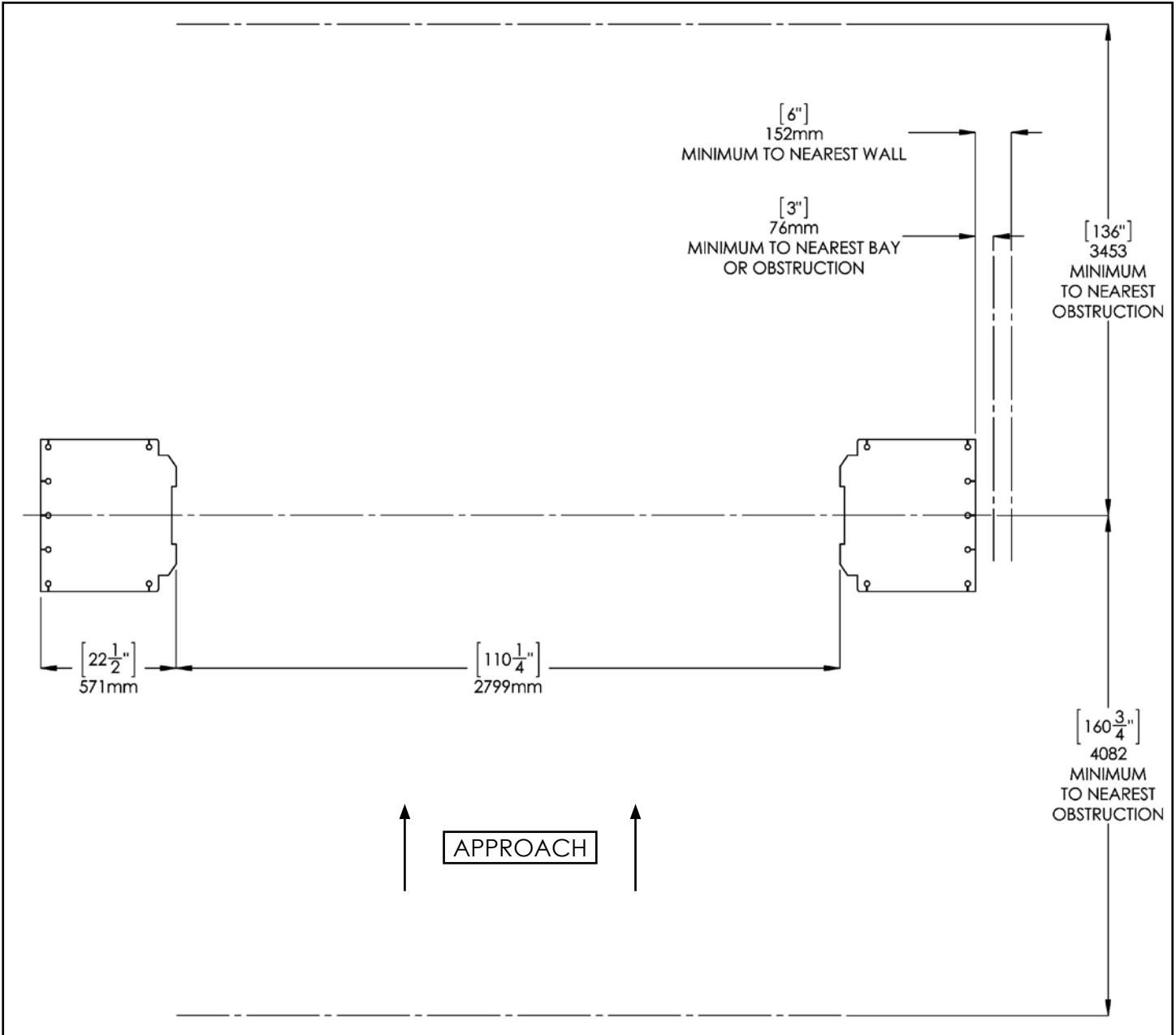

LIFT HEIGHT CLEARANCE NOTE: There must be a 1" MIN distance from top of lift to nearest obstruction.

STEP 3

(Column Preparation)

COMPLETE THE FOLLOWING PRIOR STANDING UP COLUMNS.

1. Slide Lift Head up Column to aid in Pulley removal and Equalizer Cable routing. (See Fig 3.1)

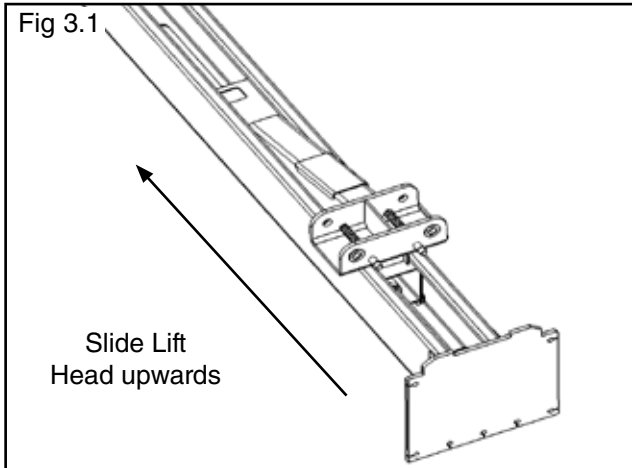

2. Temporarily remove the cable sheaves located at the inside bottom of each Column. (Fig. 3.2)

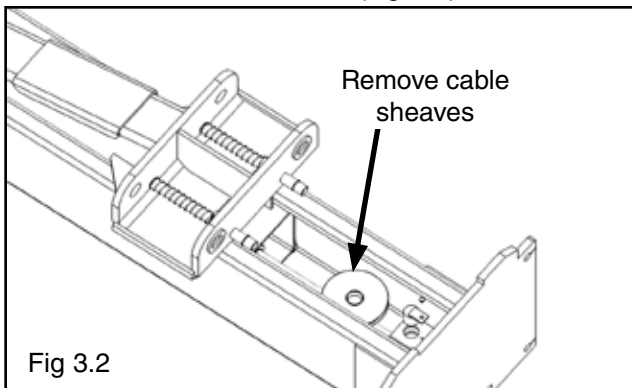

3. Route the button around the bottom sheave and secure at the carriage lock plate located inside each Lift Head. Route threaded end of cable upwards through the bottom of the carriage. Leave excess cable resting on top of carriage until further steps are required. (See Fig 3.3 and 3.4)

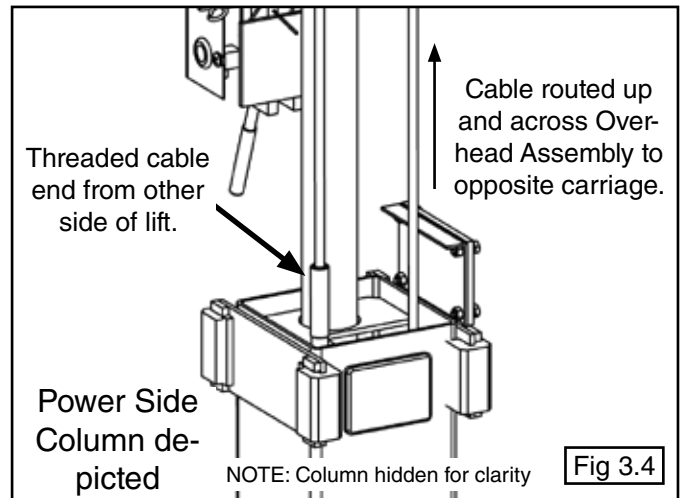
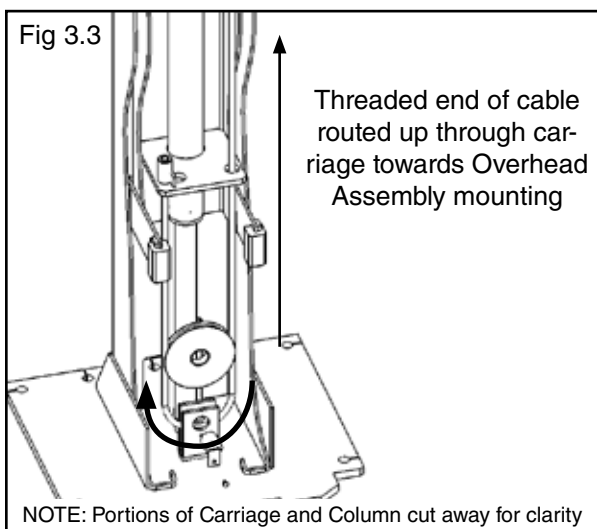

4. Install the straight and elbow Cylinder Fittings in Cylinder Ports. Pay attention when installing the elbow fittings to ensure that each fitting points towards the side of the Column that the hose retainer clips are located on. (See Fig 3.5)

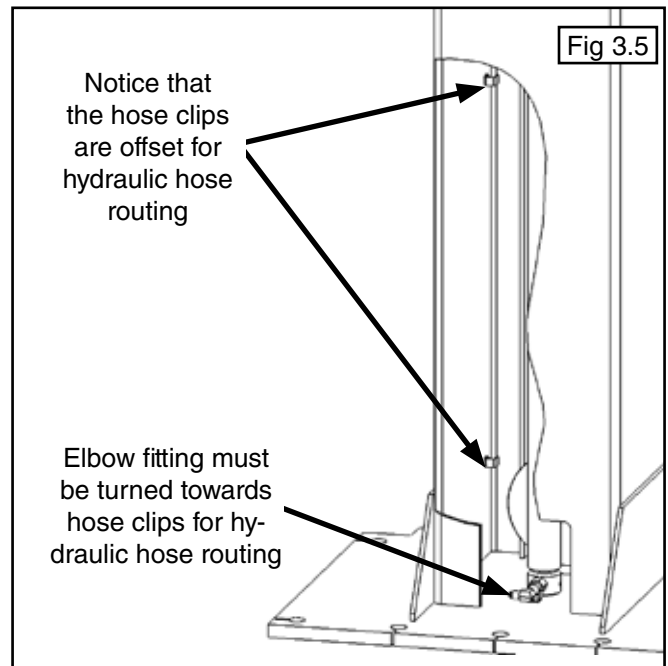

NOTE
FOR XPR-12CL/15CL/18CL-192 MODELS FIT EXTENSION WELDMENTS TO POST ASSEMBLY IN THIS STEP FOR EASE OF INSTALLATION AND BOLT TOGETHER AS SHOWN ON PAGE 13 WITH M10 HARDWARE.

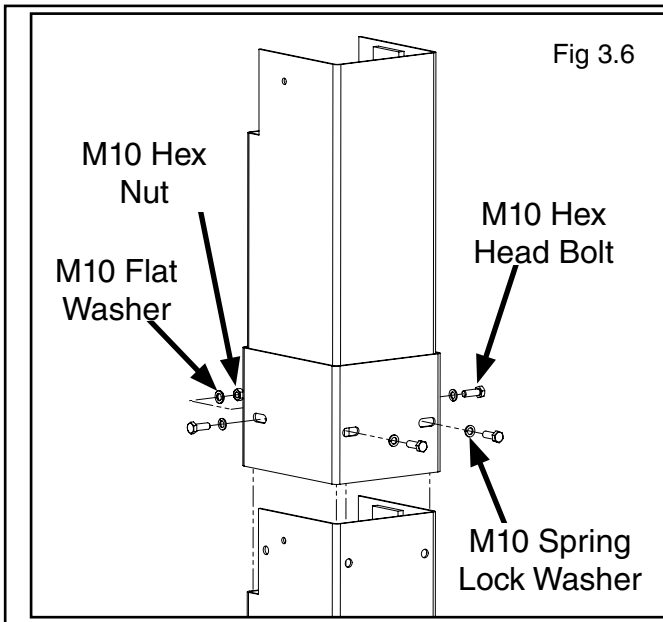

6. Route both Hoses in their respective Columns **PRIOR** to raising Columns to their vertical position. When routing the Hydraulic Hose through the Columns, make sure to route through the Retaining Clips welded inside each Column. Make sure that the Hose is clear of any moving parts. It may be necessary to tie Hose clear of obstructions by using nylon tie straps or wire. Refer to Step 10.



BE SURE TO ROUTE THE HYDRAULIC HOSES THROUGH THE RETAINING CLIPS WELDED INSIDE EACH COLUMN.

EQUALIZER CABLE ROUTING

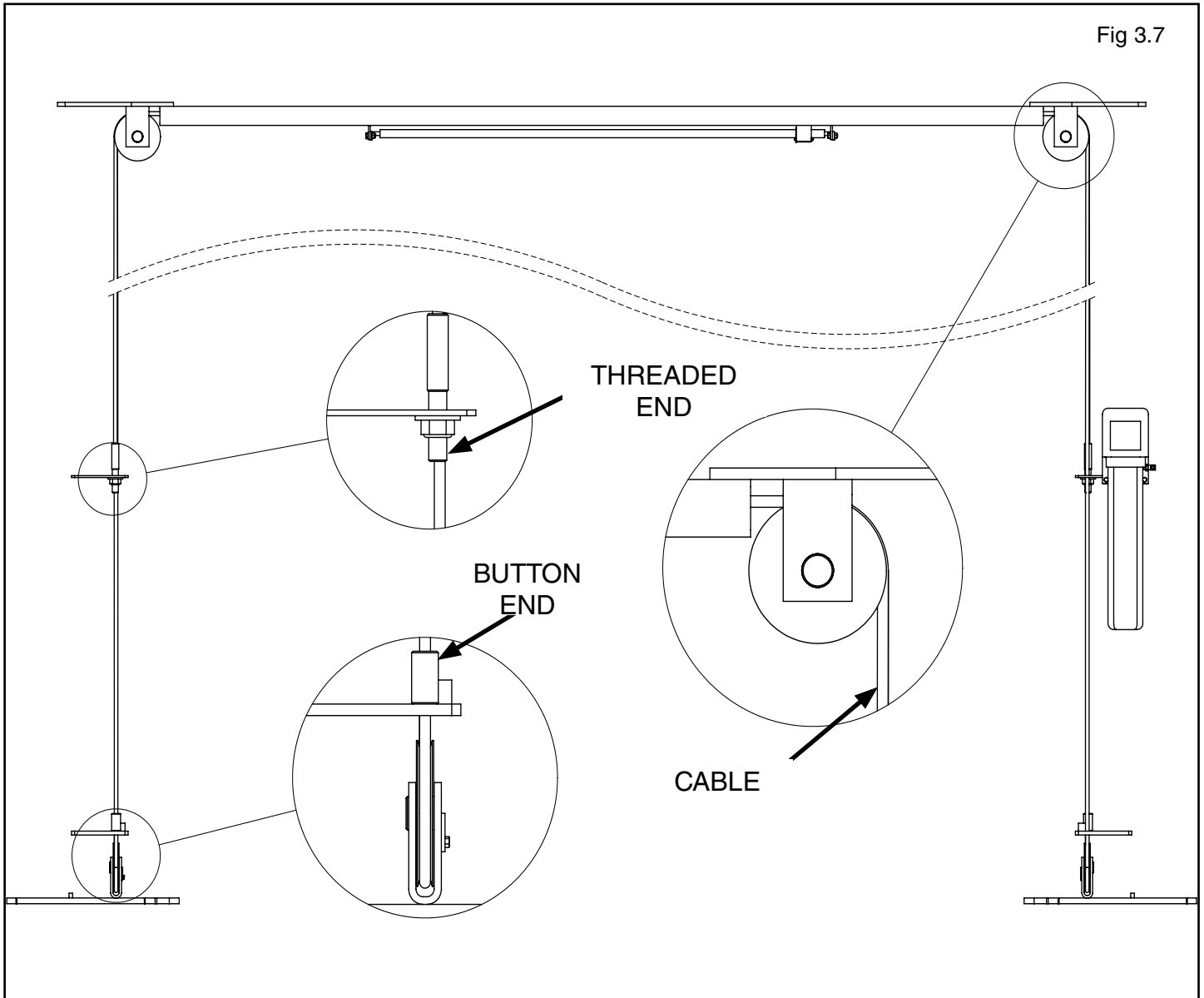

HOSE ROUTING

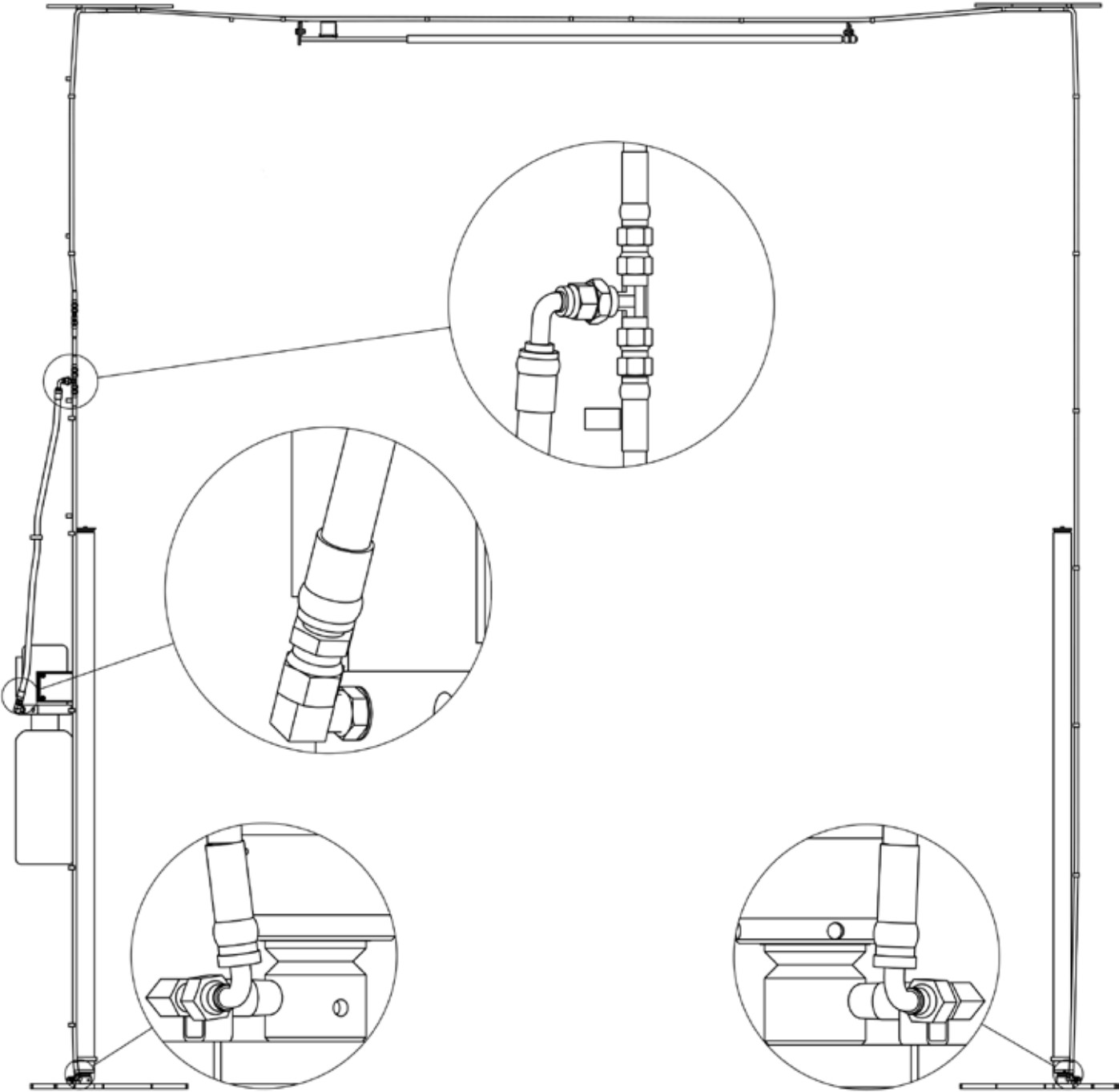

FLOOR PLAN

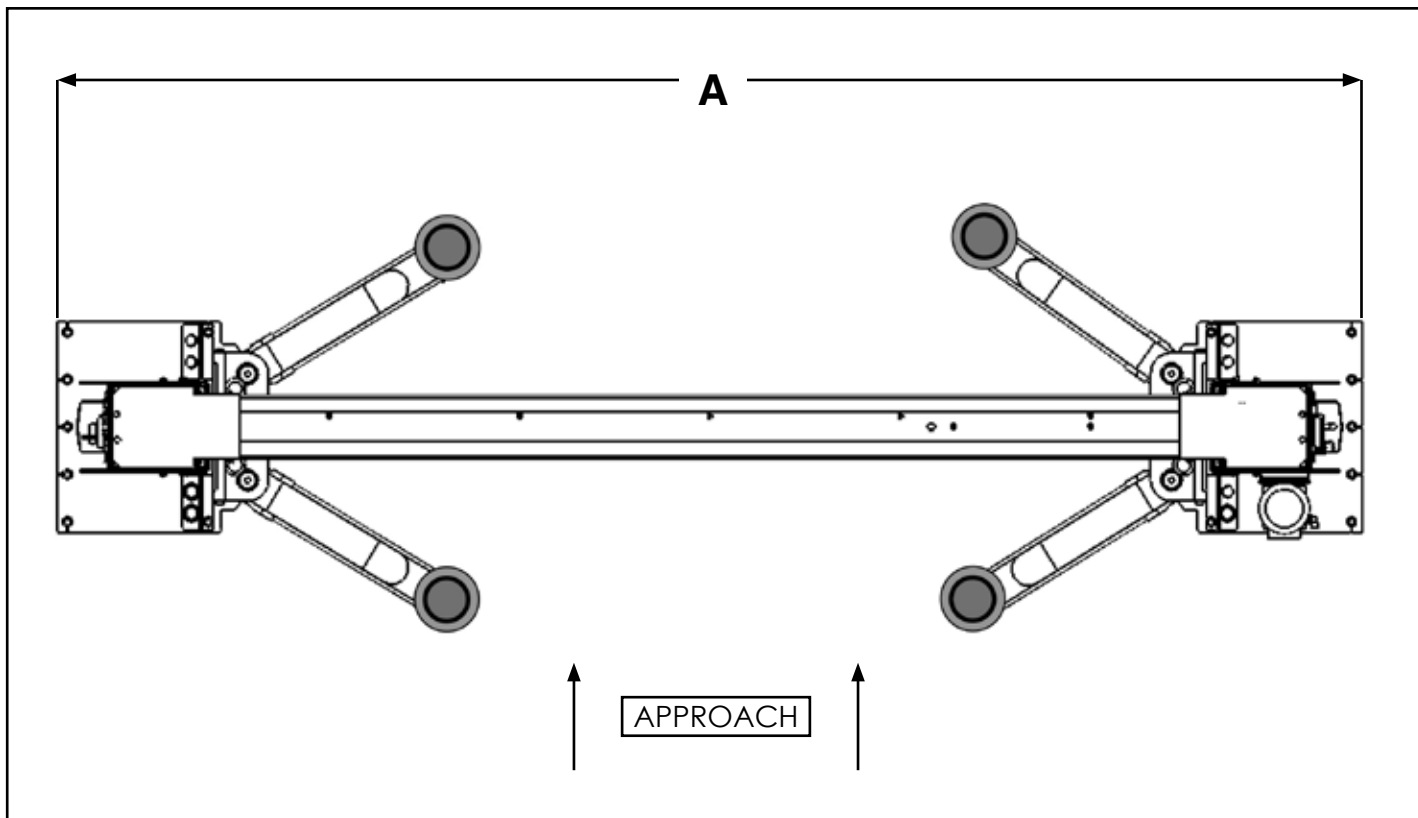

Model	A	Capacity
XPR-12CL	155" / 3937 mm	12,000 LBS
XPR-15CL	155" / 3937 mm	15,000 LBS
XPR-18CL	155" / 3937 mm	18,000 LBS

STEP 4

(Site Layout)

1. Determine which side of the lift will be the approach side.
2. Now determine where the power unit will be located. The POWER SIDE column has the power unit mounting bracket attached to the side.
3. Use the chart on page 13 to determine which lift width layout you would like to use.
4. Once a location is determined, use a carpenters chalk

line to layout an alignment line for the Column locations. Keep all dimensions square within 1/8" (3mm) or malfunctioning of the lift can occur. (See Fig 4.1)

5. After the Column locations are properly marked, use chalk or crayon to make an outline of the posts on the floor at each Column location using the Column base plates as a template.
6. **CHECK ALL DIMENSIONS TWICE** and make sure that the layout is perfectly square.



STEP 5

(Installing The POWERSIDE Column)

NOTE:

BENDPAK LIFTS ARE SUPPLIED WITH INSTALLATION INSTRUCTIONS AND CONCRETE FASTENERS MEETING THE CRITERIA AS PRESCRIBED BY THE AMERICAN NATIONAL STANDARD "AUTOMOTIVE LIFTS - SAFETY REQUIREMENTS FOR CONSTRUCTION, TESTING, AND VALIDATION" ANSI/ALI ALCTV-2011. LIFT BUYERS ARE RESPONSIBLE FOR ANY SPECIAL REGIONAL STRUCTURAL AND/OR SEISMIC ANCHORING REQUIREMENTS SPECIFIED BY ANY OTHER AGENCIES AND/OR CODES SUCH AS THE UNIFORM BUILDING CODE (UBC) AND/OR INTERNATIONAL BUILDING CODE (IBC).

1. Before proceeding, double the check measurements and make certain that the bases of each Column are aligned with the chalk line.
2. Using the base plate on the POWERSIDE column as a guide, drill each anchor hole in the concrete approximately 6" deep for 12K and 15K models and 8" for 18K models using a rotary hammer drill and 3/4" concrete drill-bit. To assure full holding power, do not ream the hole or allow the drill to wobble. (See Fig. 5.1)

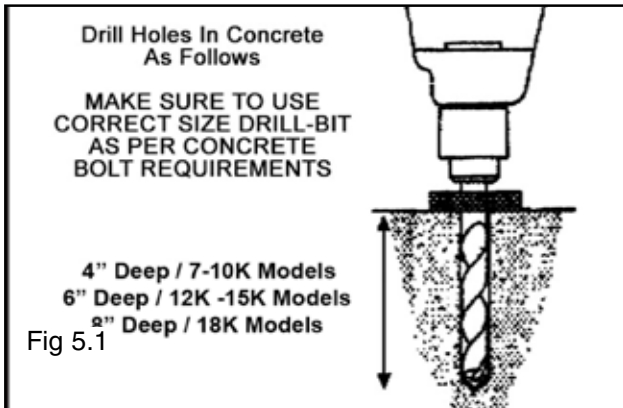

3. After drilling, remove dust thoroughly from each hole making certain that the Column remains aligned with the chalk line.
4. Assemble the washers and nuts on the anchors then tap into each hole with a hammer until the washer rests against the Base Plate. Be sure that if shimming is required that enough threads are left exposed. (See Fig. 5.2)

Fig 5.2

Tap anchor bolts into each hole with a hammer until the washer rests against the baseplate.



5. Insert the shims as necessary under the Base Plate so that when the anchor bolts are tightened, the Columns will be plumb. (See Fig. 5.3)

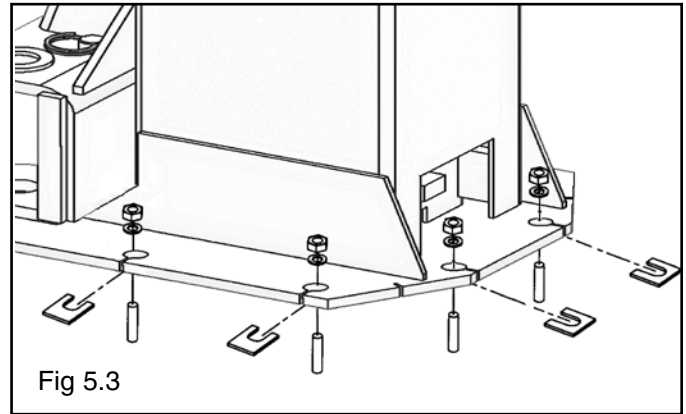

NOTE:

TO EASE INSTALLATION OF THE OVERHEAD ASSEMBLY, IT HELPS TO KEEP THE ANCHOR BOLTS LOOSE ON ONE OF THE POSTS UNTIL THE OVERHEAD ASSEMBLY IS MOUNTED.

6. With the shims and anchor bolts in place, tighten by securing the nut to the base then turning 3-5 full turns clockwise. **DO NOT** use an impact wrench for this procedure. (See Fig. 5.4)

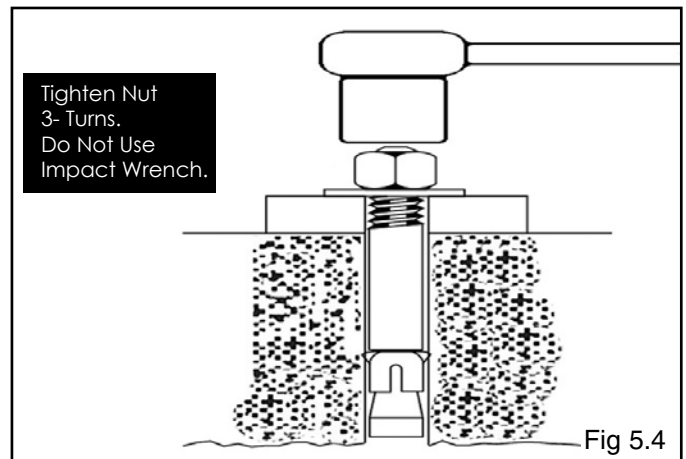

STEP 6

(Mounting The OFFSIDE Column)

1. Position the OFFSIDE Column at the designated chalk locations and secure to the floor following the same procedures as outlined in STEP FIVE; Items 1-6.

NOTE:

TO EASE THE INSTALLATION OF THE OVERHEAD ASSEMBLY, IT HELPS TO KEEP THE ANCHOR BOLTS LOOSE ON ONE OF THE POSTS UNTIL THE OVERHEAD ASSEMBLY IS MOUNTED.

STEP 7

(Mounting the Overhead Assembly)

NOTE:

IN ORDER TO ROUTE THE EQUALIZER CABLES THE SHEAVES MUST BE REMOVED.

1. Remove all of the Equalizer pulleys in preparation of installing the Overhead Assembly.
2. Using a lifting device, raise the Overhead Assembly into position on top of the Columns. Bolt to the columns using the 10 mm Hex Bolts, Nuts and Washers.
3. **YOU MUST POSITION THE SWITCH ENCLOSURE ADJACENT POWERSIDE COLUMN.** (See Fig. 7.1)

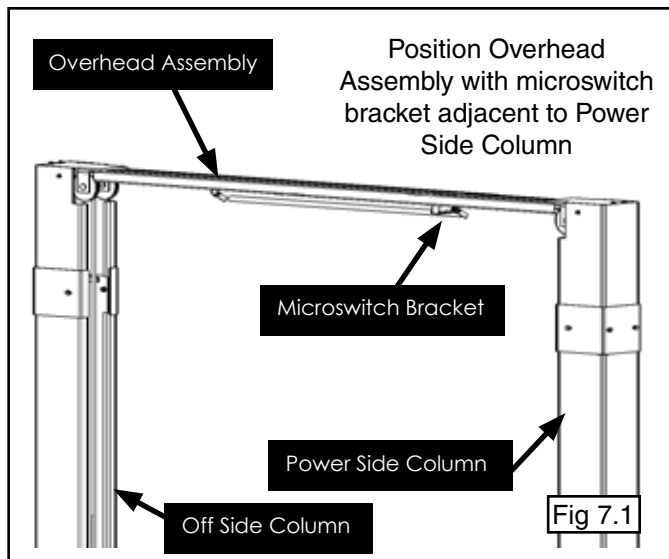

4. Tighten the Overhead Assembly Bolts.



IF THE ANCHOR BOLTS WERE LOOSENEED TO AID ON THE INSTALLATION OF THE TOP TROUGH, TIGHTEN ANCHOR BOLTS AS INDICATED IN STEP 5 ITEMS 4 - 7.

STEP 8

(Mounting the Hydraulic Power Unit)

1. Attach the power unit to the POWER SIDE Column. Install the vibration dampener between the power unit and the power unit mounting plate on the Power Side Column, using four M8 hex head bolts and nuts supplied. (See Fig 8.1)

2. **Fill the reservoir with 10 WT. HYDRAULIC OIL OR DEXRON ATF**, approximately four gallons. Make sure the

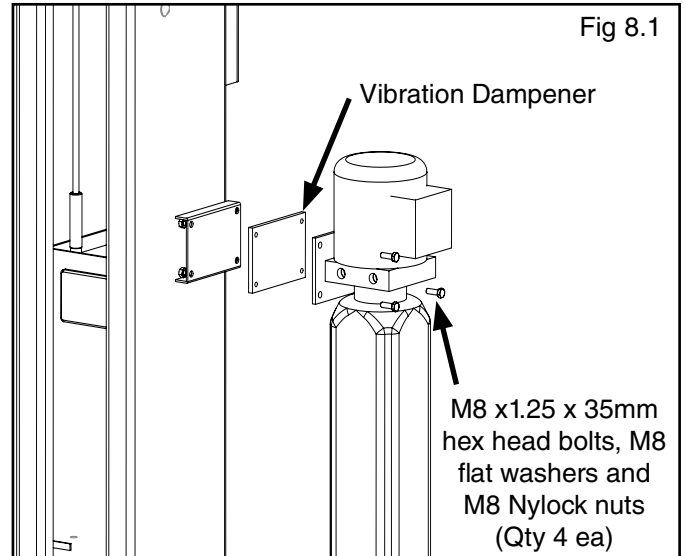

funnel used to fill the Power Unit and unit is clean. Do not connect power unit hydraulic hose assembly at this time.

3. The standard power unit for your lift is 220 volt, 60HZ, single phase. All wiring must be performed by a certified electrician only. SEE WIRING INSTRUCTIONS AFFIXED TO MOTOR FOR PROPER WIRING INSTRUCTIONS.



ALL WIRING MUST BE PERFORMED BY A LICENSED ELECTRICIAN.



DO NOT PERFORM ANY MAINTENANCE OR INSTALLATION OF ANY COMPONENTS WITHOUT FIRST ENSURING THAT ELECTRICAL POWER HAS BEEN DISCONNECTED AT THE SOURCE OR PANEL AND CANNOT BE RE-ENERGIZED UNTIL ALL MAINTENANCE AND/OR INSTALLATION PROCEDURES ARE COMPLETED.



WARNING

DO NOT RUN POWER UNIT WITHOUT OIL. DAMAGE TO POWER UNIT PUMP CAN OCCUR. THE POWER UNIT MUST BE KEPT DRY. DAMAGE TO POWER UNIT CAUSED BY WATER OR OTHER LIQUIDS SUCH AS DETERGENTS, ACID ETC., IS NOT COVERED UNDER WARRANTY. OPERATE LIFT ONLY BETWEEN TEMPERATURES OF 41 °- 104° F.

ANY IMPROPER ELECTRICAL INSTALLATION MAY DAMAGE POWER UNIT MOTOR AND RESULTING DAMAGE WILL NOT BE COVERED UNDER WARRANTY. MOTOR CAN NOT RUN ON 50HZ WITHOUT A PHYSICAL CHANGE IN MOTOR.

USE A SEPARATE CIRCUIT BREAKER FOR EACH POWER UNIT. PROTECT EACH CIRCUIT WITH TIME DELAY FUSE OR CIRCUIT BREAKER.

FOR 208-230 VOLT, SINGLE PHASE, USE A 25 AMP FUSE.

FOR 208-230 VOLT, THREE PHASE, USE A 20 AMP FUSE.

FOR 380-440 VOLT, THREE PHASE, USE A 15 AMP FUSE.

STEP 9

(Installing the Safeties and Safety Cable)

1. Install safety weldments on to each respective Column. (See Figs 9.1 - 9.2)

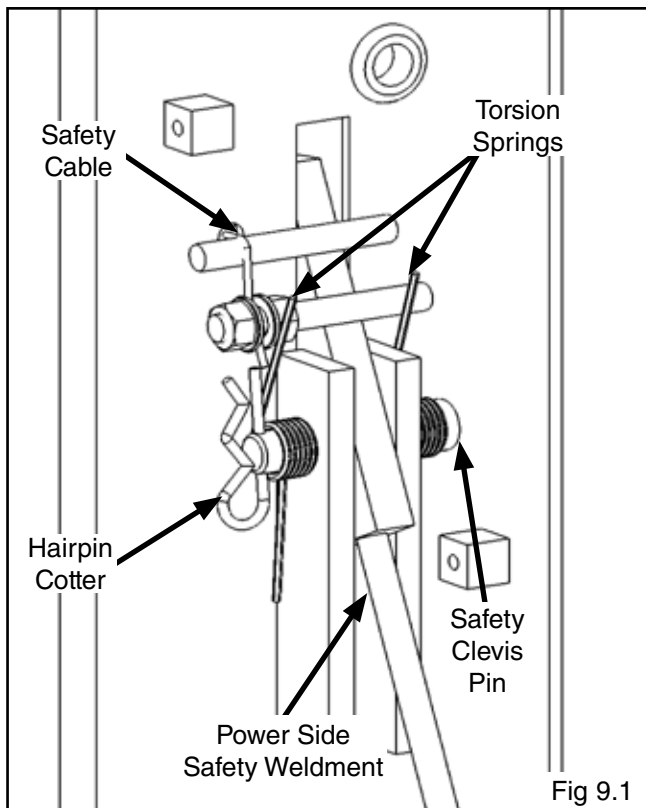

2. From the Off Side Column insert the non-looped end of the safety cable through the hole located to the right of the Off Side safety weldment. (See Fig 9.3)
3. Route the cable under the sheave and route it towards the Overhead Assembly. (See Fig 9.4)
4. Route the cable through the Overhead Assembly's safety sheave(s) and across the lift. (See Figs 9.5 - 9.6)

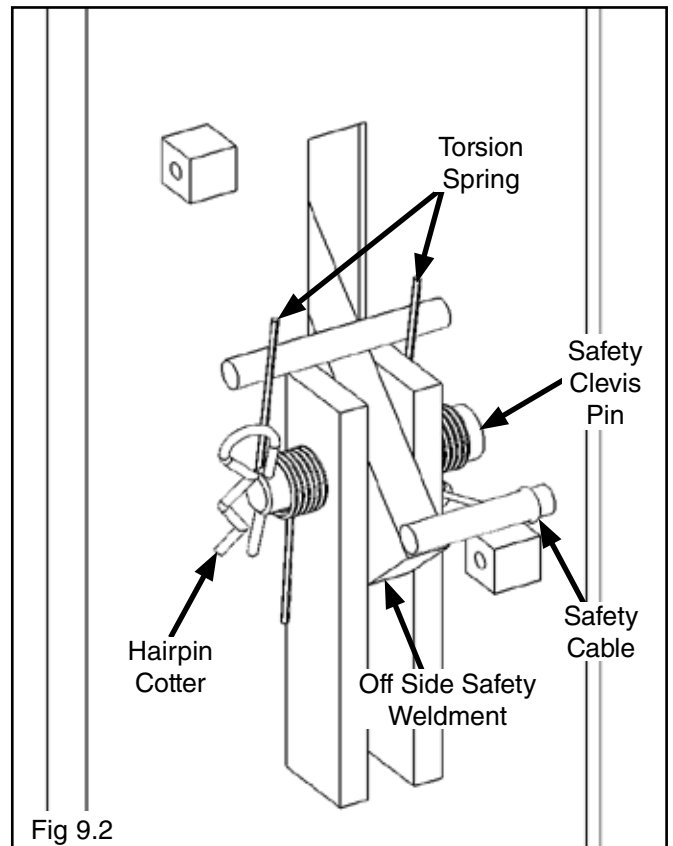

5. Route the cable the same way on the Power Side going back down the Column.
6. Route the cable over the top pin on the safety handle. Insert the cable end through the hole on the threaded pin. (See Fig 9.7)
7. Pull the slack out the safety cable and keep tension on the cable as nuts are being tightened. Tighten jam nuts on either side of the cable keeping the cable centered to the hole to secure it into place. (See Fig 9.7)

! DANGER

ENSURE THAT BOTH THE POWER SIDE & OFF SIDE SAFETIES ENGAGE PROPERLY PRIOR TO LIFT OPERATION.

NOTE:
MAKE SURE TO KEEP THE SAFETY CABLE CENTERED WHEN TIGHTENING JAM NUTS ON SAFETY.

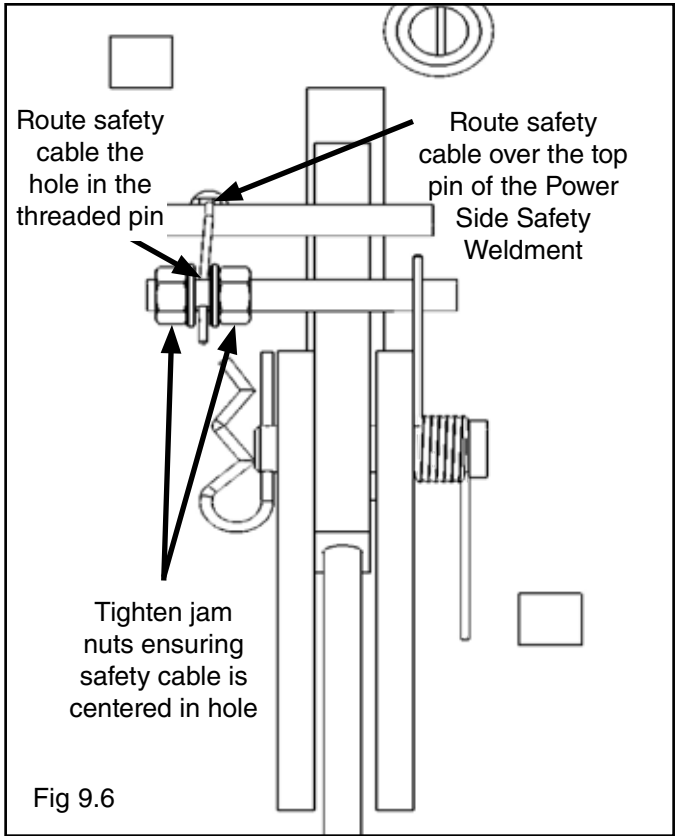
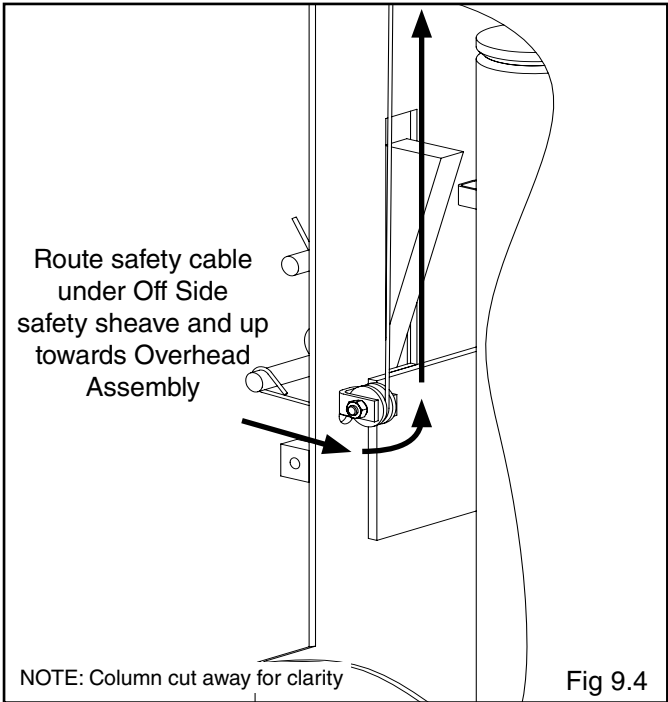
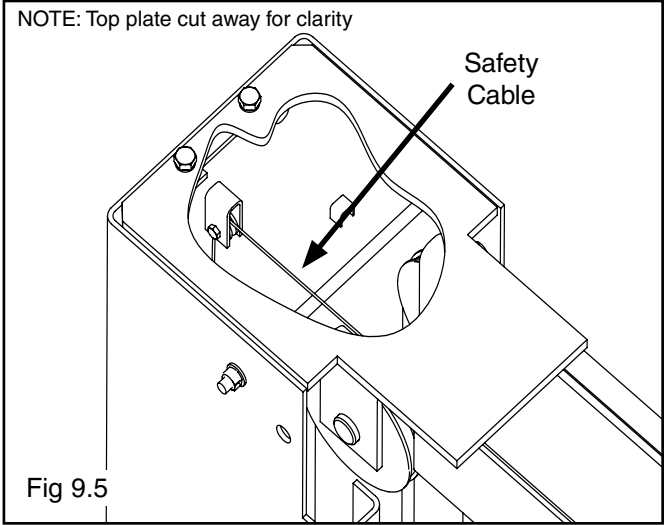
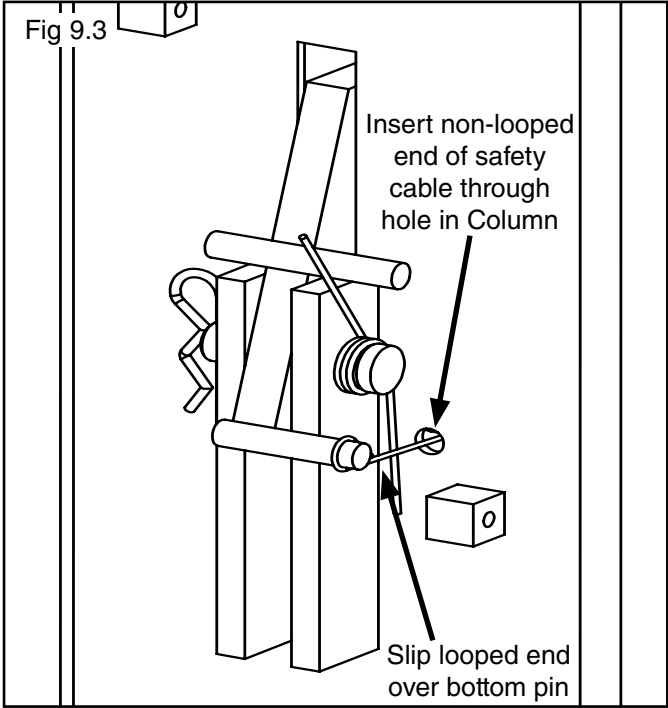

STEP 10

(Installing Hydraulic Lines)

1. Install the bulkhead tee fitting into the Power Side Column. The through hole is located approximately 90 inches from the floor on the back wall of the Power Side Column.
2. Connect the **Power Side** cylinder hose to the tee fitting. Be sure to route the hose through the retainer clips inside the posts.
3. Route the Off Side cylinder hose (Crossover Hose) up through the Column and across the Overhead Assembly, down the Column and connect it to the bulkhead tee fitting. (See Fig 10.1)

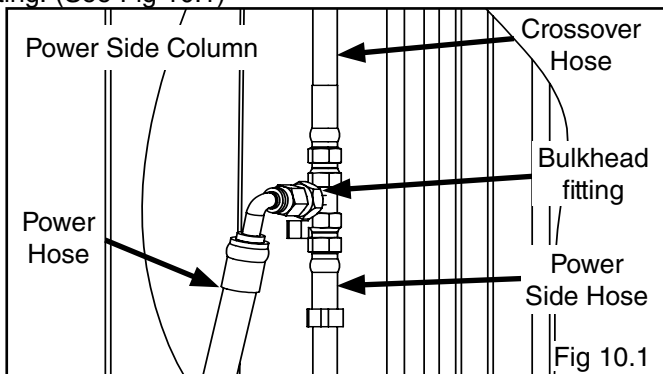

WARNING

WHEN ROUTING THE HYDRAULIC HOSE THROUGH THE POSTS, MAKE SURE TO ROUTE THROUGH THE HOSE CLIPS WELDED INSIDE EACH POST. MAKE SURE THAT THE HOSE IS CLEAR OF ANY MOVING PARTS. IT MAY BE NECESSARY TO TIE THE HOSE CLEAR BY USING NYLON TIE STRAPS OR WIRE.

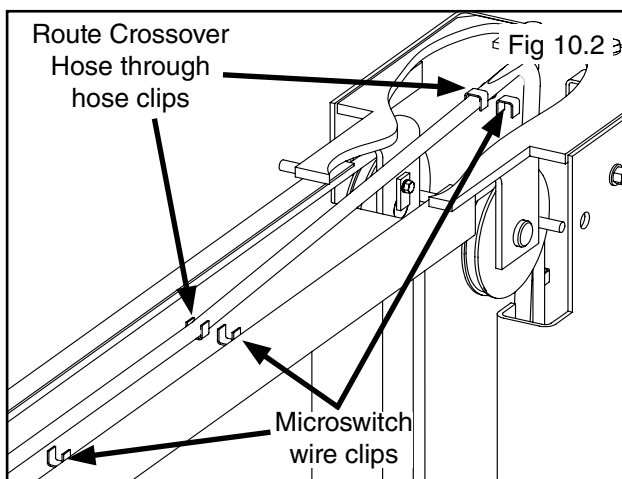

STEP 11

WARNING

WHEN THE CABLE ADJUSTING NUTS BOTTOM OUT ON THE THREADED END OF THE CABLE CONNECTOR AND THERE IS STILL SLACK IN THE CABLES, THE CABLES HAVE STRETCHED BEYOND THE SAFE USEFUL LENGTH AND NEED TO BE REPLACED WITH FACTORY APPROVED CABLE ASSEMBLIES. DO NOT PLACE WASHERS, SPACERS OR OTHER DEVICES TO "SHORTEN" THE EFFECTIVE CABLE LENGTH AS DAMAGE TO THE LIFT OR INJURY TO PERSONS MAY OCCUR.

(Routing the Equalizer Cables)

Refer to illustrations on Page 11.

1. Raise and lock each Carriage approximately 28" above the ground. (See Fig. 11.1)

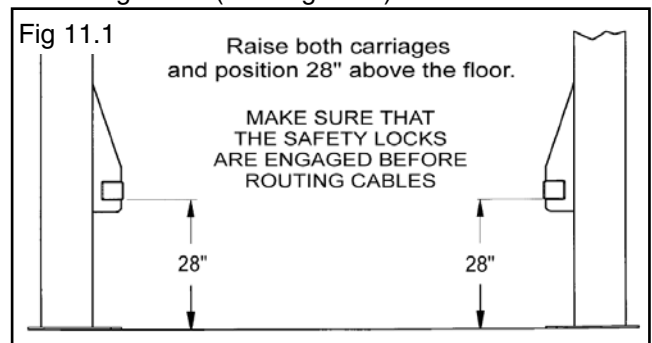

DANGER

MAKE SURE THAT THE SAFETY LOCKS ON EACH POST ARE FULLY ENGAGED BEFORE ATTEMPTING TO ROUTE EQUALIZER CABLES AND/OR HOSES. CARRIAGES MUST BE EQUAL HEIGHT FROM THE FLOOR BEFORE PROCEEDING.

2. With the Carriages locked at 28" off the floor, route the Equalizer Cables up to the Top Trough.
3. Route the cables through the sheave brackets and reinstall the sheaves. (See Fig. 11.2)

Note: The sheaves should have been removed in Step 6.

4. Insert the threaded end of the cable through the hole on top of the carriage. Place M22 washer and M22 Nylock nut on threaded cable end. Tighten cable nuts until taut, checking that both cables have equal tension. (See Fig 11.3)

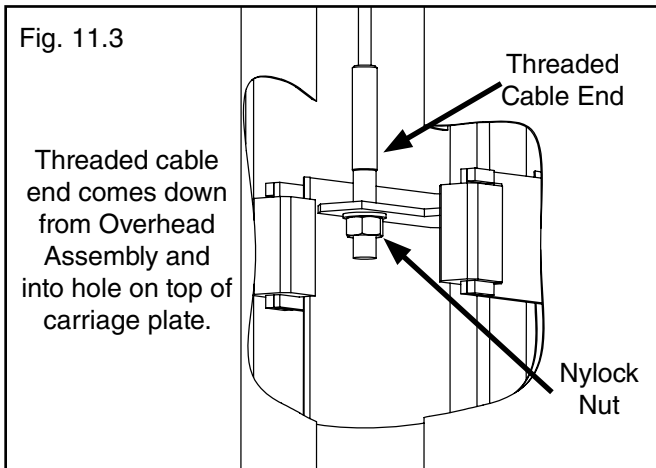
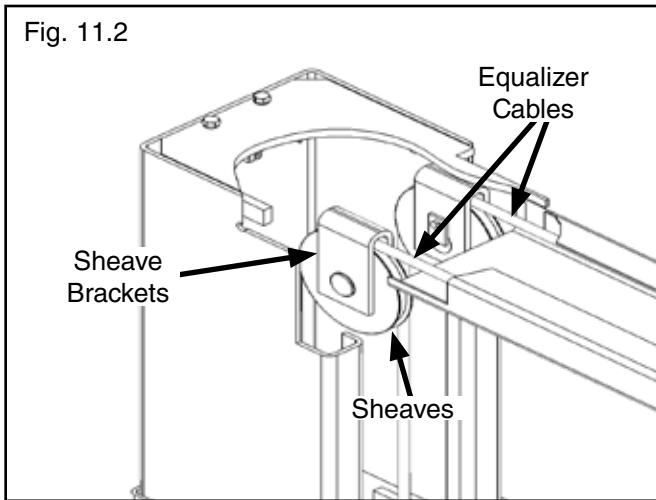

⚠ DANGER

ALL WIRING MUST BE PERFORMED BY A LICENSED ELECTRICIAN.

⚠ DANGER



DO NOT PERFORM ANY MAINTENANCE OR INSTALLATION OF ANY COMPONENTS WITHOUT FIRST ENSURING THAT ELECTRICAL POWER HAS BEEN DISCONNECTED AT THE SOURCE OR AT POWER PANEL AND CANNOT BE RE-ENERGIZED UNTIL ALL MAINTENANCE AND/OR INSTALLATION PROCEDURES ARE COMPLETED.

STEP 12
(Installing Overhead Micro Switch)

⚠ CAUTION

MICROSWITCH WIRE MUST BE RUN THROUGH CLIPS IN POST AND OVERHEAD ASSEMBLY. FAILURE TO DO SO CAN CAUSE DAMAGE TO LIFT OR TO VEHICLES.

1. Install the overhead Microswitch as shown below. Be sure to keep wire clear of moving parts. (See Fig.12.1)

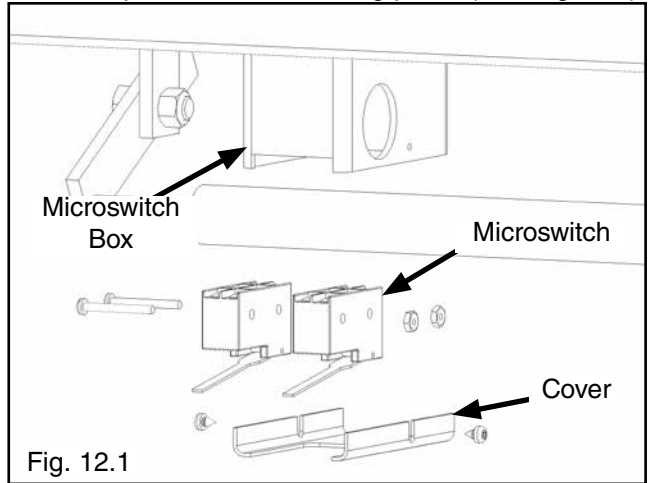

Note: Second Microswitch for 3 phase wired units ONLY. 3 phase Microswitch Kit can be found in the Power Unit shipping box.

2. Route Microswitch wire through the hole in Power Side Column with rubber grommet. Loosely position Power Side safety cover and run other end of Microswitch wire through hole with grommet in Power Side safety cover. (See Fig. 12.2)

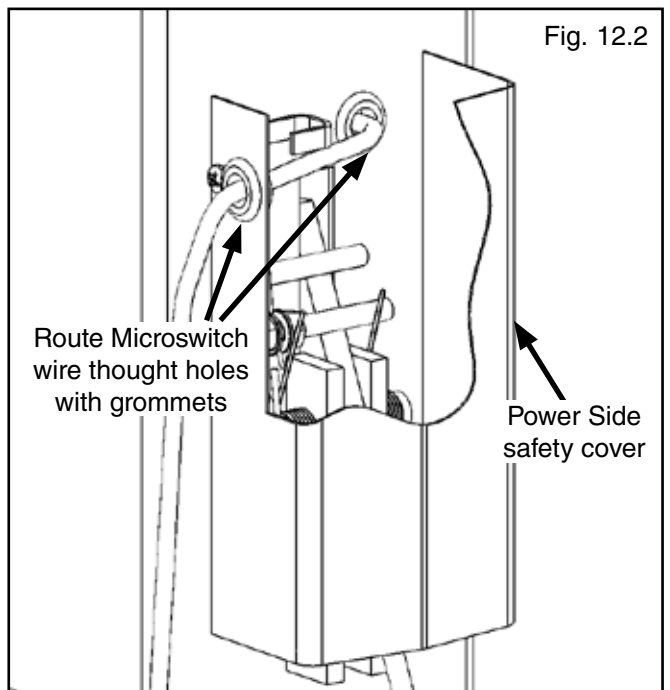

3. Route wire up through Column and across Overhead Assembly through hole in Overhead Assembly into the Microswitch box. (See Fig. 12.3)

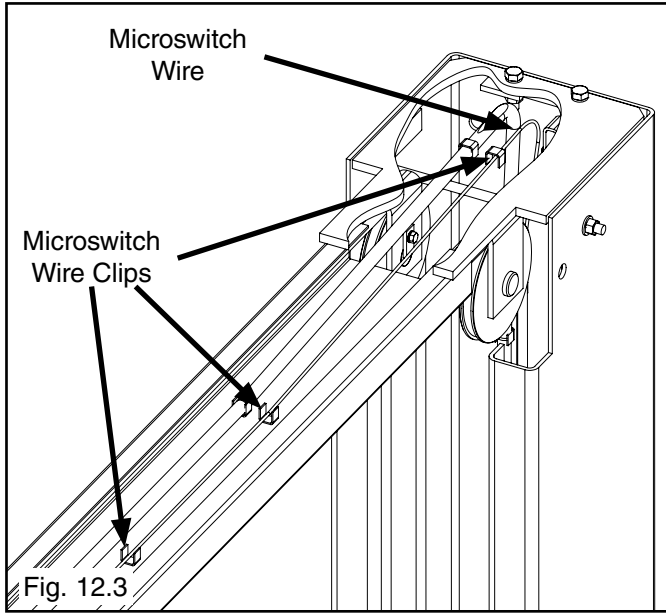

2. Install the 90° fitting w/ O-ring into the power port of the power unit. Use teflon tape on the pipe fittings ONLY. Connect power unit hose assembly to the 90° w/O-ring fitting on power unit. (See Fig. 13.2)

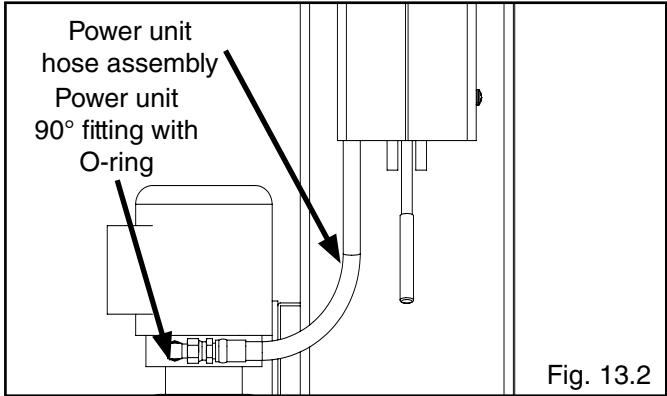

3. Connect other end of power unit hydraulic hose assembly to the bulkhead fitting. (See Fig. 13.3)

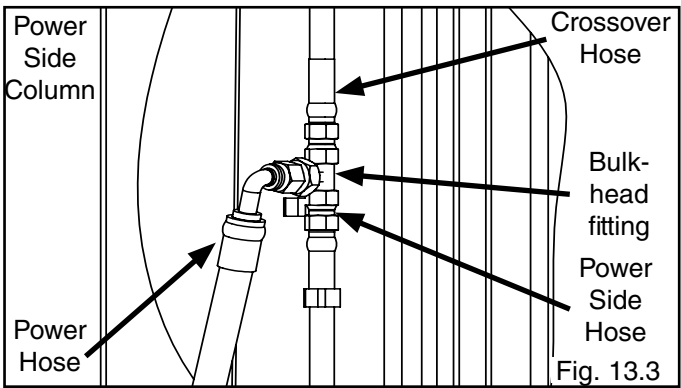

STEP 13
(Installing power unit hose assembly and Power Side safety cover)



POWER UNIT HYDRAULIC HOSE MUST BE ROUTED THROUGH THE HOSE CLIPS IN POWER SIDE SAFETY COVER. FAILURE TO DO SO CAN RESULT IN PERSONAL INJURY OR DAMAGE TO THE LIFT.

1. With Power Side safety cover loosely positioned route power unit hydraulic hose through clips in Power Side safety cover. (See Fig. 13.1)

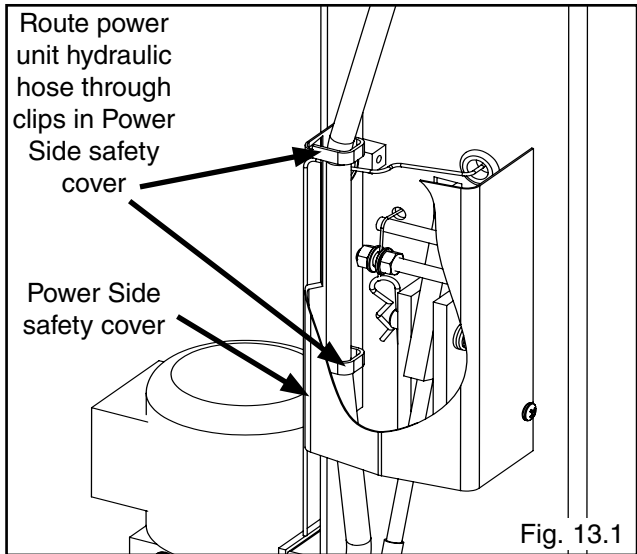

4. After safeties have been adjusted and checked for proper operation, install and tighten Power Side safety cover and Off Side safety cover mounting screws. (See Fig. 13.4 and 13.5)

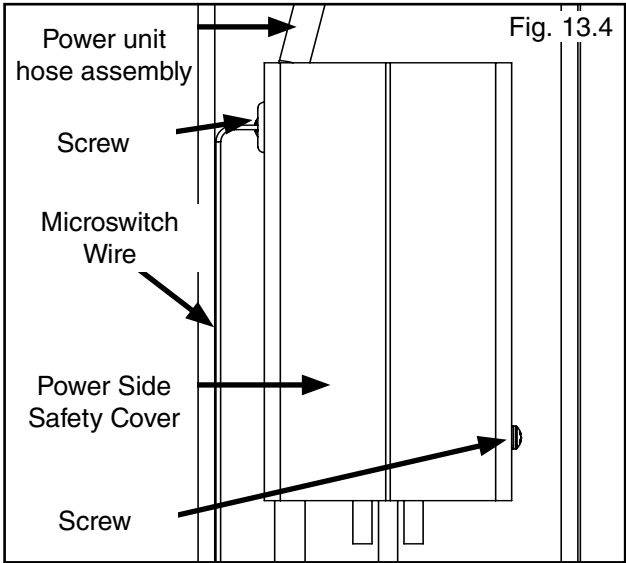

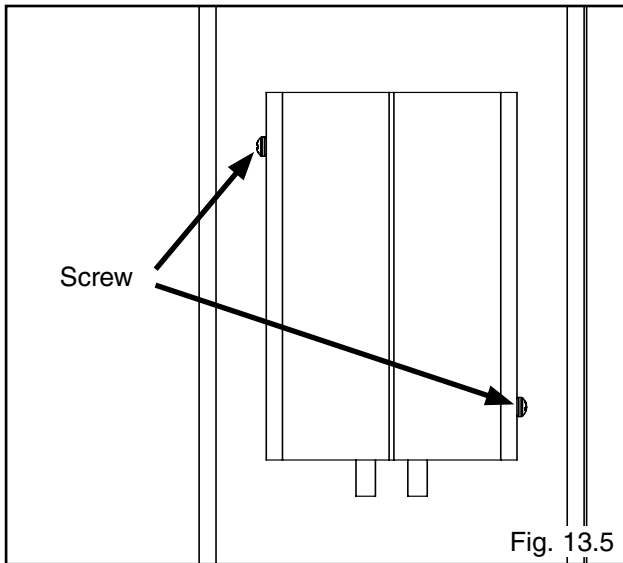

Fig. 13.5

STEP 14 (Installing the Lift Arms)

1. Place the lift arm assemblies in the lift heads.
2. Install the lift head pins into the lift head and through the holes in the arm assembly. (See Fig. 14.1)

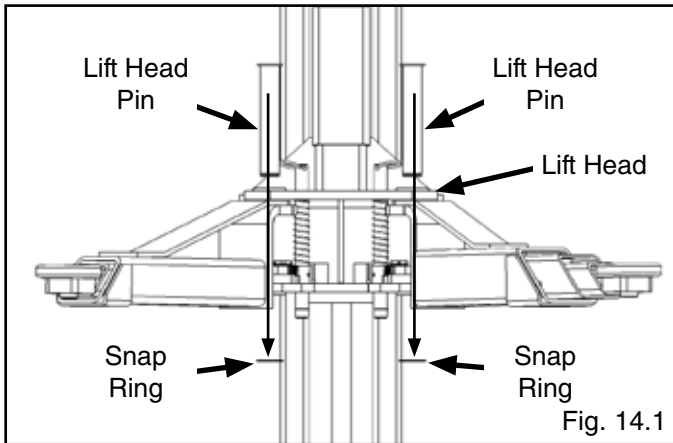

Fig. 14.1

3. Install the snap ring into the groove in the lift head pin on under side of the lift head. (See Fig. 14.2)

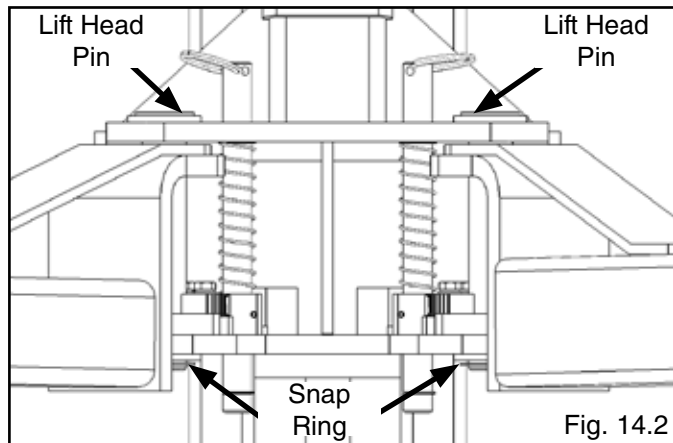

Fig. 14.2



THE ARM RESTRAINT GEARS MUST BE POSITIONED PROPERLY. CONFIRMATION OF PROPER GEAR ENGAGEMENT MUST BE MADE PRIOR TO THE OPERATION OF THE LIFT. PERIODIC INSPECTION IS REQUIRED. FAILURE TO INSPECT THE ARM RESTRAINT GEARS ON ALL FOUR ARMS PROPERLY CAN RESULT IN DAMAGE TO THE VEHICLE OR INJURY AND/OR DEATH.

4. Place each Gear Ring against the Lift Head Pin and align the holes in the Gear Ring with the threaded holes in the Arm Ears. Ensure that the teeth on the Gear Ring mesh smoothly with the teeth on the gears of the Lift Head. (See Fig. 14.3)

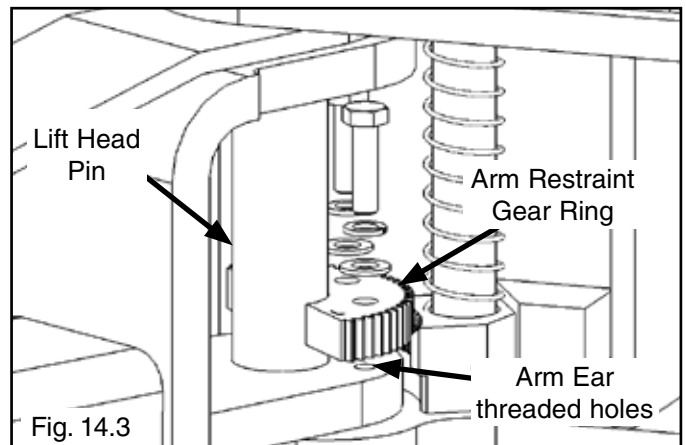

Fig. 14.3

5. Verify the operation of the arm restraints by pulling up on the key ring of the arm restraint pin. Pivot the arms back and forth and test the operation of the arm restraint pin in various positions. (See Fig. 14.4)

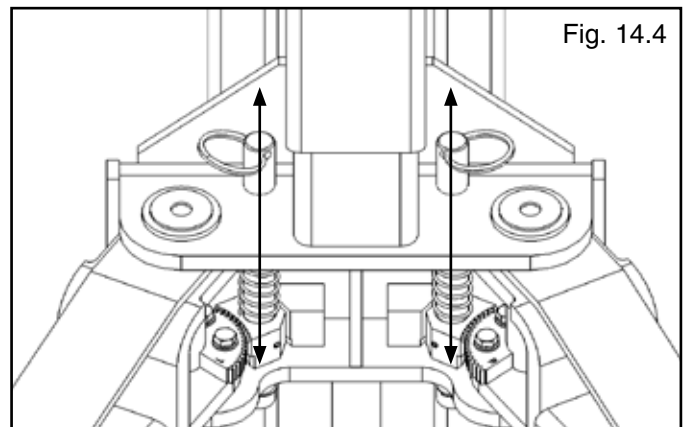

Fig. 14.4

6. Ensure that the arms do not move when a force of approximately 100 pounds or less is applied laterally to the fully extended arms.

! DANGER

NOTE:
EACH ARM RESTRAINT ASSEMBLY MUST BE INSPECTED BEFORE EACH AND EVERY TIME THE LIFT IS OPERATED.

DO NOT OPERATE THE LIFT IF ANY OF THE FOUR ARM RESTRAINT SYSTEMS ARE NOT FUNCTIONING PROPERLY.

REPLACE ANY BROKEN COMPONENTS OR COMPONENTS WITH BROKEN TEETH ONLY WITH AUTHORIZED OR APPROVED REPLACEMENT PARTS.

! WARNING

IMPORTANT LEVELING INSTRUCTIONS

Before operating your lift, check to make sure that both "A" and "B" measurements are EQUAL.

The lift arms must be level before operation.

If your lift arms are not level, shim the columns as required.

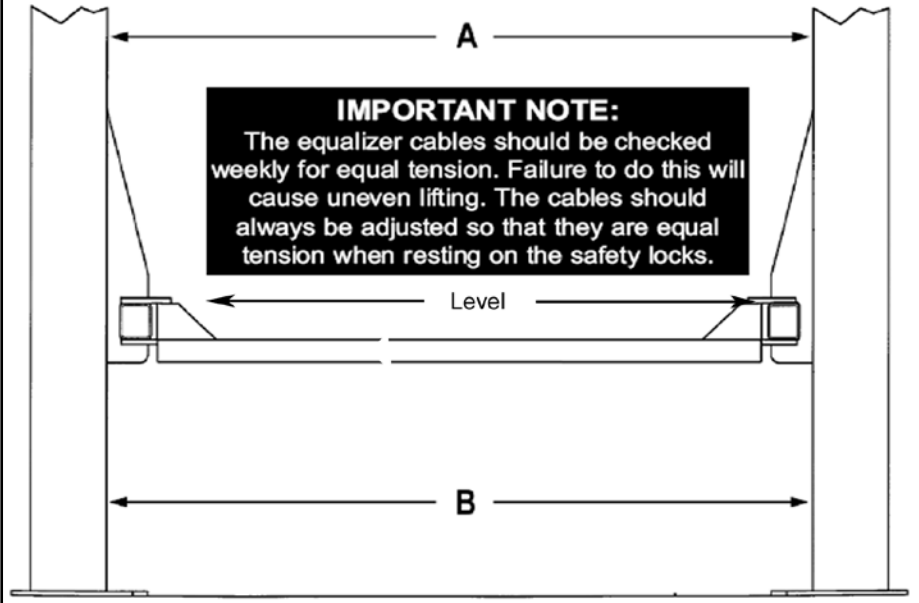

CARRIAGE STOP BOLT INSTALLATION



YOU MUST RE-INSTALL TOP CARRIAGE-STOP BOLT (SHOWN BELOW). TIGHTEN CARRIAGE-STOP BOLT TO 2-3 FT.-LBS. OF TORQUE UPON FINAL INSTALLATION INSPECTION.

THESE INSTRUCTIONS MUST BE FOLLOWED TO ENSURE PROPER INSTALLATION AND OPERATION OF YOUR LIFT. FAILURE TO COMPLY WITH THESE INSTRUCTIONS CAN RESULT IN SERIOUS BODILY INJURY AND/OR DEATH AND/OR VOID PRODUCT WARRANTY. MANUFACTURER WILL ASSUME NO LIABILITY FOR LOSS OR DAMAGE OF ANY KIND, EXPRESSED OR IMPLIED RESULTING FROM IMPROPER INSTALLATION OR USE OF THIS PRODUCT.

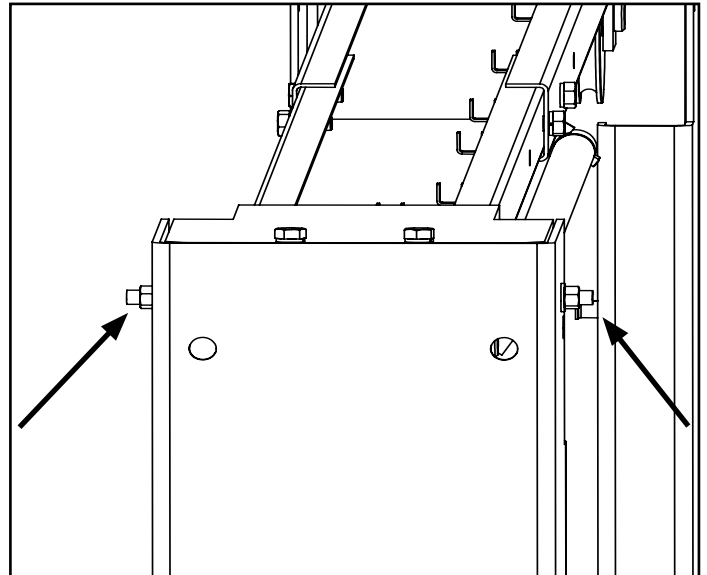
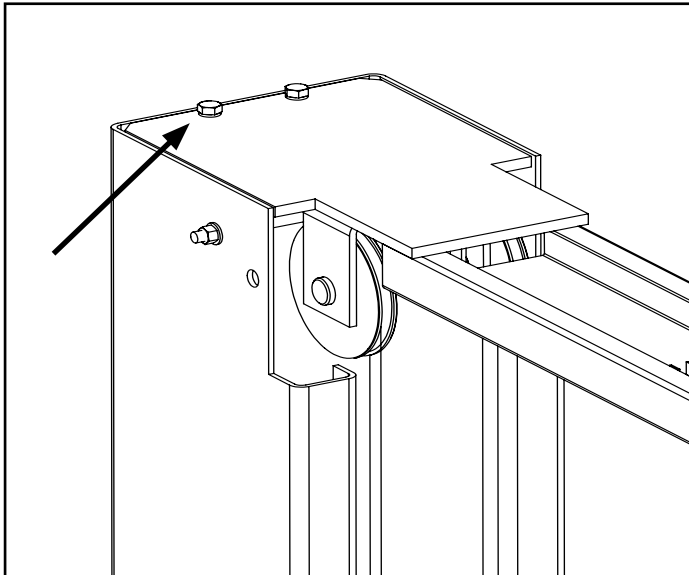



DO NOT PERFORM ANY MAINTENANCE OR INSTALLATION OF ANY COMPONENTS WITHOUT FIRST ENSURING THAT ELECTRICAL POWER HAS BEEN DISCONNECTED AT THE SOURCE OR PANEL AND CANNOT BE RE-ENERGIZED UNTIL ALL MAINTENANCE AND/OR INSTALLATION PROCEDURES ARE COMPLETED.



IMPORTANT POWER-UNIT INSTALLATION NOTES

- DO NOT run Power Unit with no oil. Damage to pump can occur.
- The Power Unit must be kept dry. Damage to Power Unit caused by water or other liquids such as detergents, acid etc., is not covered under warranty.
- Improper electrical hook-up can damage motor and will not be covered under warranty.
- Motor can not run on 50HZ without a physical change in motor.
- Use a separate breaker for each power unit.
- Protect each circuit with time delay fuse or circuit breaker.
- For 208-230 volt, single phase, use a 25 amp fuse.
- For 208-230 volt, three phase, use a 20 amp fuse.
- For 380-440 volt, three phase, use a 15 amp fuse.

Installation and adjustment.

DO NOT attempt to raise vehicle until a thorough operation check has been completed.

ALL WIRING MUST BE PERFORMED BY A CERTIFIED ELECTRICIAN ONLY.

Single Phase

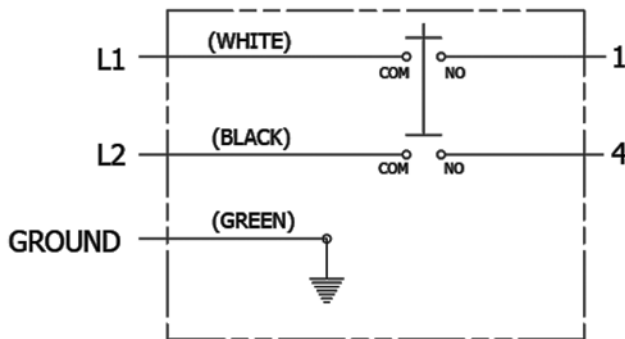

Three Phase

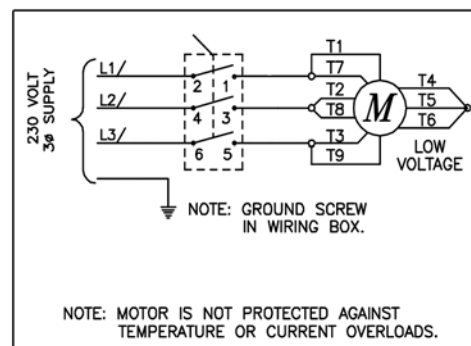

SEE WIRING INSTRUCTIONS AFFIXED TO MOTOR FOR PROPER WIRING INSTRUCTIONS.

WIRING DIAGRAM
 Overhead Microswitch
 220V Single Phase
 XPR TWO POST
 06-26-09

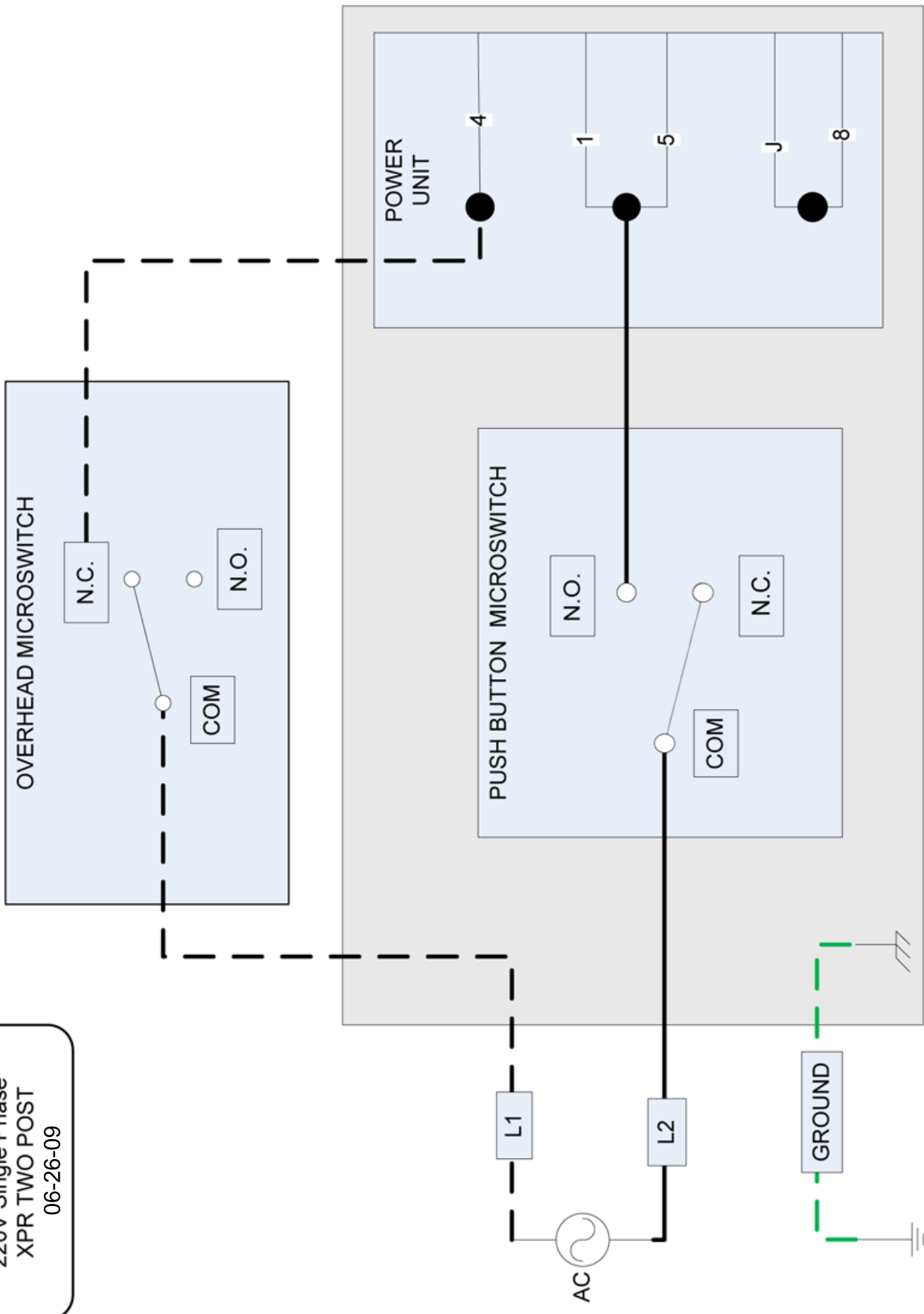

STEP 15 (Power Unit Connection)

1. Have a certified electrician run the power supply to motor. Refer to the data plate found on the motor for proper power supply and wire size.



RISK OF EXPLOSION!

This equipment has internal arcing or parts that may spark and should not be exposed to flammable vapors. Motor should not be located in a recessed area or below floor level. NEVER expose motor to rain or other damp environments. DAMAGE TO MOTOR CAUSED BY WATER IS NOT COVERED UNDER WARRANTY.

NOTE:

CAUTION NEVER OPERATE THE MOTOR ON LINE VOLTAGE LESS THAN 208V. MOTOR DAMAGE MAY OCCUR WHICH IS NOT COVERED UNDER WARRANTY. HAVE A CERTIFIED ELECTRICIAN RUN APPROPRIATE POWER SUPPLY TO MOTOR. SIZE WIRE FOR 25 AMP CIRCUIT. SEE MOTOR OPERATING DATA TABLE. USE SEPARATE CIRCUIT FOR EACH POWER UNIT. PROTECT EACH CIRCUIT WITH TIME DELAY FUSE OR CIRCUITBREAKER. FOR SINGLE PHASE 208-230V, USE 25 AMP FUSE. THREE PHASE 208-240V, USE 25 AMP FUSE. FOR THREE PHASE 400V AND ABOVE, USE 15 AMP FUSE. ALL WIRING MUST COMPLY WITH NECK AND ALL LOCAL ELECTRICAL CODES.

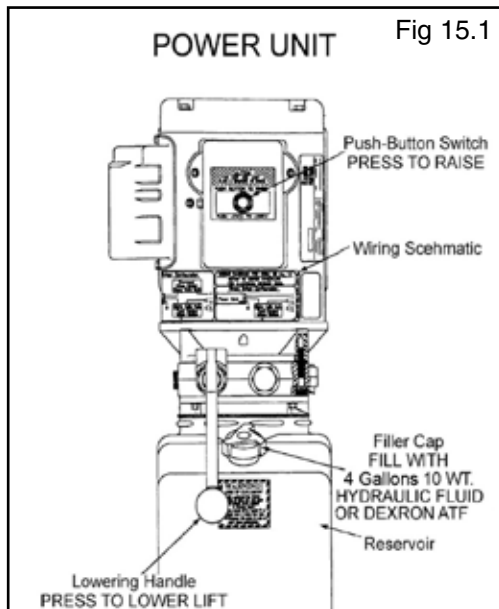

STEP 16 (Lift Start Up / Final Adjustments)



DURING THE START-UP PROCEDURE, OBSERVE ALL OPERATING COMPONENTS AND CHECK FOR PROPER INSTALLATION AND ADJUSTMENT. DO NOT ATTEMPT TO RAISE VEHICLE UNTIL A THOROUGH OPERATIONAL CHECK HAS BEEN COMPLETED.

1. Make sure the power unit reservoir is full with four (4) gallons of 10-WT hydraulic oil or Dexron automatic transmission fluid.
2. Apply light axle grease to the inside of the posts where the slide blocks glide.
3. Test the power unit by pressing the push-button switch. If the motor sounds like it is operating properly, raise the lift and check all hose connections for leaks. If the motor gets hot or sounds peculiar, stop and check all electrical connections.
4. Before proceeding, double-check to make sure all cables are properly positioned within the grooves of ALL sheaves. Make sure all cable sheave retaining pins and/or clips are secure.
5. Check to make sure that all safety locks are cleared and free.
6. Continue to press the button to raise lift until the cables get taut and the lift starts to move.
7. **KEEP HANDS AND FEET CLEAR.** Remove hands and feet from any moving parts. Keep feet clear of lift when lowering. Avoid pinch points.
8. Check all MAIN SAFETY LOCKS to make sure they move freely and spring back to the lock position when released. Lubricate all SAFETY PIVOT points with light spray-oil.
9. Cycle the lift up and down a few times to ensure that the safety locks are engaging uniformly and that the safety release mechanisms are functioning. Re-adjust if necessary.

POST-INSTALLATION CHECK-OFF

- Columns properly shimmed and stable
- Anchor Bolts tightened
- Pivot / Sheave Pins properly attached
- Electric power supply confirmed
- Cables adjusted properly
- Safety Locks functioning properly
- Check for hydraulic leaks
- Oil level
- Lubrication of critical components
- Check for overhead obstructions
- All Screws, Bolts, and Pins securely fastened
- Surrounding area clean
- Operation, Maintenance and Safety Manuals on site.
- Perform an Operational Test with a typical vehicle

STEP 17

(Lubrication)

1. After installation and start up has been completed, lubricate lift components as described below.

(See Fig. 17.1)

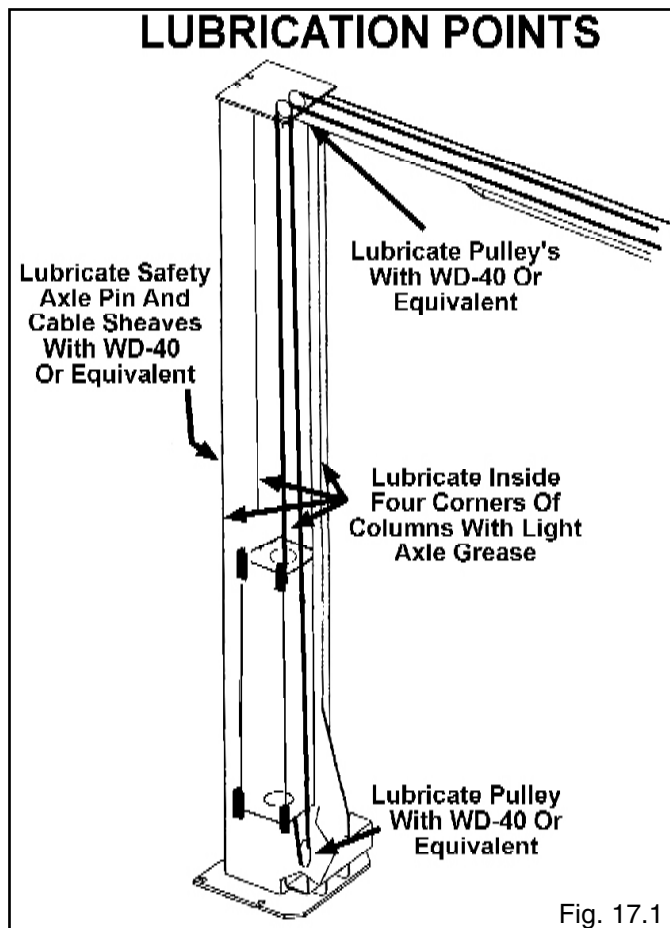

NOTE:

There will be initial stretching of the cables and/or with increased loads. Adjust the cables as outlined above a week after first use, then every three to six months thereafter depending on usage and/or to compensate for stretch.

STEP 18

(Bleeding)



**THE LIFT WILL MOVE DOWN WHEN BLEEDING
MAKE SURE ALL EQUIPMENT, PERSONNEL,
HANDS AND FEET ARE CLEAR
BEFORE BLEEDING**

1. After electrical power is connected and oil reservoir is full, press button to raise lift.
2. Continue raising until lift cylinders fully extend to full height. DO NOT continue pressing button after lift reaches full height. Damage to motor can occur if continued.
3. Lower the lift only HALF WAY by pressing the SAFETY RELEASE handle inward then pressing in the DOWN lever on the power unit.
4. With the lift at half height, slowly loosen the BLEED SCREWS located at the top of each cylinder to bleed trapped air. DO NOT completely remove bleed screws. Re-tighten after trapped air has escaped. (See Fig. 18.1)

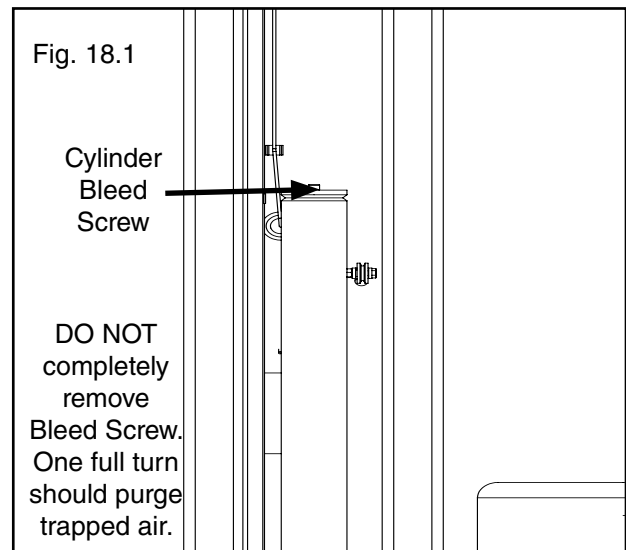

5. Lower the lift completely by pressing the SAFETY RELEASE handle inward then pressing the DOWN lever on power unit. Wait five minutes and repeat bleeding process one additional time.

OPTIONAL EQUIPMENT INSTALLATION

Utility Air-Electric Workstation

Utility Station may be mounted on the vertical column of the lift or on a wall.

IMPORTANT: Check State or Local codes for any height requirements for the electrical outlets before mounting.

To mount the Utility Station on a Lift Column, use the Box as a template, mark and drill 1 1/32" diameter holes. Use 5/16" diameter bolts and lock nuts to secure to the side of the lift.

IMPORTANT: The hole locations are critical to avoid interference with the carriage slide blocks.

For Wall mounting, mount in the same fashion, use appropriate hardware for either sheet rock or concrete.

IMPORTANT: All electrical wiring shall comply with all State and Local Codes.

Connect electrical wiring to single phase, 60Hz 115 volt electrical supply using suitable conduit (not supplied). The duplex receptacle must be connected through the GFCI with the input line to the box connected to a circuit breaker or time delay fuse rated at 20 amps. Both receptacles must be grounded to the box.

Connect main air supply to 1/4" ball valve inlet on the Utility Station (Run 1/2" line from compressor or main air system to Utility Station.)

Install Quick Couplers to the 1/4" male fittings on the box. The air supply between the filter and the lubricator will be non-lubricated, used for tire inflation or blowing off. The air outlet on the left side will be lubricated for air tool use.

Regulator Instructions

- Regulate pressure by raising the knob, then turning clockwise to increase and counterclockwise to decrease. Push knob down to lock setting.
- Adjust the oil mist using the screwdriver slot located on top of the lubricator.
- To fill the lubricator, first depressurize the air system, remove the slotted screw plug in the body. Replace the screw before repressurizing.

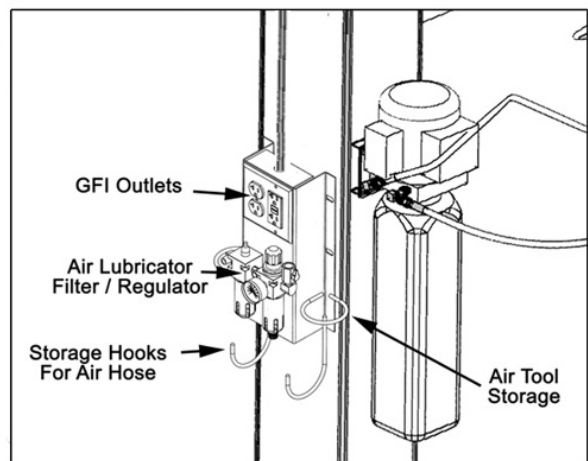
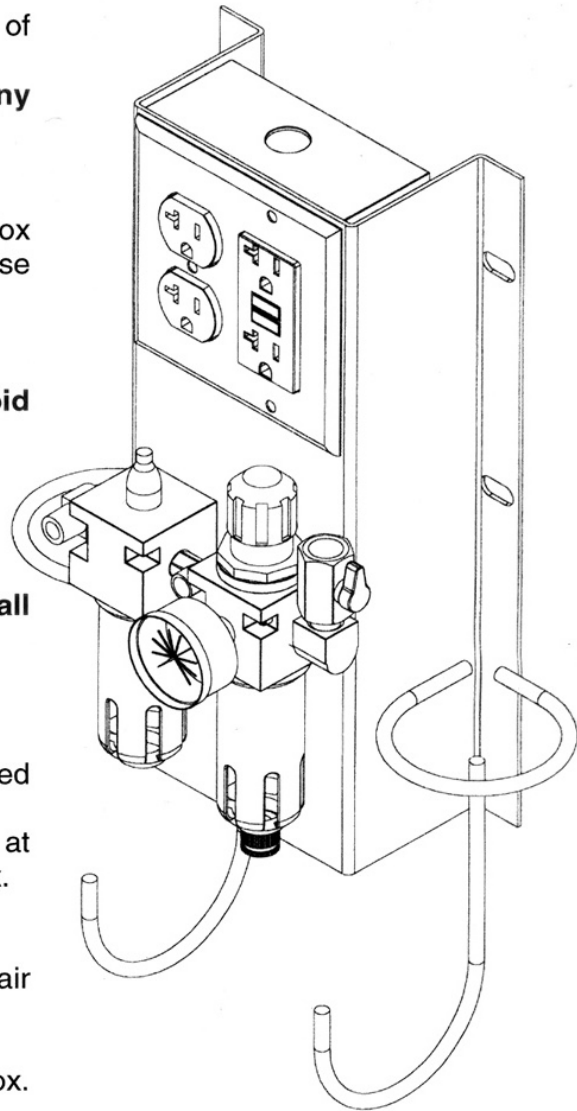

OPTIONAL AND STANDARD ACCESSORIES

- Included Standard
- Not Included Optional

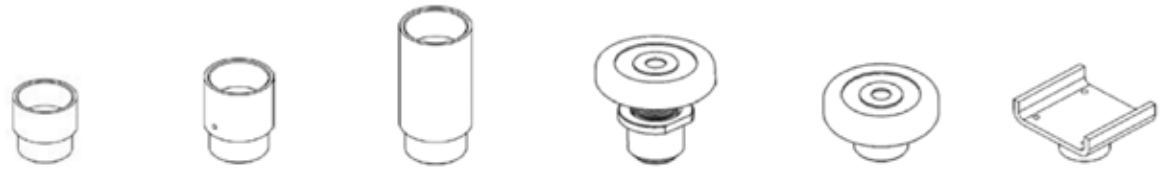

Model No.	44mm. Adapter	63mm. Adapter	125mm. Adapter	Telescoping Screw Pad	Standard Pad	Frame Cradle Pads
XPR-12CL	⊗	☑	☑	⊗	☑	☑
XPR-12CL-192	⊗	☑	☑	⊗	☑	☑
XPR-12CL-LWB	⊗	☑	☑	⊗	☑	☑
XPR-12CL-LWB-192	⊗	☑	☑	⊗	☑	☑
XPR-15CL	⊗	☑	☑	⊗	☑	☑
XPR-15CL-192	⊗	☑	☑	⊗	☑	☑
XPR-18CL	⊗	☑	☑	⊗	☑	☑
XPR-18CL-192	⊗	☑	☑	⊗	☑	☑

Optional Equipment available through your Authorized BendPak Dealer.



Telescoping Screw Pad



Frame Cradle Pad

! DANGER

FRAME CRADLE CONTACT PADS

USE PROPER ADAPTERS

Do not attempt to lift trucks or other frame type vehicles with standard flat contact pads. Frame cradle contact pads are recommended for use when lifting trucks, vans, or other frame vehicles. NEVER use lift with missing or damaged rubber pads. ALWAYS REPLACE rubber contact pads when worn or damaged. Contact BendPak or your BendPak dealer for product information.

If the lift was provided with Lift Arm Foot Guards, install the shorter Foot Guard on the shorter Arm Assembly and the longer Foot Guard on the longer Arm Assembly.

To install firmly squeeze the ends of the Foot Guard inwards and insert the ends underneath the bent ends of the arm support. Release to allow the Foot Guard to spring into place. Check to be sure that Foot Guard is firmly in place.

Repeat this step for each Arm Assembly Foot Guard.

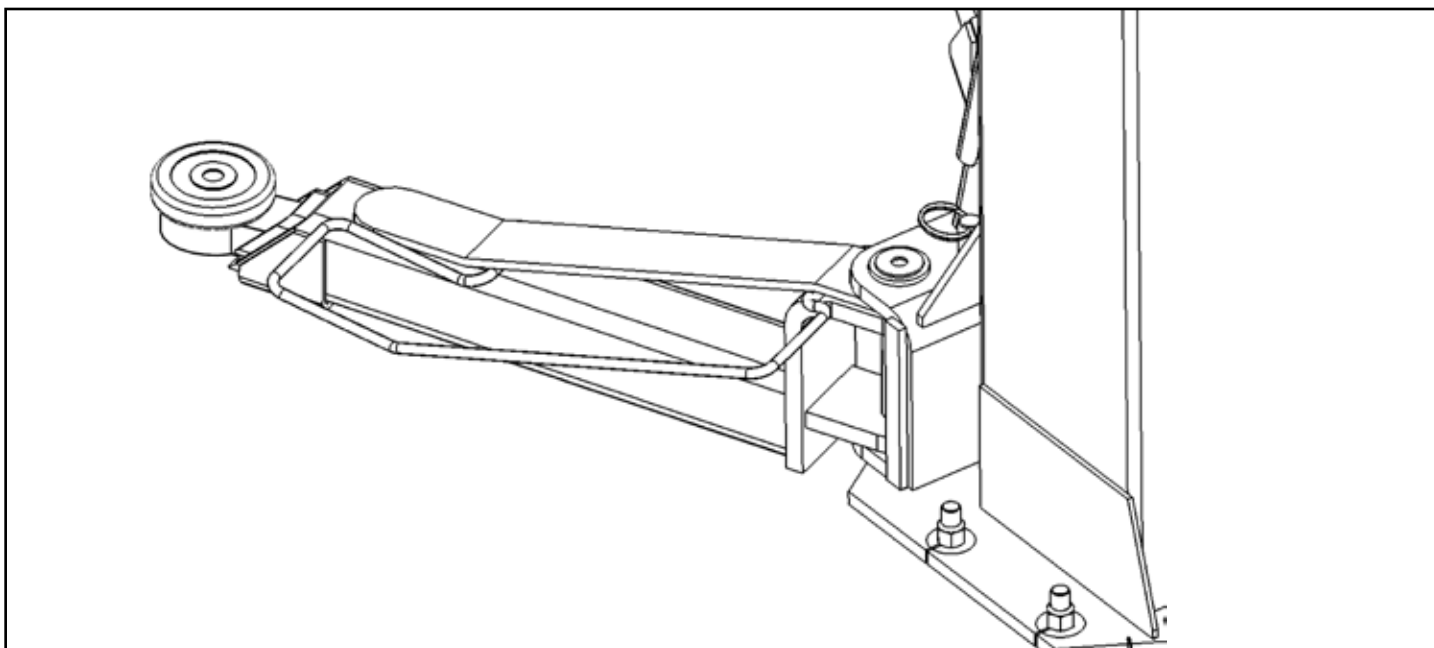
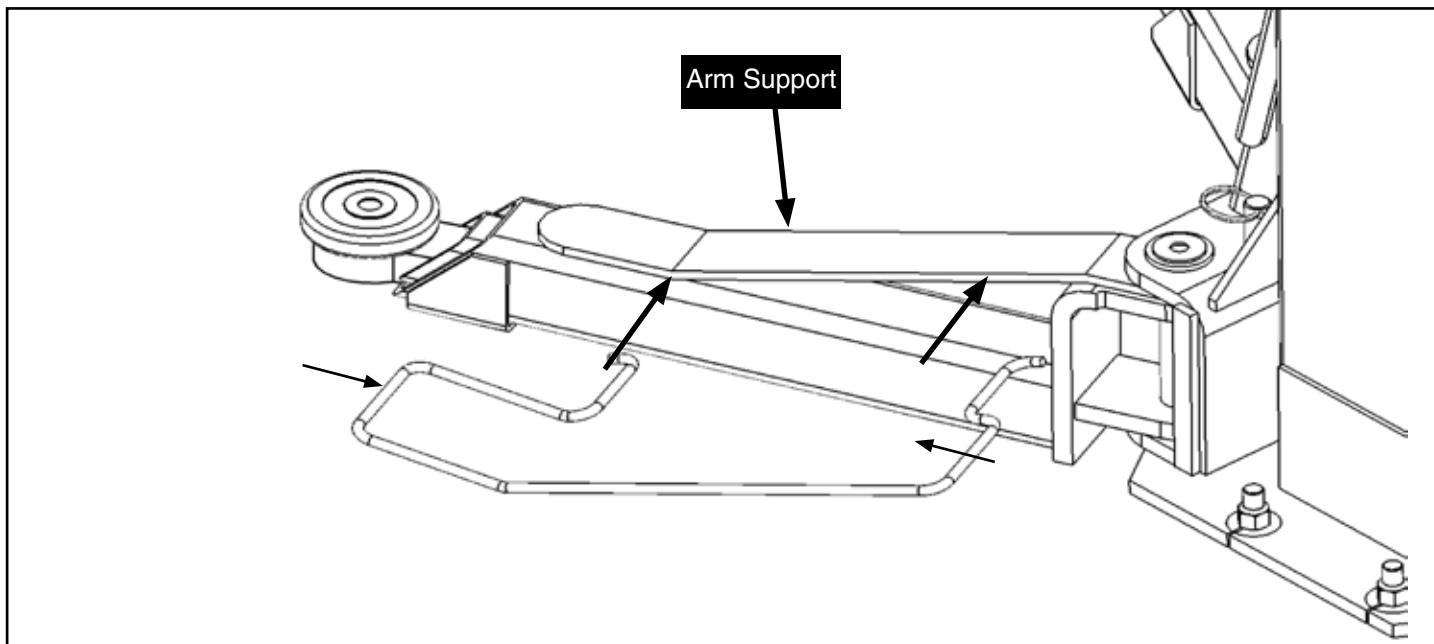

Optional Equipment available through your Authorized BendPak Dealer.

STEP 19 (Operation Instructions)

OWNER/EMPLOYER RESPONSIBILITIES

The Owner/Employer:

- Shall ensure that lift operators are qualified and that they are trained in the safe use and operation of the lift using the manufacturer's operating instructions; ALI/SM01-1, ALI Lifting It Right safety manual; ALI/ST-90 ALI Safety Tips card; ANSI/ALI ALOIM-2000, American National Standard for Automotive Lifts-Safety Requirements for Operation, Inspection and Maintenance; ALI/WL Series, ALI Uniform Warning Label Decals/Placards; and in the case of frame engaging lifts, ALI/LP-GUIDE, Vehicle Lifting Points/Quick Reference Guide for Frame Engaging Lifts.
- Shall establish procedures to periodically inspect the lift in accordance with the lift manufacturer's instructions or ANSI/ALI ALOIM-2000, American National Standard for Automotive Lifts-Safety Requirements for Operation, Inspection and Maintenance; and The Employer shall ensure that lift inspectors are qualified and that they are adequately trained in the inspection of the lift.
- Shall establish procedures to periodically maintain the lift in accordance with the lift manufacturer's instructions or ANSI/ALI ALOIM-2000, American National Standard for Automotive Lifts-Safety Requirements for Operation, Inspection and Maintenance; and The Employer shall ensure that lift maintenance personnel are qualified and that they are adequately trained in the maintenance of the lift.
- Shall maintain the periodic inspection and maintenance records recommended by the manufacturer or ANSI/ALI ALOIM-2000, American National Standard for Automotive Lifts-Safety Requirements for Operation, Inspection and Maintenance.

LIFT OPERATION SAFETY

- **DAILY** inspect your lift. Never operate if it malfunctions or if it has broken or damaged parts. Use **only** qualified lift service personnel and genuine BendPak parts to make repairs.
- **THOROUGHLY** train all employees in use and care of lift, using manufacturer's instructions and "Lifting It Right" and "Safety Tips" supplied with the lift.
- **NEVER** allow unauthorized or untrained persons to position vehicle or operate lift.
- **PROHIBIT** unauthorized persons from being in shop area while lift is in use.
- **DO NOT** permit anyone on lift or inside vehicle when it is either being raised or lowered.

- Shall display the lift manufacturer's operating instructions; ALI/SM 93-1, ALI Lifting It Right safety manual; ALI/ST-90 ALI Safety Tips card; ANSI/ALI ALOIM-2000, American National Standard for Automotive Lifts-Safety Requirements for Operation, Inspection and Maintenance; and in the case of frame engaging lifts, ALI/LP-GUIDE, Vehicle Lifting Points/Quick Reference Guide for Frame Engaging Lifts; in a conspicuous location in the lift area convenient to the operator.
- Shall provide necessary lockout/tagout means for energy sources per ANSI Z244.1-1982 (R1993), Safety Requirements for the Lockout/Tagout of Energy Sources, before beginning any lift repairs.
- Shall not modify the lift in any manner without the prior written consent of the manufacturer.



- **ALWAYS** keep area around lift free of tools, debris, grease and oil.
- **NEVER** overload lift. Capacity of lift is shown on nameplate affixed to the lift.
- **DO NOT** stand in front of the vehicle while it is being positioned in lift bay.
- **DO NOT** hit or run over lift arms or adapters. This could damage lift or vehicle. Before driving vehicle into lift bay, position arms and adapters to provide unobstructed entrance onto lift.

LIFT OPERATION SAFETY (CONT'D)

- **ALWAYS** load vehicle on lift carefully. Position the lift adapters to contact at the vehicle manufacturer's recommended lift points. Raise lift until adapters contact vehicle. Check adapters for secure contact with vehicle. Raise lift to desired working height. (See Fig.19.1)

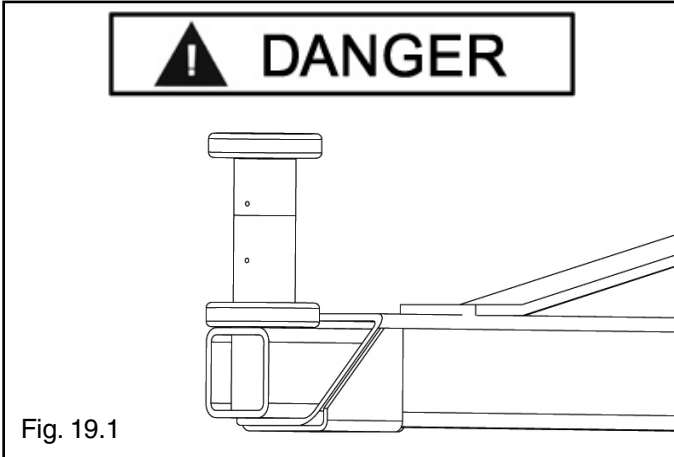

Fig. 19.1

- **DO NOT** block open or override self-closing lift controls; they are designed to return to the "Off" or Neutral position when released.
- **DO NOT** remove or disable arm restraints.
- **ALWAYS** remain clear of lift when raising or lowering vehicles.
- **ALWAYS** use safety stands when removing or installing heavy components.
- **DO NOT** go under raised vehicle if safety locks are not engaged.



VISUALLY CONFIRM THAT ALL PRIMARY SAFETY LOCKS ARE ENGAGED BEFORE ENTERING WORK AREA. SUSPENSION COMPONENTS USED ON THIS LIFT ARE INTENDED TO RAISE AND LOWER LIFT ONLY AND ARE NOT MEANT TO BE LOAD HOLDING DEVICES. REMAIN CLEAR OF ELEVATED LIFT UNLESS VISUAL CONFIRMATION IS MADE THAT ALL PRIMARY SAFETY LOCKS ARE FULLY ENGAGED AND THE LIFT IS LOWERED ONTO THE SAFETY LOCKS, REFER TO INSTALLATION/OPERATION MANUAL FOR PROPER SAFETY LOCK PROCEDURES AND/OR FURTHER INSTRUCTION.

- **NEVER LEAVE LIFT IN ELEVATED CONDITION** unless all Safety Locks are engaged.
- **AVOID** excessive rocking of vehicle while on lift.



WHEN LOWERING THE LIFT PAY CAREFUL ATTENTION THAT ALL PERSONNEL AND OBJECTS ARE KEPT CLEAR. ALWAYS KEEP A VISUAL LINE OF SITE ON THE LIFT AT ALL TIMES. ALWAYS MAKE SURE THAT ALL LOCKS ARE DISENGAGED. IF ONE OF THE LOCKS INADVERTENTLY LOCKS UPON DESCENT THE VEHICLE MAY DISMOUNT CAUSING PERSONAL INJURY OR DEATH.

- **ALWAYS CLEAR AREA** if vehicle is in danger of falling.
- **ALWAYS REMOVE** tool trays, stands, etc. before lowering lift.
- **ALWAYS RELEASE** safety locks before attempting to lower lift.
- **ALWAYS POSITION** the lift arms and adapters to provide an unobstructed exit before removing vehicle from lift area.

TO RAISE THE LIFT

1. Before Loading: Lift must be fully lowered and service bay clear of all personnel before the vehicle is brought on lift with the swing arms set to the full drive-thru position.



TO AVOID PERSONAL INJURY AND/OR PROPERTY DAMAGE, PERMIT ONLY TRAINED PERSONNEL TO OPERATE LIFT. AFTER REVIEWING THESE INSTRUCTIONS, PRACTICE USING LIFT CONTROLS BY RUNNING THE LIFT THROUGH A FEW UNLOADED CYCLES BEFORE LOADING VEHICLE ON LIFT. ALWAYS LIFT THE VEHICLE USING ALL FOUR ADAPTERS. NEVER RAISE JUST ONE END, ONE CORNER, OR ONE SIDE OF VEHICLE.

2. Loading: Swing arms under vehicle and position adapters at vehicle manufacturer's recommended lift points. Use height extenders or optional frame-cradle adapters when necessary to ensure good contact. (See Fig 19.2 - 19.3)
3. Some vehicles may have the manufacturer's Service Garage Lift Point locations identified by triangle shape marks on the undercarriage (reference ANSI/SAE J2184-1992). Also, there may be a label located on the right front door jamb area showing specific vehicle lift points.

LIFT OPERATION SAFETY (CONT'D)

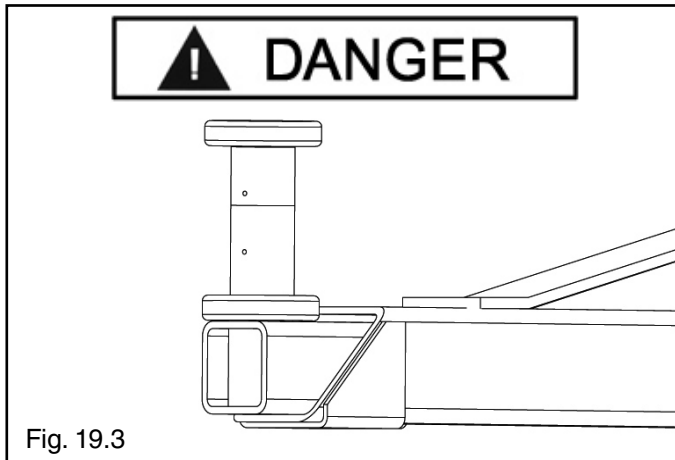
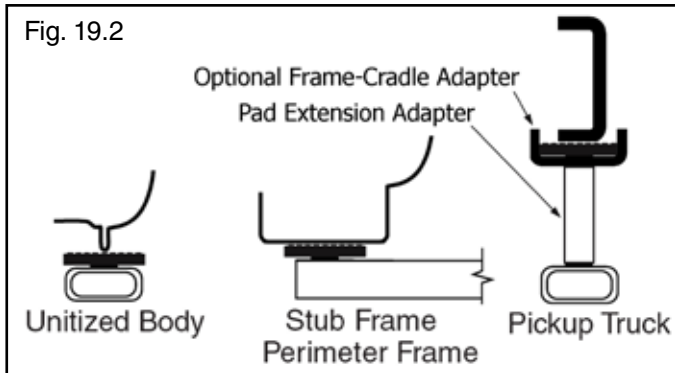

4. Position vehicle for proper weight distribution arms under vehicle to allow adapters to contact at the manufacturer's recommended pick up points.

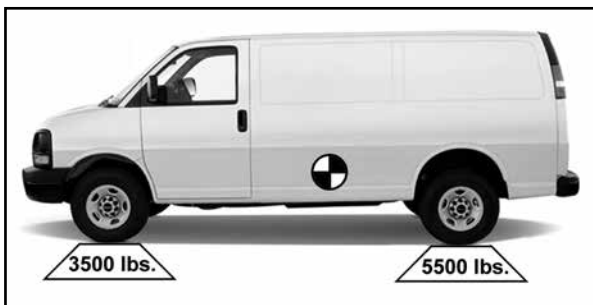

5. If the specific vehicle lift points are not identified, refer to the VEHICLE CENTER OF BALANCE instructions found on our website at:

<http://www.bendpak.com/support/balancing-safety/>

6. Push the **RAISE** button or rotate the control switch on the power unit.

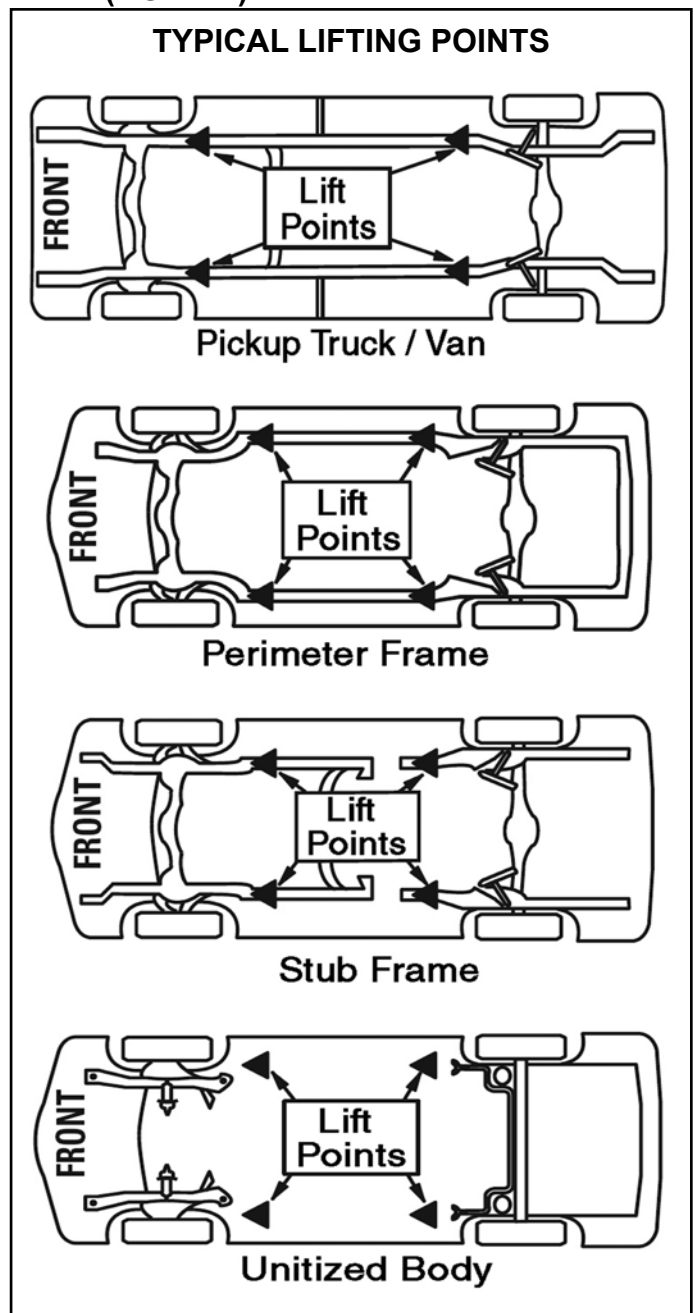

NOTE:
ALLOW (2) SECONDS BETWEEN MOTOR STARTS.
FAILURE TO COMPLY MAY CAUSE MOTOR BURNOUT.

7. Stop before making contact with vehicle. Check arm restraint pins for engagement. If required, slightly move arm to allow restraint gear and pawl to mesh. **DO NOT** hammer arm restraint pin down as this will damage the restraint gear teeth.
8. Raise vehicle until tires clear the floor.
9. Stop and check adapters for secure contact at vehicle manufacturer's recommended lift points.

LIFT OPERATION SAFETY (CONT'D)

10. Continue to raise to desired height only if vehicle is secure on lift.

11. **DO NOT** go near or under a raised vehicle if all four adapters are not in secure contact with vehicle at vehicle manufacturer's recommended lift points.

12. Repeat entire loading and raising procedures if required.



VISUALLY CONFIRM THAT ALL PRIMARY SAFETY LOCKS ARE ENGAGED BEFORE ENTERING WORK AREA. SUSPENSION COMPONENTS USED ON THIS LIFT ARE INTENDED TO RAISE AND LOWER LIFT ONLY AND ARE NOT MEANT TO BE LOAD HOLDING DEVICES. REMAIN CLEAR OF ELEVATED LIFT UNLESS VISUAL CONFIRMATION IS MADE THAT ALL PRIMARY SAFETY LOCKS ARE FULLY ENGAGED AND THE LIFT IS LOWERED ONTO THE SAFETY LOCKS, REFER TO INSTALLATION / OPERATION MANUAL FOR PROPER SAFETY.

13. Lower lift onto safety locks.

- **DO NOT** enter work area or go under vehicle if safety locks are not engaged.

- **CLEAR AREA** if vehicle is in danger of falling.

- **DO NOT** position yourself between a wall and the lift. If the vehicle falls in that direction, you may be severely injured or killed.

- Before attempting to lift pickup trucks or other truck frame vehicles, be sure that:

- ◆ Vehicle frame is strong enough to support its weight and has not been weakened by modification or corrosion.
- ◆ Vehicle individual axle weight does not exceed one-half lift capacity.
- ◆ Adapters are in secure contact with frame at vehicle manufacturers recommended lift points.
- ◆ Vehicle is stable on lift and the center of gravity is NOT off balance.
- ◆ The overhead switch bar will contact the highest point on the vehicle.

WHILE USING LIFT

- Avoid excessive rocking of vehicle while on lift.
- Always use safety stands as needed or when removing or installing heavy components.



WHEN LOWERING THE LIFT PAY CAREFUL ATTENTION THAT ALL PERSONNEL AND OBJECTS ARE KEPT CLEAR. ALWAYS KEEP A VISUAL LINE OF SITE ON THE LIFT AT ALL TIMES. ALWAYS MAKE SURE THAT ALL LOCKS ARE DISENGAGED. IF ONE OF THE LOCKS INADVERTENTLY LOCKS ON DESCENT THE LIFT AND/OR VEHICLE MAY DISRUPT CAUSING PERSONAL INJURY OR DEATH.

TO LOWER THE LIFT

1. Remove all tools or other objects from the lift area.
2. Raise lift off safety locks.
3. Push safety lock release handle fully and hold.
4. Push LOWERING valve handle to lower. Note: Both SAFETY LOCK release and LOWERING valve handles must be held down simultaneously to lower lift. Do not override self-closing lift controls.
5. Remain clear of lift when lowering vehicle. Observe pinch point warning decals.
6. Remove adapters from under vehicle and swing arms to full drive-thru position before moving vehicle.
7. If lift is not operating properly, DO NOT use until adjustment or repairs are made by qualified lift service personnel.



IF YOU ARE NOT COMPLETELY FAMILIAR WITH AUTOMOTIVE LIFT MAINTENANCE PROCEDURES; STOP AND CONTACT THE MANUFACTURER FOR INSTRUCTIONS. TO AVOID PERSONAL INJURY, PERMIT ONLY QUALIFIED PERSONNEL TO PERFORM MAINTENANCE ON THIS EQUIPMENT.

MAINTENANCE INSTRUCTIONS

- Always keep bolts tight. Check periodically.
- Always keep lift components clean.
- Always if oil leakage is observed, call local service representative.
- Always call local service representative if electrical problems develop.

LIFT OPERATION SAFETY (CONT'D)

- Always replace ALL FAULTY PARTS before lift is put back into operation.
- Daily: Make a visual inspection of ALL MOVING PARTS and check for excessive signs of wear.
- Daily: Check safety locks to ensure they are in good operating condition.
- Daily: Check cables and sheaves for wear. Replace worn parts as required with genuine BendPak parts.
- Daily: Inspect adapters for damage or excessive wear. Replace as required with genuine BendPak parts.
- Weekly: Lubricate all sheave and rollers with general purpose oil.
- Weekly: Check all cable connections, bolts and pins to ensure proper mounting.
- Monthly: Check equalizer cable tension. Adjust per lift installation instructions.
- Monthly: Lubricate locking latch shafts. Push latch handle several times for oil to penetrate pivot points.
- Every 3 Months: Check anchor bolt torque. Anchors should be torqued to 90 ft/lbs.
- Semi-Annually: Check fluid level of lift power unit and refill if required per lift installation instructions.
- Replace all caution, warning or safety related decals on the lift if unable to read or missing. Reorder labels from BendPak.
- Refer to ANSI/ALI ALOIM booklet for periodic inspection checklist and maintenance log sheet.



Before lifting the vehicle, make sure it is neither front nor rear heavy. See image below. Center of balance should be midway between adapters.

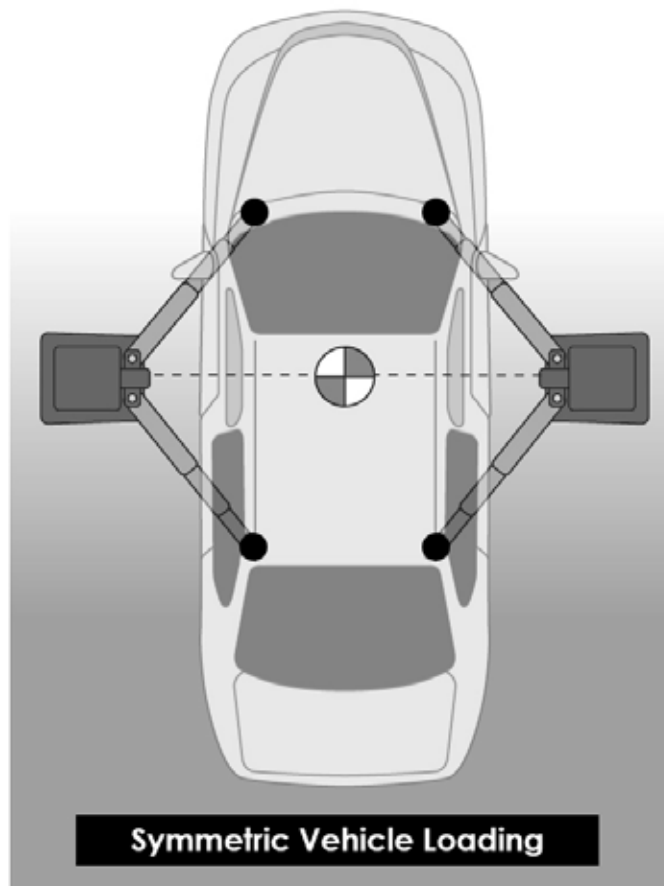

TO RAISE LIFT

- ◆ Read operating and Safety manuals before using lift.
- ◆ Always lift a vehicle according to the manufacturers recommended lifting points.
- ◆ Position vehicle between columns.
- ◆ Adjust swing arms so that the vehicle is positioned with the center of gravity midway between pads.
- ◆ Use truck adapters as needed. Never exceed 9" of Pad height.
- ◆ **NEVER** use lift pad assemblies without rubber slip over pads in place.
- ◆ Raise the vehicle by depressing button until the vehicle just lifts off the ground. Re-check to make sure the vehicle is secure and all locking pins are lock in place.
- ◆ Raise vehicle to desired height. Lower vehicle onto nearest safety,
- ◆ Always ensure safeties are engaged before any attempt is made to work on or near vehicle.

TO LOWER THE LIFT

- ◆ First raise the lift clear to the safeties.
- ◆ Release safeties by pulling on the safety handle.
- ◆ Be sure tool trays, stands or personnel are cleared from under the vehicle.
- ◆ Lower vehicle by activating lowering handle on power unit.
- ◆ Before removing vehicle from lift; position lift arms and supports to provide an unobstructed exit.
- ◆ **NEVER**, drive over lift arms.

REQUIRED MONTHLY MAINTENANCE

- ◆ Check all arm adjusting locks for proper operation.
- ◆ Check all cables connections, bolts and pins to ensure proper mounting and torque.
- ◆ Visually inspect safeties for proper operation.
- ◆ Lubricate columns with grease.
- ◆ Inspect all anchors bolts and retighten if necessary.
- ◆ Check all columns for squareness and plumb.
- ◆ Inspect all pivot arms pins making sure they are properly secure.
- ◆ Check equalizer cable tension, and adjust if necessary.
- ◆ If lift is equipped with over head cut-off switch, check for proper operation.



1. **WARNING!** If cement anchor bolts are loose or any component of the lift is found to be defective, **DO NOT USE THE LIFT!!**
2. Never operate the lift with any person or equipment below the vehicle.
3. Never exceed the rated lift capacity.
4. Always ensure the safeties are engaged before any attempt is made to work on or near the vehicle.
5. Never leave lift in elevated position unless the safeties are engaged.
6. Do not permit electric motor to get wet! Motor damage caused by dampness is not covered under warranty.



**NEVER LIFT ANY VEHICLE IN ANY MANNER WITH
LESS THAN ALL FOUR (4) ARMS. RATED CAPACITY OF
EACH LIFT ARM IS NO GREATER THAN ONE FOURTH
(1/4) OF THE OVERALL LIFT CAPACITY.**



WARNING

WIRE ROPE INSPECTION AND MAINTENANCE

◆ Lifting cables should be replaced every three - five years or when visible signs of damage are apparent. **DO NOT USE LIFT WITH DEFECTIVE / WORN CABLES.**

◆ Lifting cables should be maintained in a well-lubricated condition at all times. Wire rope is only fully protected when each wire strand is lubricated both internal and external. Excessive wear will shorten the life of the wire rope. The factory suggested wire rope lubricant that penetrates to the core of the rope and provides long-term lubrication between each individual strand is 90-WT gear oil or ALMASOL® Wire Rope Lubricant. In order to make sure that the inner layers of the rope remain well lubricated, lubrication should be carried out at intervals not exceeding three months during operation.

◆ All sheaves and guide rollers in contact with the moving rope should be given regular visual checks for surface wear and lubricated to make sure that they run freely. This operation should be carried out at appropriate intervals generally not exceeding three months during operation. For all sheave axles, the factory recommends standard wheel bearing grease. For all sheaves and/or guide rollers, the factory recommends 90-WT gear oil or similar heavy lubricant applied by any method including pump / spray dispensing, brush, hand and/or swabbing.

HOW OFTEN TO INSPECT

◆ Lifting cables should be visually inspected at least once each day when in use, as suggested by American Petroleum Institute (API) RP54 guidelines.

◆ Any lifting cables that have met the criteria for removal must be immediately replaced.

WHEN TO REPLACE LIFTING CABLES DUE TO BROKEN WIRES

◆ Lifting cables should be removed from service when you see six randomly distributed broken wires within any one lay length, or three broken wires in one strand within one lay length.

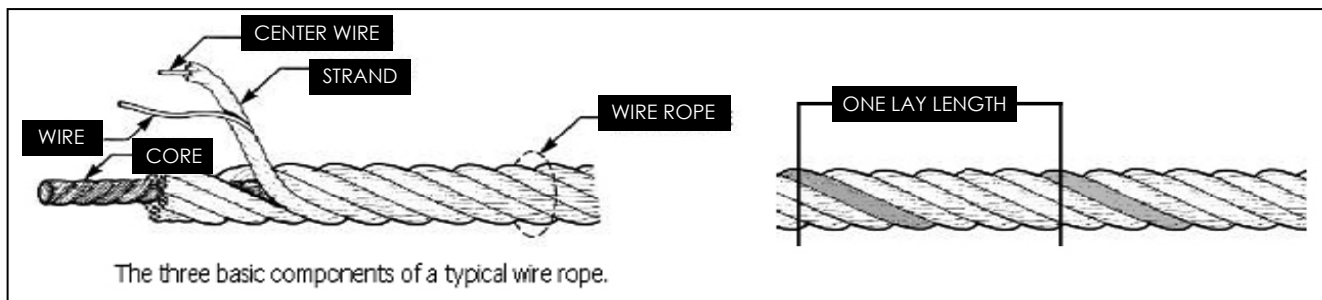

OTHER REASONS TO REPLACE LIFTING CABLES

- ◆ Corrosion that pits the wires and/or connectors.
- ◆ Evidence of kinking, crushing, cutting, bird-caging or a popped core.
- ◆ Wear that exceeds 10% of a wire's original diameter.
- ◆ Evidence of heat damage.

HOW TO FIND BROKEN WIRES

◆ The first step is to relax your rope to a stationary position and move the pick-up points off the sheaves. Clean the surface of the rope with a cloth — a wire brush, if necessary — so you can see any breaks.

◆ Flex the rope to expose any broken wires hidden in the valleys between the strands.

◆ Visually check for any broken wires. One way to check for crown breaks is to run a cloth along the rope to check for possible snags.

◆ With an awl, probe between wires and strands and lift any wires that appear loose. Evidence of internal broken wires may require a more extensive rope examination.

! WARNING

WIRE ROPE INSPECTION AND MAINTENANCE

- Lifting cables should be replaced every three years or when visible signs of damage are apparent. **DO NOT USE LIFT WITH DEFECTIVE: WORN CABLES.**
- Wire rope should be maintained in a well-lubricated condition at all times. Wire rope is only fully protected when each wire strand is lubricated both internally and externally. Excessive wear will shorten the life of the wire rope. The factory suggested wire rope lubricant that penetrates to the core of the rope and provides long term lubrication between each individual strand is AMSOIL Synthetic Open Gear and Wire Rope Compound or 90WT gear oil or similar heavy lubricant. In order to make sure that the inner layers of the rope remains well lubricated, lubrication should be carried out at intervals not exceeding three months during operation.
- All sheaves and guide rollers in contact with the moving rope should be given regular visual checks for surface wear and lubricated to make sure that they run freely. This operation should be carried out at appropriate intervals generally not exceeding three months during operation. For all sheave axles, the factory recommends standard wheel bearing grease. For all sheaves and /or guide rollers, the factory recommends 90 WT gear oil or similar heavy lubricant applied by any method including pump / spray dispensing, brush, hand and /or swabbing.

Failure to read, understand, and follow these instructions may cause death or serious injury.
Read and understand these instructions before using lift.

SAFETY INSTRUCTIONS



Read operating and safety manuals before using lift.

©

SAFETY INSTRUCTIONS



Proper maintenance and inspection is necessary for safe operation.

©

SAFETY INSTRUCTIONS



Do not operate a damaged lift.

©

The messages and pictographs shown are generic in nature and are meant to generally represent hazards common to all automotive lifts regardless of specific style



Funding for the development and validation of these labels was provided by the Automotive Lift Institute, PO Box 33116 Indianalantic, FL 32903



They are protected by copyright
Set of labels may be obtained from
ALI or its member companies

© 1992 by ALI, Inc

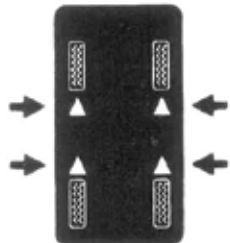
ALI/WL1018

<p>⚠ CAUTION</p>  <p>Lift to be used by trained operator only.</p>	<p>⚠ CAUTION</p>  <p>Authorized personnel only in lift area.</p>
------------------------------------------------------------------------------------------------------------------------------------------------------------	----------------------------------------------------------------------------------------------------------------------------------------------------------

<p>⚠ CAUTION</p>  <p>Use vehicle manufacturer's lift points.</p>	<p>⚠ CAUTION</p>  <p>Always use safety stands when removing or installing heavy components.</p>
----------------------------------------------------------------------------------------------------------------------------------------------------------	-----------------------------------------------------------------------------------------------------------------------------------------------------------------------------------------

<p>⚠ CAUTION</p>  <p>Use height extenders when necessary to ensure good contact.</p>	<p>⚠ CAUTION</p>  <p>Auxiliary adapters may reduce load capacity.</p>
--------------------------------------------------------------------------------------------------------------------------------------------------------------------------------	-----------------------------------------------------------------------------------------------------------------------------------------------------------------

The messages and pictographs shown are generic in nature and are meant to generally represent hazards common to all automotive lifts regardless of specific style.

Funding for the development and validation of these labels was provided by the Automotive Lift Institute, PO Box 33116 Indialantic, FL. 32903.

They are protected by copyright. Set of labels may be obtained from ALI or its member companies.

© 1992 by ALI, Inc. ALI/WL101c

<p>⚠ WARNING</p>  <p>Clear area if vehicle is in danger of falling.</p>	<p>⚠ WARNING</p>  <p>Position vehicle with center of gravity midway between adapters.</p>
------------------------------------------------------------------------------------------------------------------------------------------------------------------	-------------------------------------------------------------------------------------------------------------------------------------------------------------------------------------

<p>⚠ WARNING</p>  <p>Remain clear of lift when raising or lowering vehicle.</p>	<p>⚠ WARNING</p>  <p>Avoid excessive rocking of vehicle while on lift.</p>
--------------------------------------------------------------------------------------------------------------------------------------------------------------------------	----------------------------------------------------------------------------------------------------------------------------------------------------------------------

<p>⚠ WARNING</p>  <p>Do not override self-closing lift controls.</p>	<p>⚠ WARNING</p>  <p>Keep feet clear of lift while lowering.</p>
-----------------------------------------------------------------------------------------------------------------------------------------------------------------	--------------------------------------------------------------------------------------------------------------------------------------------------------------

The messages and pictographs shown are generic in nature and are meant to generally represent hazards common to all automotive lifts regardless of specific style.

Funding for the development and validation of these labels was provided by the Automotive Lift Institute, PO Box 33116 Indialantic, FL. 32903.

They are protected by copyright. Set of labels may be obtained from ALI or its member companies.

© 1992 by ALI, Inc. ALI/WL101w

Safe Lift Operation

Automotive and truck lifts are critical to the operation and profitability of your business. The safe use of this and other lifts in your shop is critical in preventing employee injuries and damage to customer's vehicles. By operating lifts safely you can ensure that your shop is profitable, productive and safe.

Safe operation of automotive lifts requires that only trained employees should be allowed to use the lift.

TRAINING SHOULD INCLUDE, BUT NOT LIMITED TO:

- ◆ Proper positioning of the vehicle on the lift arms. (See manufacturers minimize wheel base loading requirements.)
- ◆ Use of the operating controls.
- ◆ Understanding the lift capacity.
- ◆ Proper use of jack stands or other load supporting devices.
- ◆ Proper use, understanding and visual identification of safety lock devices and their operation.
- ◆ Reviewing the safety rules.
- ◆ Proper housekeeping procedures (lift area should be free of grease, oil, tools, equipment, trash, and other debris).
- ◆ A daily inspection of the lift should be completed prior to its use. Safety devices, operating controls, lift arms and other critical parts should be inspected prior to using the lift.
- ◆ All maintenance and repairs of the lift should be completed by following the manufacturer's requirements. Lift repair parts should meet or exceed OEM specifications. Repairs should only be completed by a qualified lift technician.
- ◆ The vehicle manufacturer's recommendations should be used for spotting and lifting the vehicle.

LIFT OPERATION / SAFETY

- ◆ It is important that you know the load limit. Be careful that you do not overload the lift . If you are unsure what the load limit is, check the data plate found on one of the lift columns or contact the manufacturer.
- ◆ The center of gravity should be followed closely to what the manufacturer recommends.
- ◆ Always make sure you have proper overhead clearance. Additionally, check that attachments, (vehicle signs, campers, antennas, etc.) are not in the way.
- ◆ Be sure that prior to the vehicle being raised, the doors, trunk, and hood are closed securely.
- ◆ Prior to being raised, make sure there is no one standing closer than six feet from the lift.
- ◆ After positioning the vehicle on the lift runways, set the emergency brake, make sure the ignition is off, the doors are closed, overhead obstructions are cleared, and the transmission is in neutral.
- ◆ Double check that the automatic chock devices are in position and then when the lift is raised, observe the chocks.
- ◆ Put pads or adapters in the right position under the contact points that have been recommended.
- ◆ The lift should be raised just until the vehicle's wheels are about one foot off the ground. If contact with the vehicle is uneven or it appears that the vehicle is not sitting secure, carefully lower the lift and readjust.
- ◆ Always consider potential problems that might cause a vehicle to slip, i.e., heavy cargo, undercoating, etc.
- ◆ Pay attention when walking under a vehicle that is up on the hydraulic lift.



- ◆ **DO NOT** leave the controls while the lift is still in motion.
- ◆ **DO NOT** stand directly in front of the vehicle or in the bay when vehicle is being loaded or driven into position.
- ◆ **DO NOT** go near vehicle or attempt to work on the vehicle when being raised or lowered.
- ◆ **REMAIN CLEAR** of lift when raising or lowering vehicle.
- ◆ **DO NOT** rock the vehicle while on the lift or remove any heavy component from vehicle that may cause excessive weight shift.
- ◆ **DO NOT** lower the vehicle until people, materials, and tools are clear
- ◆ **ALWAYS ENSURE** that the safeties are engaged and lowered on to the safety ladders before any attempt is made to work on or near vehicle.
- ◆ Some vehicle maintenance and repair activities may cause the vehicle to shift. Follow the manufacturer's guidelines when performing these operations. The use of jack stands or alternate lift points may be required when completing some repairs.
- ◆ **READ AND UNDERSTAND** all safety warning procedures before operating lift.
- ◆ **KEEP HANDS AND FEET CLEAR.** Remove hands and feet from any moving parts. Keep feet clear of lift when lowering. Avoid pinch points.
- ◆ **ONLY TRAINED OPERATORS** should operate this lift. All non-trained personnel should be kept away from work area. Never let non-trained personnel come in contact with, or operate lift.
- ◆ **USE LIFT CORRECTLY.** Use lift in the proper manner. Never use lifting adapters other than what is approved by the manufacturer.
- ◆ **DO NOT** override self-closing lift controls.
- ◆ **CLEAR AREA** if vehicle is on danger of falling.
- ◆ **STAY ALERT.** Watch what you are doing. Use common sense. Be aware.
- ◆ **CHECK FOR DAMAGED PARTS.** Check for alignment of moving parts, breakage of parts or any condition that may affect its operation. Do not use lift if any component is broken or damaged.
- ◆ **NEVER** remove safety related components from the lift. Do not use lift if safety related components are damaged or missing.
- ◆ When the lift is being lowered, make sure everyone is standing at least six feet away.
- ◆ Be sure there are no jacks, tools, equipment, left under the lift before lowering.
- ◆ Always lower the vehicle down slowly and smoothly.

LIFT WILL NOT RAISE

POSSIBLE CAUSE

1. Air in oil, (1,2,8,13)
2. Cylinder binding, (9)
3. Cylinder leaks internally, (9)
4. Motor run backward under pressure, (11)
5. Lowering valve leaks, (3,4,6,10,11)
6. Motor runs backwards, (7,14,11)
7. Pump damaged, (10,11)
8. Pump won't prime, (1,8,13,14,3,12,10,11)
9. Relief valve leaks, (10,11)
10. Voltage to motor incorrect, (7,14,11)

REMEDY

INSTRUCTION

- | | |
|-----------------------------------------------------------------------|------------------------------------------------------------------------------------------------|
| 1. Check for proper oil level. | The oil level should be up to the bleed screw in the reservoir with the lift all the way down. |
| 2. Bleed cylinders. | See Installation Manual |
| 3. Flush- Release valve to get rid of. possible contamination | Hold release handle down and start unit allowing it to run for 15 seconds. |
| 4. Dirty oil. | Replace oil with clean Dexron ATF. |
| 5. Tighten all fasteners. | Tighten fasteners to recommended torques. |
| 6. Check for free movement of release. | If handle does not move freely, replace bracket or handle assembly. |
| 7. Check motor is wired correctly. | Compare wiring of motor to electrical diagram on drawing. |
| 8. Oil seal damaged or cocked | Replace oil seal around pump shaft. |
| 9. See Installation Manual | Consult Lift Manufacturer. |
| 10. Replace with new part | Replace with new part. |
| 11. Return unit for repair | Return unit for repair. |
| 12. Check pump-mounting bolts | Bolts should be 15 to 18 ft. lbs. |
| 13. Inlet screen clogged | Clean inlet screen or replace. |
| 14. Check wall outlet voltages and wiring | Make sure unit and wall outlet are wired properly. |

MOTOR WILL NOT RUN

POSSIBLE CAUSE

1. Fuse blown, (5,2,1,3,4)
2. Limit switch burned out, (1,2,3,4)
3. Microswitch burned out, (1,2,3,4)
4. Motor burned out, (1,2,3,4,6)
5. Voltage to motor incorrect, (2,1,8)

REMEDY

1. Check for correct voltage
2. Check motor is wired correctly
3. Don't use extension cords
4. Replace with new part
5. Reset circuit breaker/fuse
6. Return unit for repair
7. See Installation Manual
8. Check wall outlet voltage and wiring

INSTRUCTIONS

- Compare supply voltage with voltage on motor name tag. Check that the wire is sized correctly. N.E.C table 310-12 requires AWG 10 for 25 amps.
- Compare wiring of motor to electrical diagram on drawing.
- According to N.E.C. : " The size of the conductors should be such that the voltage drop would not exceed 3% to the farthest outlet for power. *Do not run motor at 115 VAC - damage to the motor will occur.
- Replace with new part.
- Reset circuit breaker/fuse.
- Return unit for repair.
- See Installation Manual.
- Make sure unit and wall outlet is wired properly. Motor must run at 208/230 VAC.

LIFT LOWERS SLOWLY OR NOT AT ALL

POSSIBLE CAUSE

1. Cylinders binding, (1)
2. Release valve clogged, (5,4,2,3)
3. Pressure fitting too long, (6)

REMEDY

1. See Installation Manual
2. Replace with new part
3. Return for repair
4. Check oil.
5. Clean release valve
6. Replace fitting with short thread lead

INSTRUCTIONS

- Consult Lift Manufacturer.
- Replace with new part.
- Return for repair.
- Use clean 10-WT hydraulic oil or Dexron automatic transmission fluid only. If ATF is contaminated, replace with clean ATF and clean entire system.
- Wash release valve in solvent and blow out with air.
- Replace fitting with short thread lead.

WILL NOT RAISE LOADED LIFT

POSSIBLE CAUSE

1. Air in oil, (1,2,3,4)
2. Cylinder binding, (5)
3. Cylinder leaks internally, (5)
4. Lift overloaded, (6,5)
5. Lowering valve leaks, (7,8,1,5,9)
6. Motor runs backwards, (10,12,9)
7. Pump damaged, (5,9)
8. Pump won't prime, (1,2,3,4,5,11,9)
9. Relief valve leaks, (8,5,9)
10. Voltage to motor incorrect, (10,12,5)

REMEDY

- | | |
|----------------------------------------------------|------------------------------------------------------------------------------------------------|
| 1. Check oil level | The oil level should be up to the bleed screw in the reservoir with the lift all the way down. |
| 2. Check/Tighten inlet tubes | Replace inlet hose assembly. |
| 3. Oil seal damaged or cocked | Replace oil seal and install. |
| 4. Bleed cylinders | See Installation Manual. |
| 5. See Installation Manual | Consult Lift Manufacturer. |
| 6. Check vehicle weight | Compare weight of vehicle to weight limit of the lift. |
| 7. Flush release valve | Hold release handle down and start unit allowing it to run for 15 seconds. |
| 8. Replace with new part | Replace with new part. |
| 9. Return unit for repair | Return unit for repair. |
| 10. Check motor is wired correctly | Compare wiring of motor to electrical diagram on power unit drawing. |
| 11. Inlet screen clogged | Clean inlet screen or replace. |
| 12. Check wall outlet voltage and wiring | Make sure unit and wall outlet is wired properly. |

INSTRUCTIONS

IMPORTANT

If vehicle becomes stranded in the air, follow all operation instructions as shown on pages 31 - 36. If after observing that all mechanical locks are released and the lift still fails move following all standard operating procedures, immediately stop using the lift and contact factory or factory approved service center for further instructions.

LIFT WILL NOT STAY UP

POSSIBLE CAUSE

1. Air in oil, (1,2,3)
2. Check valve leaks, (6)
3. Cylinders leak internally, (7)
4. Lowering valve leaks, (4,5,1,7,6)
5. Leaking fittings, (8)

REMEDY

1. Check oil level

. The oil level should be up to the bleed screw in the reservoir with the lift all the way down.

2. Oil seal damaged and cocked Replace oil seal around pump shaft.

3. Bleed cylinder Refer to Installation Manual.

4. Flush release valve

. Hold release handle down and start unit allowing it to run for 15 seconds.

5. Replace with new valve Replace with new valve.





6. Return unit for repair Return unit for repair.

7. See Installation Manual Consult Lift Manufacturer.

8. Check complete hydraulic system for leaks. Tighten all hydraulics fittings and inspects all hoses.

INSTRUCTIONS

Torque Recommendations

VALUES ARE STATED IN FOOT POUNDS (ft-lb)					
					
		SAE 0-1-2	SAE Grade 5	SAE Grade 8	SOCKET HEAD CAP SCREW
		CLASS 4.8	CLASS 8.8	CLASS 10.9	CLASS 12.9
Bolt Size (SAE)	Bolt Size (Metric)				
1/4-20	M6 x 1.0	6	10	14	13
5/16-18	M8 x 1.25	12	19	29	31.4
3/8-16	M10 x 1.50	20	33	47	62
7/16-14		32	54	78	
1/2-13	M12 x 1.75	47	78	119	108
9/16-12	M14 x 2.00	69	114	169	173
5/8-11	M16 x 2.00	96	154	230	269
3/4-10	M18 x 2.50	155	257	380	372
7/8-9	M22 x 2.50	206	382	600	716
3/4 Anchor Bolts		75 MIN 110 MAX			

INSTALLATION FORM

Customer Name:		Date of Installation:
Company Name:		
Street Address:		
City:	State:	Zip:
Phone:	Fax:	

Pre-Install Agreement

I, (the undersigned) acting as the owner of the business listed above assume responsibility for any permits required, either state or county mandated, related to the installation and/or operation of this equipment. I assume responsibility for the concrete floor and condition thereof, now or later, where the above equipment model(s) are installed. I will assume all liability for losses, damages (including loss of use), expenses, demands, claims, and judgments in connection with or arising out of any personal injury or alleged damage to property, sustained or alleged to have been sustained in connection with, or to have arisen out of the condition and/or drilling of the concrete near or adjacent to the equipment model(s) listed above. If my employee(s) offer assistance of any kind during installation of the above equipment model(s) I hold the manufacturer and installation company harmless of all liability for losses, damages, expenses, claims, and judgments in connection with or arising out of any personal injury or alleged damage to property, sustained or alleged to have been sustained in connection with the installation of the above equipment model(s).

I understand that the lifts above are supplied with concrete fasteners meeting the criteria of the American National Standard "Automotive Lifts - Safety Requirements for Construction, Testing, and Validation" ANSI/ALI ALCTV-1998, and that I will be responsible for all charges related to any special regional structural and/or seismic anchoring requirements specified by any other agencies and/or codes such as the Uniform Building Code (UBC) and/or International Building Code (IBC).

Customer Signature: _____ Print Name: _____ Date: _____

Post-Installation Check-Off

- | | |
|--------------------------------------------------------------------------------------------------------------------------------------------------------------------------------------------------------------------------------------------------------------------------------------------------------------------------------------------------------------------------------------------------------------------------------------------------------------------------------|--------------------------------------------------------------------------------------------------------------------------------------------------------------------------------------------------------------------------------------------------------------------------------------------------------------------------------------------------------------------------------------------------------------------------------------------------------------------------------------------------------------|
| <input type="checkbox"/> Base and Columns Properly Shimmed And Stable
<input type="checkbox"/> Anchor Bolts Tightened
<input type="checkbox"/> Runways Properly Attached and Secured
<input type="checkbox"/> Electric Power Supply Confirmed
<input type="checkbox"/> Cables / Chains Adjusted Properly
<input type="checkbox"/> Safety Locks Functioning Properly
<input type="checkbox"/> Check For Hydraulic Leaks
<input type="checkbox"/> Oil Level | <input type="checkbox"/> Lubrication of Critical Components
<input type="checkbox"/> Lift Adapters
<input type="checkbox"/> Check For Overhead Obstructions
<input type="checkbox"/> Runways Level
<input type="checkbox"/> All Screws, Bolts, and Pins Secured
<input type="checkbox"/> Surrounding Area and Lift Clean In Appearance
<input type="checkbox"/> Proper Operation, Maintenance and Safety Explained
<input type="checkbox"/> Operation and Safety Manual(s) Left at Site |
|--------------------------------------------------------------------------------------------------------------------------------------------------------------------------------------------------------------------------------------------------------------------------------------------------------------------------------------------------------------------------------------------------------------------------------------------------------------------------------|--------------------------------------------------------------------------------------------------------------------------------------------------------------------------------------------------------------------------------------------------------------------------------------------------------------------------------------------------------------------------------------------------------------------------------------------------------------------------------------------------------------|

I, (the undersigned) confirm that the above installation procedure(s) were completed. I understand that I will be responsible for maintaining this equipment as outlined in the accompanied **Installation and Operation Manual** and **ANSI/ALI ALOIM Safety Requirements for Operation, Inspection and Maintenance**. I understand that personal injury and/or damage to property can occur if the above equipment model(s) are not maintained or used improperly and take full responsibility for training my employees on proper use and maintenance of this equipment. I hold the manufacturer and installation company harmless of all liability for losses, damages (including loss of use), expenses, demands, claims, and judgments in connection with or related to improper use, improper training, or lack of required maintenance. I understand that the warranty does not cover replacement of parts worn or damaged due to normal use or lack of required maintenance

Customer Signature: _____ Print Name: _____ Date: _____

Installer Signature: _____ Print Name: _____ Date: _____

Installer Company Name: _____

Street Address: _____

City: _____ State: _____ Zip: _____

Phone: _____ Phone (Other): _____

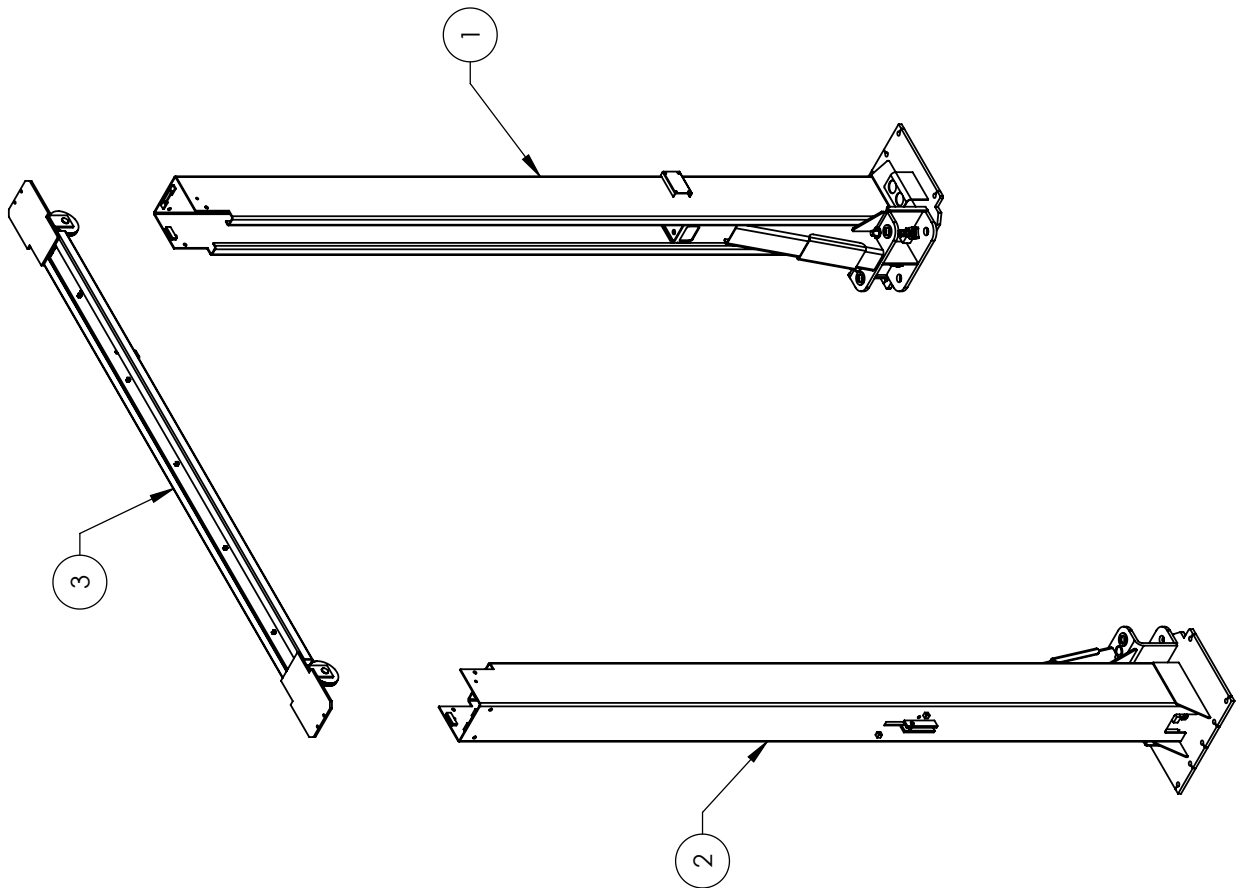

ITEM NO	PART NUMBER	DESCRIPTION	QTY	REV
1	5215293	XPR-12C POWER SIDE POST ASSEMBLY	1	V
2	5215292	XPR-12C OFF SIDE POST ASSEMBLY	1	V
3	5210031	XPR-12/15/18C TOP TROUGH ASSEMBLY	1	K

BendPak
 1645 LEMONWOOD DR.
 SANTA PAULA, CA 93060

TITLE: XPR-12C LIFT
 SUPERSTRUCTURE
 SIZE DWG. NO. 5245138
 REV W
 SCALE: 1:35
 SHEET 1 OF 1

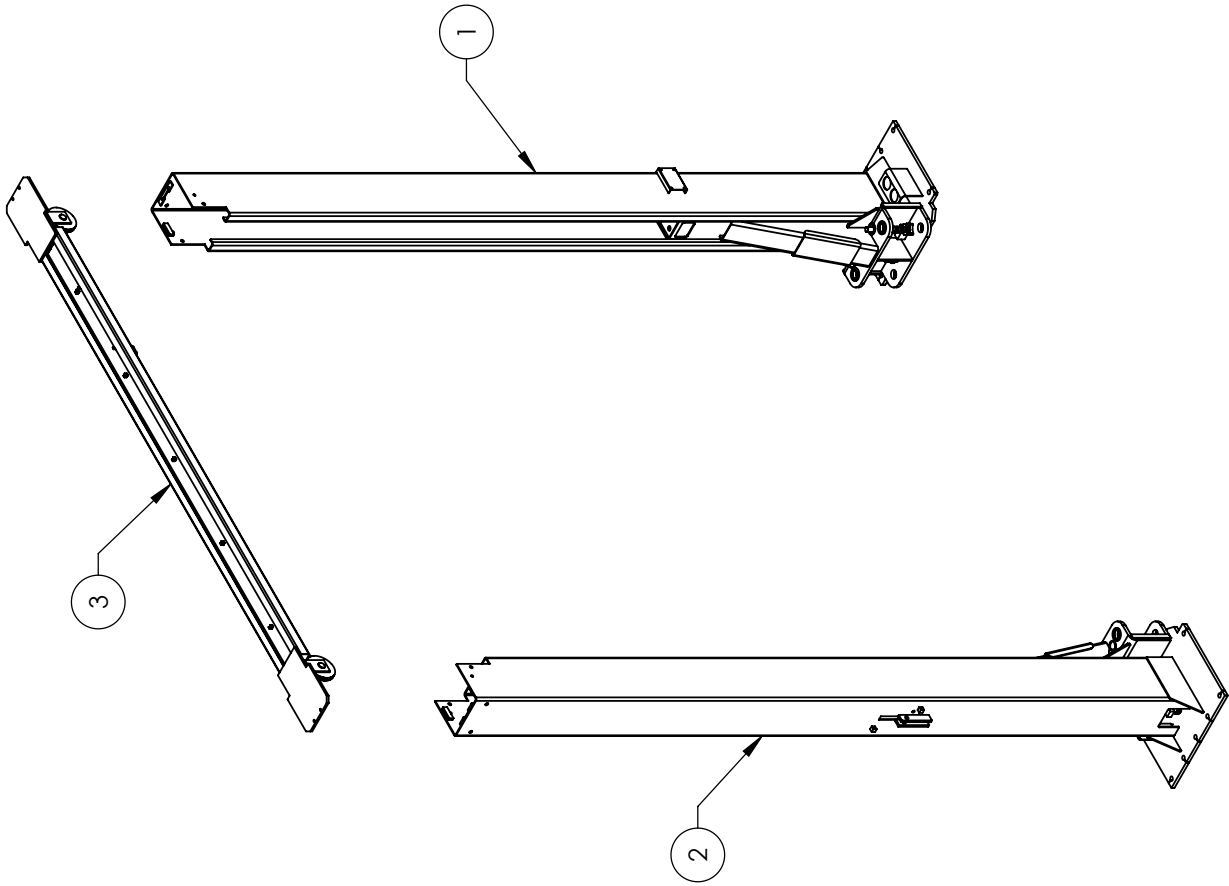

ITEM NO	PART NUMBER	DESCRIPTION	QTY	REV
1	5215218	XPR-15/18C POWER SIDE POST ASSEMBLY	1	V
2	5215216	XPR-15/18C OFF SIDE POST ASSEMBLY	1	V
3	5210031	XPR-12/15/18C TOP TROUGH ASSEMBLY	1	K

BendPak 1645 LEMONWOOD DR.
SANTA PAULA, CA 93060

TITLE: XPR-15/18C LIFT
SUPERSTRUCTURE

SIZE DWG. NO. A 5245139

REV W

SCALE: 1:35

SHEET 1 OF 1

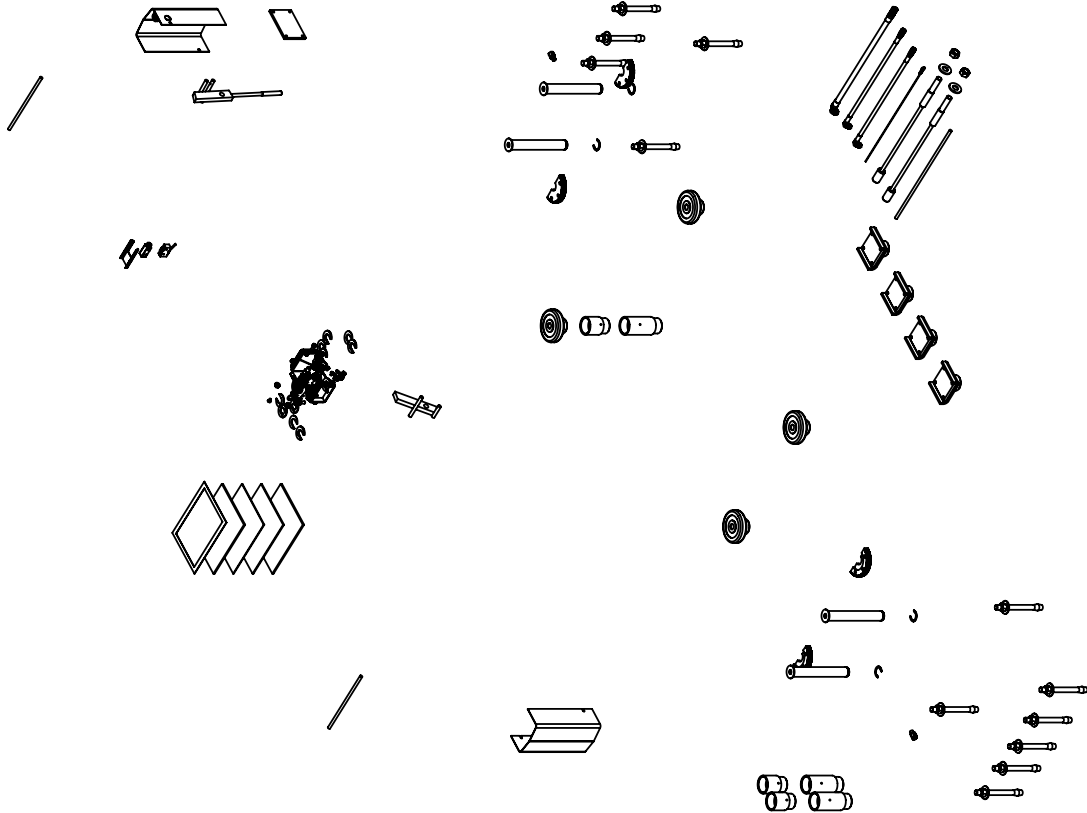

ITEM NO.	PART NUMBER	DESCRIPTION	QTY	REV
1	5174518	XPR CLEARFLOOR PARTS BAG	1	J
2	5733603	XPR-12 BOLT ON ARM RESTRAINT GEAR	4	L
3	5746192	ARM ADAPTER MEDIUM	4	C
4	5746193	ARM ADAPTER LONG	4	B
5	5210009	XPR-9D/10/12/15/18C OFF-SIDE SAFETY COVER	4	E
6	5600163	XPR CLEARFLOOR POWER SIDE SAFETY COVER	4	E
7	5215701	ROUND LIFT PAD ADAPTER ASSEMBLY	4	A
8	5715003	POWER UNIT VIBRATION DAMPENER	1	E
9	5210010	XPR OFF-SIDE SAFETY WELDMENT	1	E
10	5210007	XPR POWER SIDE SAFETY ASSEMBLY	4	B
11	5505346	XPR-12C/FD LIFT HEAD PIN WELDMENT	4	B
12	5570150	XPR-12C/15/18C HYDRAULIC HOSE ASSY Ø6.35 x 9611mm SB	1	D
13	5570017	XPR HYDRAULIC HOSE ASSY Ø10 x 1219mm SB	1	C
14	5570832	XPR CLEARFLOOR HYDRAULIC HOSE ASSY Ø6.35 x 22997mm SB	1	E
15	5595125	XPR-12C/15/18C Ø2.4mm x 5900 SAFETY CABLE	1	B
16	5595922	XPR-12C/15/18C7 XPR-12C-LWB CABLE ASSY Ø12 x 10640mm ST	2	A
17	5535011	NUT M22 x 2.5 NL	2	-
18	5545345	WASHER M22 x 50mm FLAT	2	-
19	5540281	C-RING Ø38mm OD 5103-150	4	-
20	5746166	DOUBLE THREADED ROD M10 x 1.5 x 295	2	B
21	5525150	SPDT MICRO SWITCH 25A @ 125VAC	1	-
22	5520116	14-4510 UL-67 CABLE 300V/C	4275mm*	-
23	5525119	MICRO SWITCH COVER SPAS	4	A
24	5742124	XPR MICRO SWITCH COVER PLASTIC	4	B
25	5216604	CRADLE LIFT PAD LIFT COUPLER ASSEMBLY	14	-
26	5530308	FIG NPL-04 NPLX-04 FNPT	2	-
27	5550112	ALIGN OIM OPERATION INSPECTION & MAINTENANCE	1	-
28	5900280	SAFETY TIPS CARD ALL SM 93-1	1	-
29	5900152	SAFETY TIPS CARD ALL SM 93-1	1	-
30	5900147	SAFETY TIPS CARD ALL SM 93-1	1	-
31	5905151	XPR-12C-18 INSTALLATION MANUAL	1	-
32	5900224	XPR-12C-18 INSTALLATION MANUAL	1	-



TITLE: XPR-12CL/12CL-LWB
PARTS BOX

SIZE	DWG. NO.	REV
A	5250041	A

SCALE: 1:28 SHEET 1 OF 2

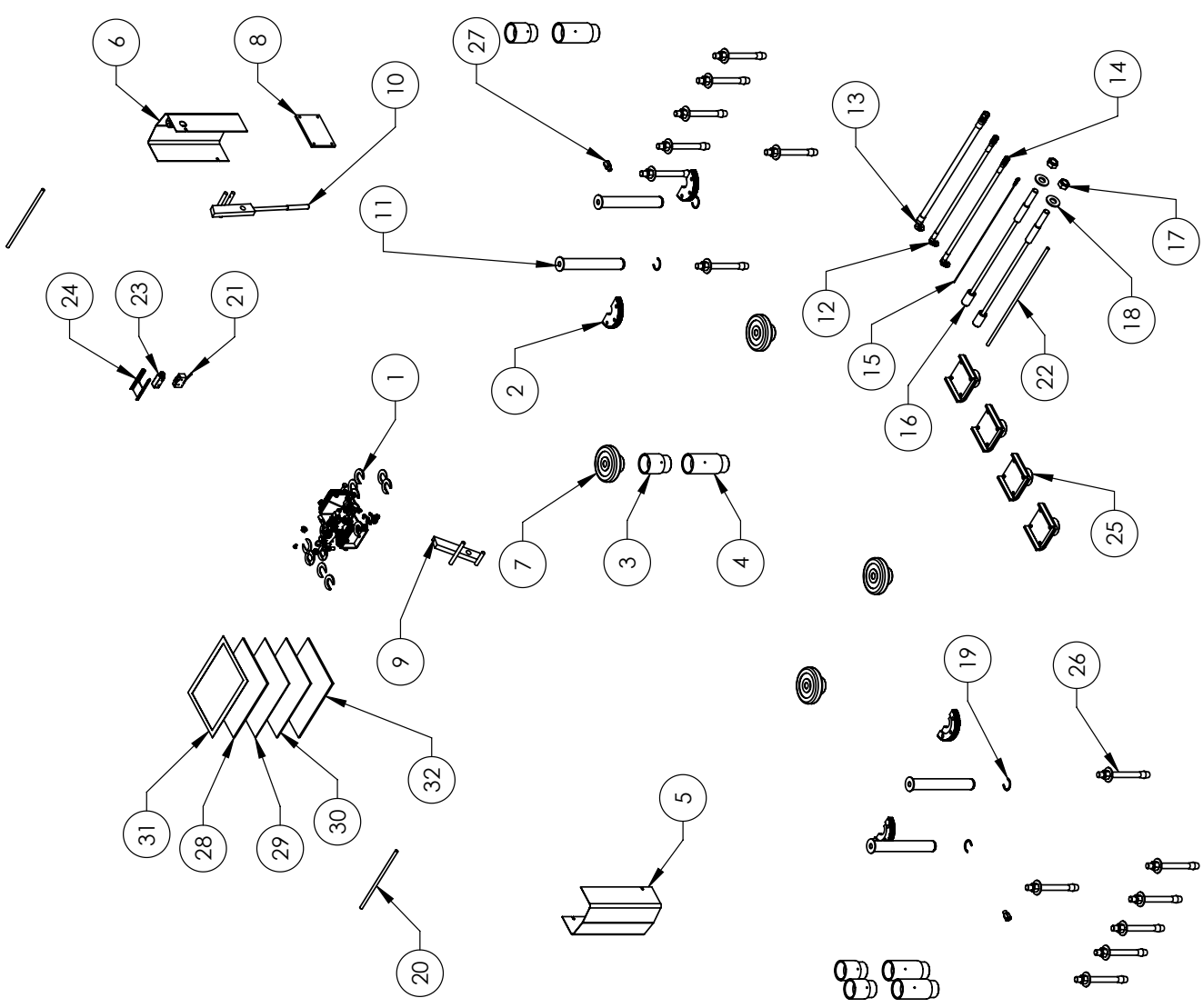

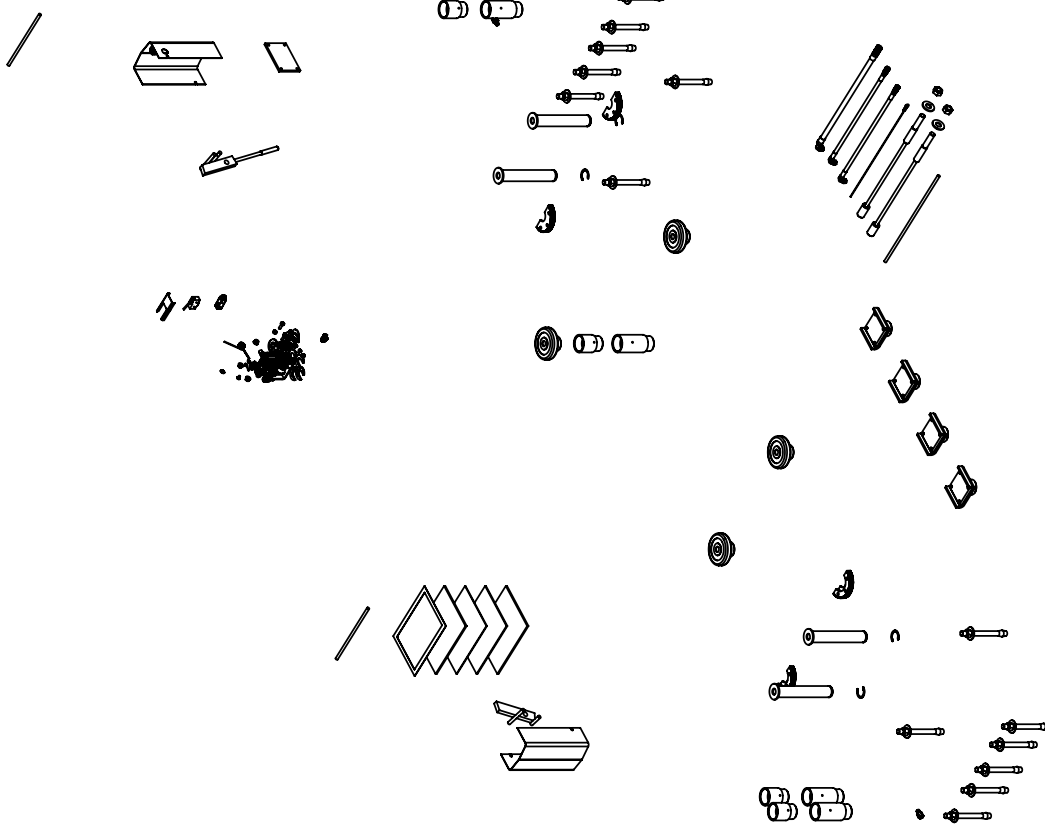

ITEM NO.	PART NUMBER	DESCRIPTION	QTY	REV
1	5174516	XPR CLEARFLOOR PARTS BAG	1	J
2	5736606	XPR-15/18 BOLT ON ARM RESTRAINT GEAR	4	F
3	5746192	ARM ADAPTER, MEDIUM	4	C
4	5746193	ARM ADAPTER, LONG	4	B
5	5210009	XPR-9/D/10/12/15/18C OFF SIDE SAFETY COVER	1	E
6	5600163	XPR CLEARFLOOR POWER SIDE SAFETY COVER	1	E
7	5215701	ROUND LIFT PAD ADAPTER ASSEMBLY	4	A
8	5715003	POWER UNIT VIBRATION DAMPENER	1	B
9	5210010	XPR OFF SIDE SAFETY WELDMEN	1	F
10	5210007	XPR POWER SIDE SAFETY ASSEMBLY	1	F
11	5600349	XPR-15/18C LIFT HEAD PIN WELDMENT	4	C
12	5570150	XPR-12C/15/18C HYDRAULIC HOSE ASSY Ø6.35 x 9611mm SB	1	D
13	5570017	XPR HYDRAULIC HOSE ASSY Ø10 x 1219mm SB	1	C
14	5570832	XPR CLEARFLOOR HYDRAULIC HOSE ASSY Ø6.35 x 2299mm SB	1	E
15	5595125	XPR-12C/15/18C Ø2.4mm x.8900 SAFETY CABLE	1	B
16	5595922	XPR-12C/15/18C/7 XPR-12C-LWB CABLE ASSY Ø12 x 10640mm ST	2	A
17	5535011	NUT M22 x 2.5 NL	2	-
18	5545345	WASHER M22 x 50mm FLAT	2	-
19	5540112	SNAP RING: TRUARC 5103-175	4	-
20	5746166	DOUBLE THREADED ROD M10 x 1.5 x 29.5	2	B
21	5716634	XPR MICRO SWITCH COVER, PLASTIC	1	A
22	5530308	AR 3/4" x 7"	14	-
23	5550112	FIG NPL -04 NPT X-04 F NPT	2	-
24	5520116	14-4 S TO UI -02 CABLE 300VQC	4275mm*	-
25	5525150	SPDT MICRO SWITCH 25A @ 125VAC	1	-
26	5915102	MICRO SWITCH COVER 5P2	1	-
27	5915102	GRADLE LIFT PAD LARGE ADAPTER ASSEMBLY	4	B
28	5900224	XPR-12C/18 INSGATE ALION MA ASSEMBLY	1	-
29	5905154	SAFETY LIFT CARD ALION MA	1	-
30	5900147	SAFETY LIFT CARD ALI 931	1	-
31	5900152	ALIGN OIM OPERATION INSPECTION & MAINTENANCE	1	-
32	59200280	ALI/TP FRAME ENGAGING LIFTS GUIDE	1	-

1645 LEMONWOOD DR.
SANTA PAULA, CA 93660



TITLE: XPR-15CL PARTS BOX

SIZE DWG. NO. A 5250043

SCALE: 1:28

REV A

SHEET 1 OF 2

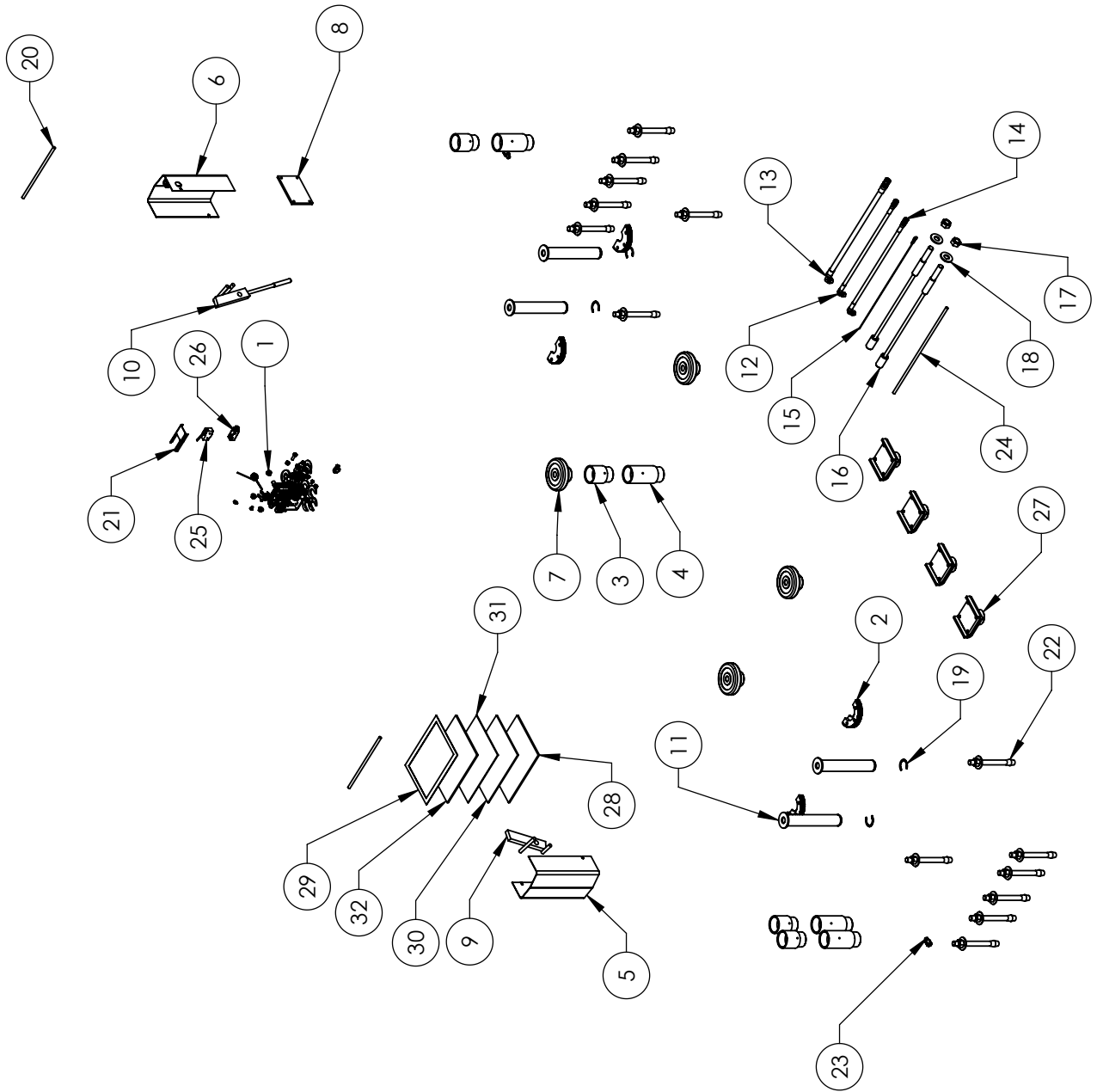

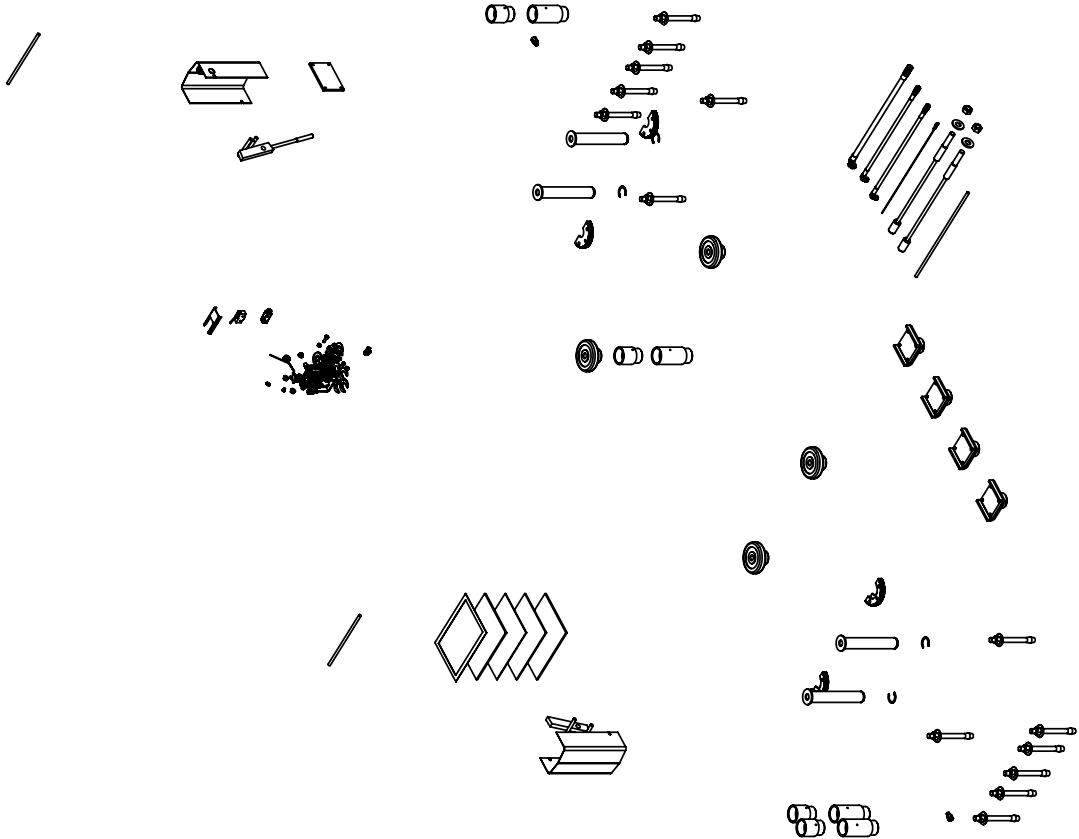

ITEM NO	PART NUMBER	DESCRIPTION	QTY	REV
1	574518	XPR CLEARFLOOR PARTS BAG	1	J
2	573606	XPR-15/18 BOLT ON ARM RESTRAINT GEAR	4	F
3	5746192	ARM ADAPTER MEDIUM	4	C
4	5746193	ARM ADAPTER LONG	4	C
5	5210009	XPR-9D/10/12/12ED/15/18C OFF SIDE SAFETY COVER	1	E
6	5600163	XPR CLEARFLOOR POWER SIDE SAFETY COVER	1	A
7	52115701	ROUND LIFT PAD ADAPTER ASSEMBLY	4	A
8	5715003	POWER UNIT VIBRATION DAMPENER	1	B
9	5210010	XPR OFF SIDE SAFETY WELDMENT	1	F
10	5210007	XPR POWER SIDE SAFETY ASSEMBLY	1	F
11	5600349	XPR-15/18C LIFT HEAD PIN WELDMENT	4	C
12	5570150	XPR-12C/15/18C HYDRAULIC HOSE ASSY Ø6.35 x 9.611mm SB	1	D
13	5570017	XPR HYDRAULIC HOSE ASSY Ø10 x 1219mm SB	1	C
14	5570832	XPR CLEARFLOOR HYDRAULIC HOSE ASSY Ø6.35 x 299mm SB	1	E
15	5595125	XPR-12C/15/18C Ø2.4mm x 8900 SAFETY CABLE	1	B
16	5595922	XPR-12C/15/18C/12C-LWB CABLE ASSY Ø12 x 10640mm ST	2	A
17	5535011	NUT M22 x 2.5 NI	2	-
18	5545345	WASHER M22 x 50mm FLAT	2	-
19	5540112	SNAP RING-TIRUARC-5103-17/5	4	-
20	5746166	DOUBLE THREADED ROD M10 X 1.5 X 295	2	B
21	5716634	XPR MICRO SWITCH COVER PLASTIC	1	A
22	5530308	AB 374 x 7	14	-
23	5530112	FIG NPL -04 NPLX -04 F NPT	2	-
24	5520116	14-4 SJOU L62 CABLE 300VGC	4275mm*	-
25	5525150	SPDI MICRO SWITCH-25A@125VAC	1	-
26	5525112	MICRO SWITCH COVER 5PAZ	1	-
27	5215702	CRADLE LIFT PAD LARGE ADAPTER ASSEMBLY	4	B
28	5900924	XPR-12C-18 INSTALLATION MANUAL	1	-
29	5905151	SAFETY TIPS CARD ALL ST 90	1	-
30	5900147	SAFETY MANUAL ALL SM 93-1	1	-
31	5900152	ALIGN OIM OPERATION INSPECTION & MAINTENANCE	1	-
32	5900280	ALI/ZIP FRAME ENGAGING LIFTS GUIDE	1	-

BendPak
 1645 LEMONWOOD DR.
 SANTA PAULA, CA 93060

TITLE: XPR-18CL PARTS BOX

SIZE DWG. NO. **A** 5250044

REV **A**

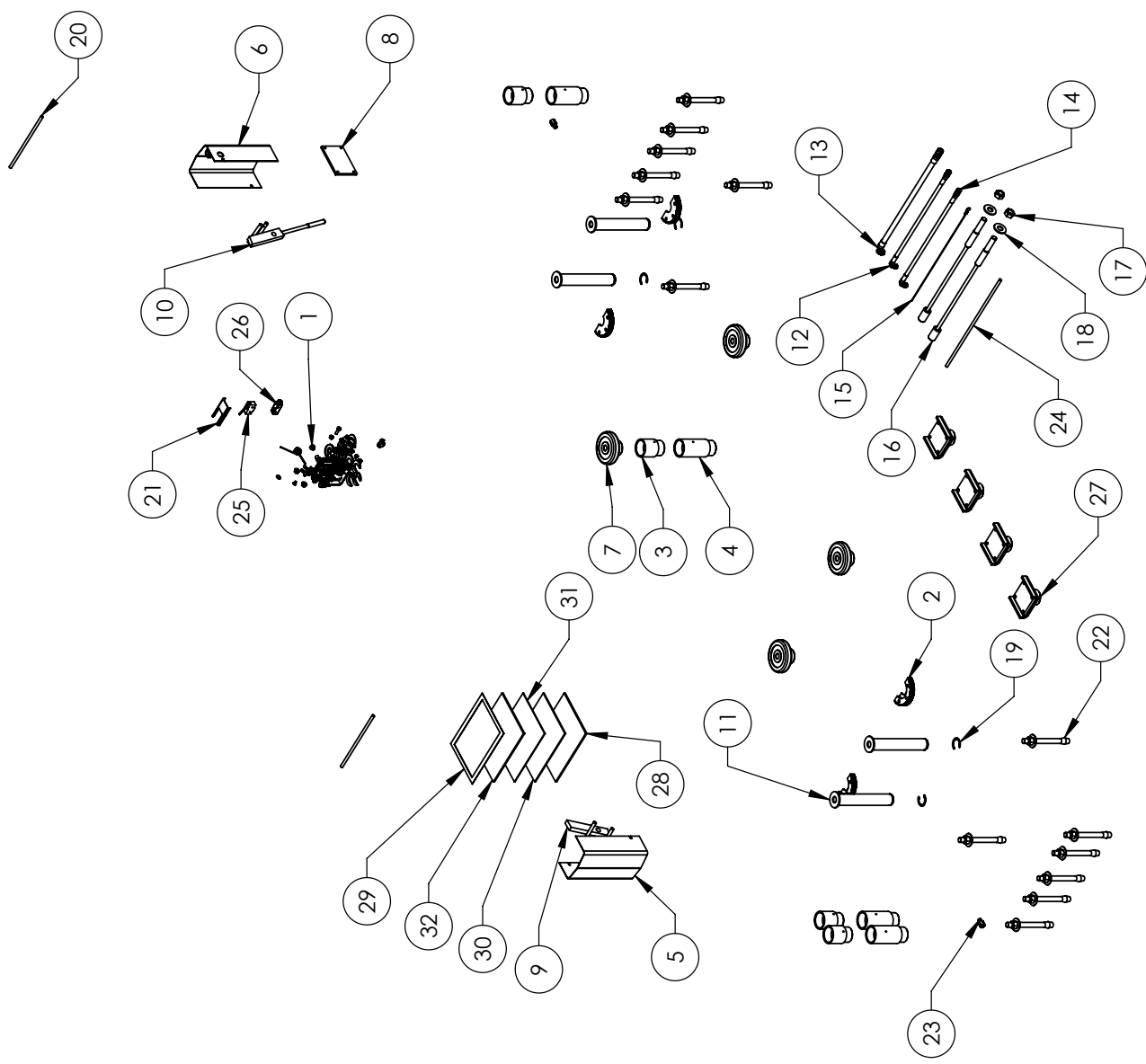

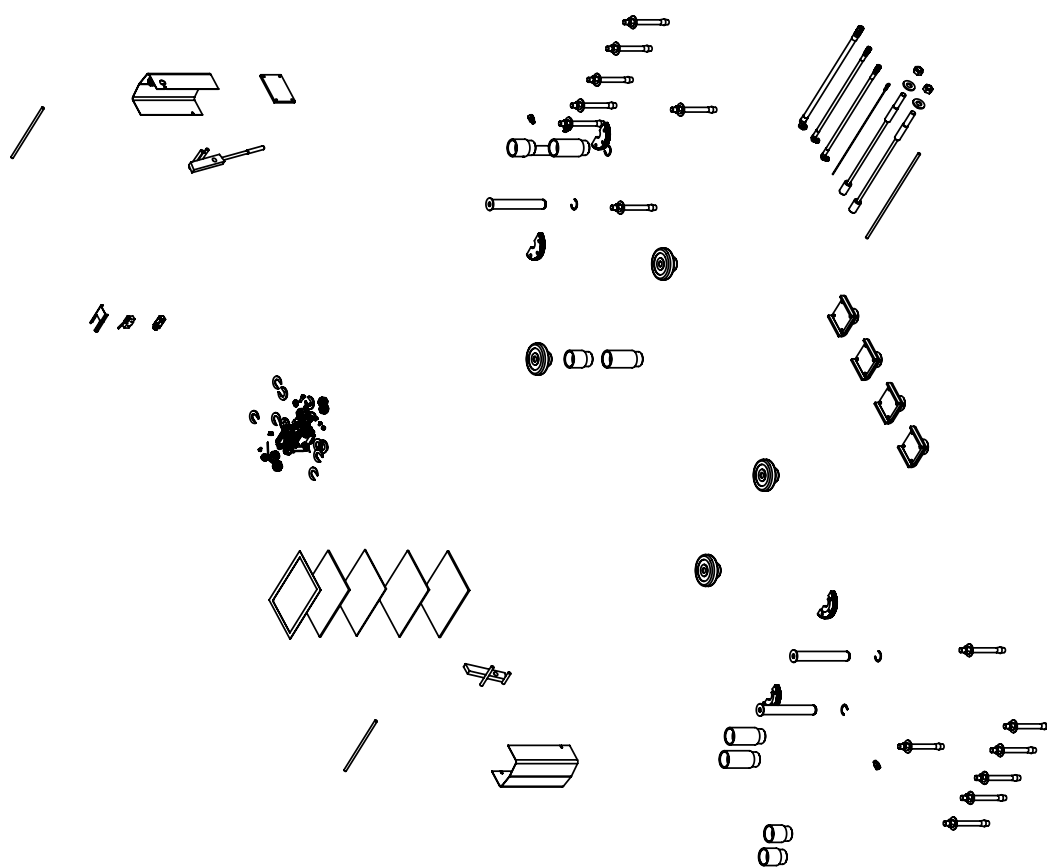

ITEM NO	PART NUMBER	DESCRIPTION	QTY	REV
1	574218	XPR CLEARFLOOR EXTENDED PARTS BAG	1	J
2	5736605	XPR-12C ROLL ON ARM RESTRAINT GEAR	4	E
3	5746192	ARM ADAPTER MEDIUM	4	C
4	5746193	ARM ADAPTER LONG	4	B
5	5710009	XPR-12C/15/18C OFF SIDE SAFETY COVER	1	L
6	5700163	XPR CLEARFLOOR POWER SIDE SAFETY COVER	1	L
7	5915701	POUND LIFT PAD ADAPTER ASSEMBLY	4	A
8	5715003	POWER UNIT VIBRATION DAMPER	4	A
9	5710010	XPR OFF SIDE SAFETY COVER	1	L
10	5710007	XPR POWER SIDE SAFETY COVER	1	L
11	5505346	XPR-12C/15/18C LIFT HEAD WELDMENT	4	B
12	5570008	XPR-12C/15/18C/ XPR-12C-LWB EXTENDED HYDRAULIC HOSE ASSY Ø6.35 x 1.0833mm SB	1	B
13	5570017	XPR HYDRAULIC HOSE ASSY Ø10 x 1.219mm SB	1	C
14	5570832	XPR CLEARFLOOR HYDRAULIC HOSE ASSY Ø6.35 x 2.299mm SB	1	E
15	5595106	XPR-12C/15/18C/ XPR-12C-LWB EXTENDED Ø2.4 X 10109 SAFETY CABLE	1	A
16	5595617	XPR-12C/15/18C/ XPR-12C-LWB EXTENDED CABLE ASSY Ø12 x 1.1849mm ST	2	A
17	5535011	NUT M22 x 2.5 NL	2	-
18	5545345	WASHER M22 x 50mm FLAT	2	-
19	5540281	C RING Ø38mm OD 5103-150	4	-
20	5746166	DOUBLE THREADED ROD M10 X 1.5 X 295	2	B
21	5716634	XPR MICRO SWITCH COVER PLASTIC AB 3/4" x 7/8"	1	A
22	5530308	14-4 SJO UL 62 CABLE 300VGG	14	-
23	5520116	SPDT MICRO SWITCH 25A@125VAC	4885mm*	-
24	5525150	FIG NPL -04 NPL -04 F NPT	1	A
25	5550112	MICRO SWITCH COVER 5PA2	2	-
26	5525112	MICRO SWITCH COVER 5PA2	1	-
27	5215702	GRADLE LIFT PAD LARGE ADAPTER ASSEMBLY	4	B
28	5900224	XPR-12C-18 INSTALLATION MANUAL	1	-
29	5905151	SAFETY TIPS CARD ALL ST 90	1	-
30	5900147	SAFETY MANUAL ALL SM 93-1	1	-
31	5900152	ALIGN/OM OPERATION INSPECTION & MAINTENANCE	1	-
32	5900280	ALI/P FRAME ENGAGING LIFTS GUIDE	1	-



 1645 LEMONWOOD DR.
 SANTA PAULA, CA 93060

TITLE: XPR-12C/12CL-LWB
 EXTENDED PARTS BOX

SIZE DWG. NO. **A** 5250045 REV **A**

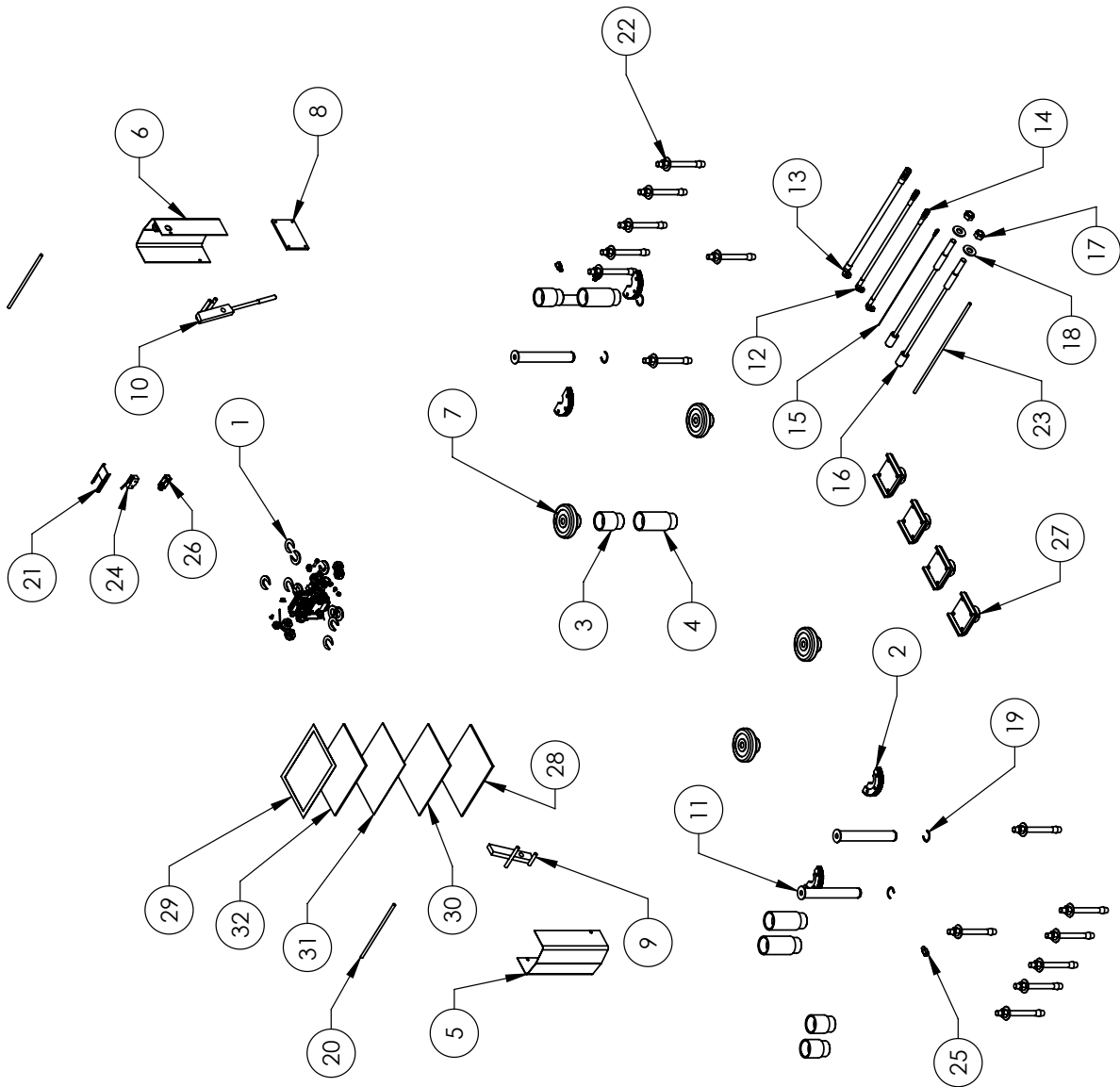
SCALE: 1:28 SHEET 1 OF 2

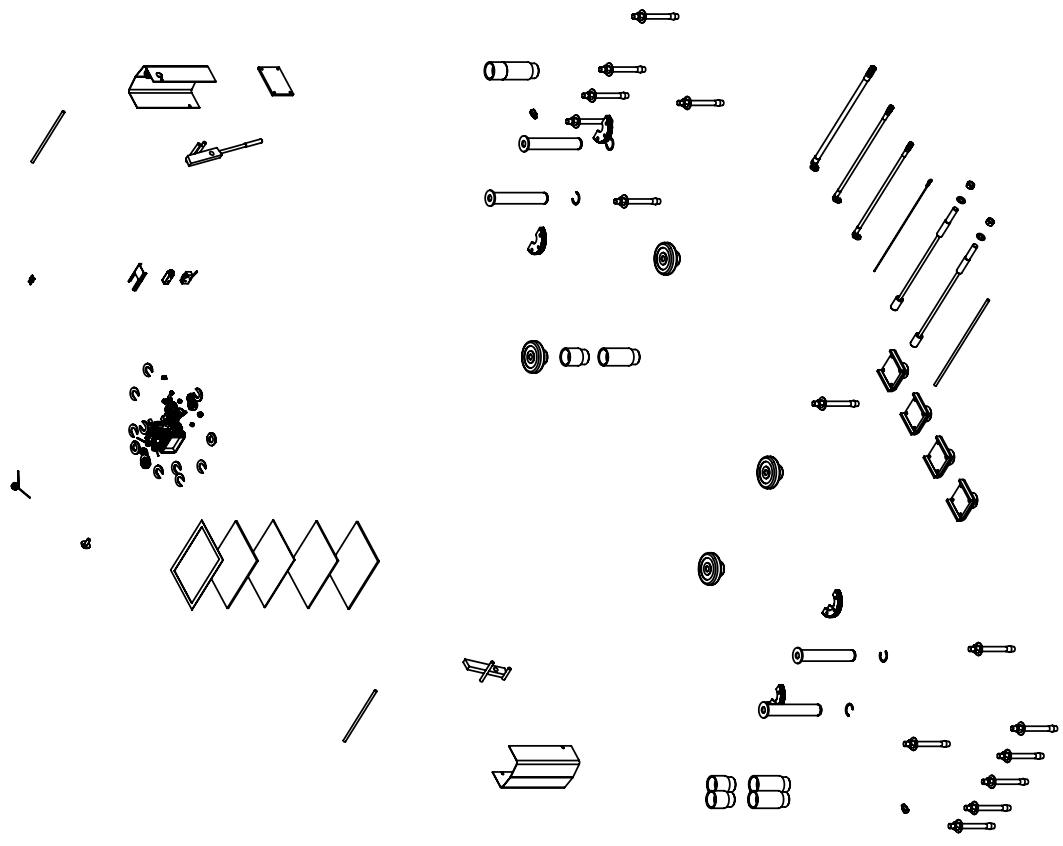



ITEM NO	PART NUMBER	DESCRIPTION	QTY	REV
1	5174218	XPR CLEARFLOOR EXTENDED PARTS BAG	1	J
2	5736606	XPR-15/18 BOLT ON ARM RESTRAINT GEAR	4	F
3	5736609	ARM ADAPTER MEDIUM	4	C
4	5746183	ARM ADAPTER MEDIUM	4	-
5	5210029	XPR-9D/10/12/15/17/18/20 OFF-SIDE SAFETY COVER	1	E
6	5210029	XPR CLEARFLOOR LOWER SIDE SAFETY COVER	1	E
7	5210029	ROUND LIFT PAD ADAPTER ASSEMBLY	4	A
8	5215701	CRADLE LIFT PAD LARG ADAPTER ASSEMBLY	4	B
9	5715003	POWER UNIT VIBRATION DAMPENER	1	B
10	5210010	XPR OFF-SIDE SAFETY WELDMENT	1	E
11	5210007	XPR POWER SIDE SAFETY ASSEMBLY	1	F
12	5600349	XPR-15/18C LIFT HEAD PIN WELDMENT	4	C
13	5570008	XPR-12C/15/18C / XPR-12C-LWB EXTENDED	1	B
14	5570017	HYDRAULIC HOSE ASSY Ø6.35 x 10833mm SB	1	C
15	5570832	XPR HYDRAULIC HOSE ASSY Ø10 x 1219mm SB	1	E
16	5595106	XPR-12C/15/18C / XPR-12C-LWB EXTENDED Ø2.4 X 10109 SAFETY CABLE	1	A
17	5595617	XPR-12C/15/18C / XPR-12C-LWB EXTENDED CABLE ASSY Ø12 x 11849mm ST	2	A
18	5535358	NUT M18 x 2.5 NL	2	-
19	5545342	WASHER M18 FLAT	2	-
20	5540112	SNAP RING-TRUARC 5103-175	4	-
21	5716634	XPR MICRO SWITCH COVER-PLASTIC	2	A
22	5746166	DOUBLE THREADED ROD M10 x 1.5 x 295 AB 3/4" x 7"	2	B
23	5530308	14-4 SJO UL 62 CABLE 300VVC 4885mm*	14	-
24	5520116	SPDT MICRO SWITCH 25A@125VAC	2	-
25	5525150	FIG NPL-04 NPL x 04 NPL	2	-
26	5550112	MICRO SWITCH COVER-5P2	2	-
27	5590022	XPR-12C-18 INSTALLATION MANUAL	1	-
28	5900224	SAFETY TIPS CARD ALI-ST 90	1	-
29	5905151	SAFETY MANUAL ALI / SM 93-1	1	-
30	5900147	ALIGN OIM OPERATION INSPECTION & MAINTENANCE	1	-
31	5900152	ALIGN OIM OPERATION INSPECTION & MAINTENANCE	1	-
32	5900280	ALI/TP FRAME-ENGAGING LIFTS GUIDE	1	-

BendPak 1645 LEMONWOOD DR.
SANTA PAULA, CA 93060

TITLE: XPR-15CL EXTENDED PARTS BOX

SIZE DWG. NO. **A** 5250046 REV **A**

SCALE: 1:28 SHEET 1 OF 2

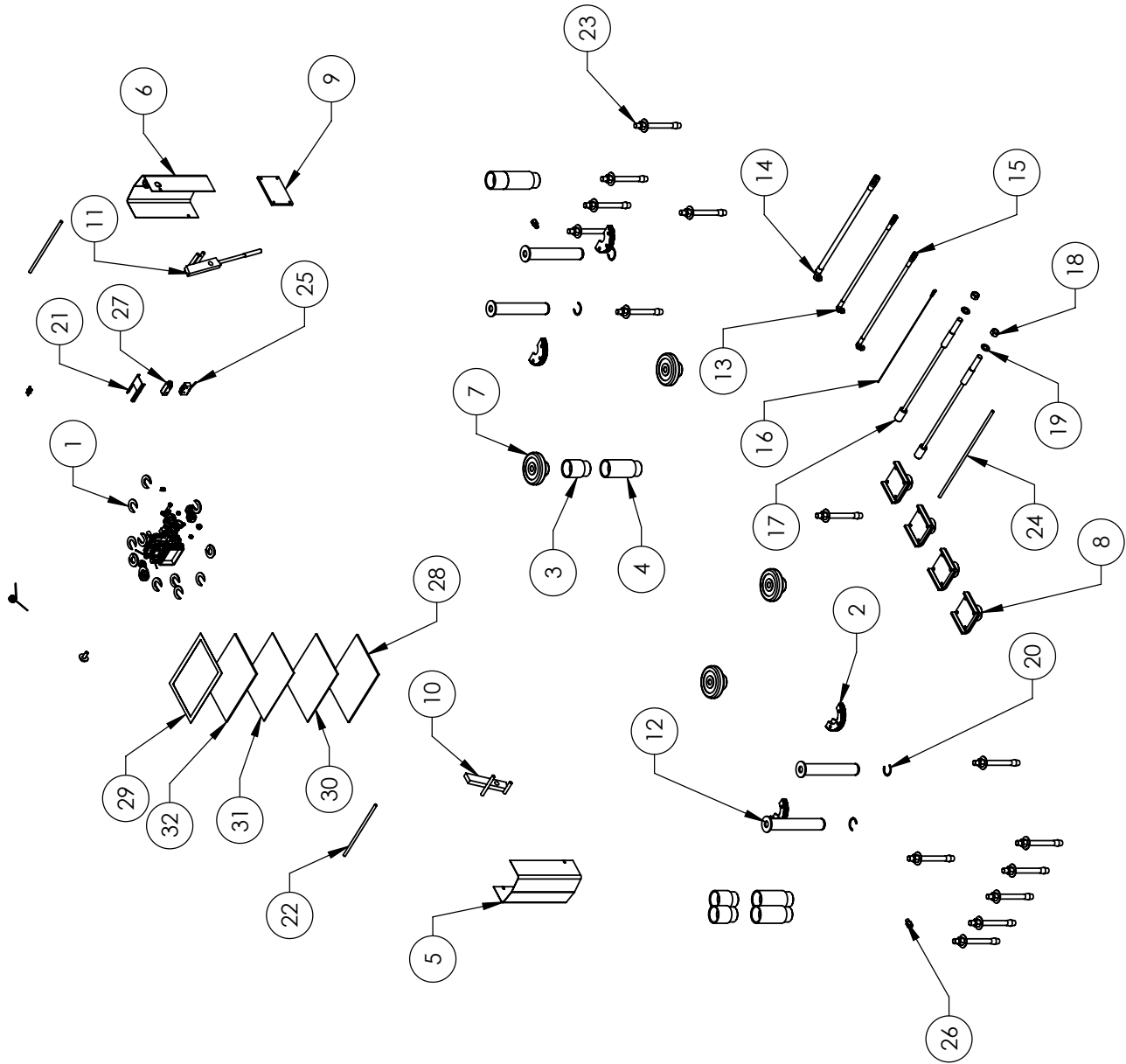

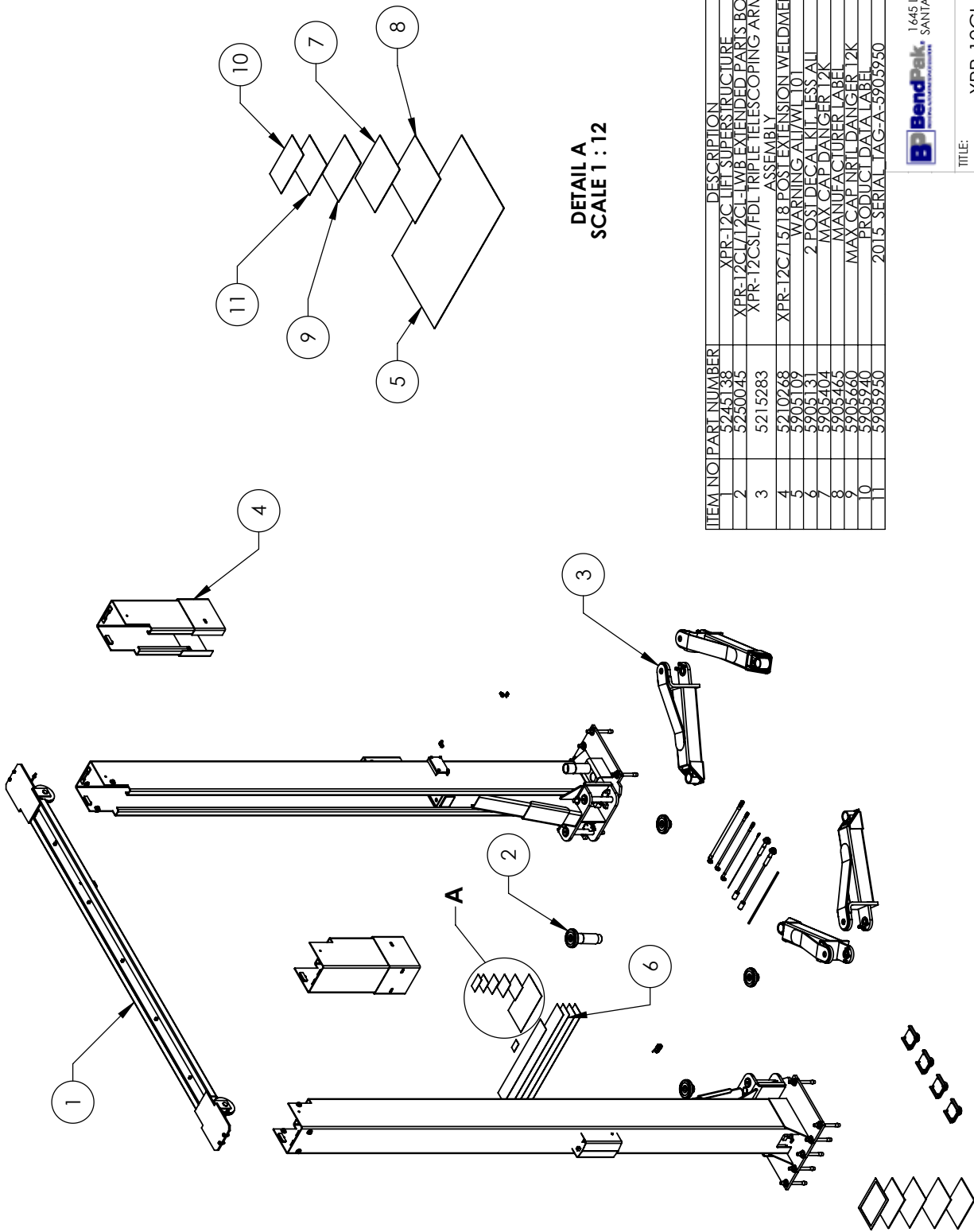

DETAIL A
SCALE 1 : 12

ITEM NO	PART NUMBER	DESCRIPTION	QTY	REV
1	5245138	XPR-12CL LIFT SUPERSTRUCTURE	1	W
2	5250045	XPR-12CL/12CL-LWB EXTENDED PARTS BOX	1	A
3	5215283	XPR-12CL/FDL TRIPLE TELESCOPING ARM	4	C
4	5210268	XPR-12CL/15/18 POST EXTENSION WELDMENT	2	C
5	5905109	WARNING ALI FWL 101	1	C
6	5905131	2 POST DECK KIT LESS ALL	1	C
7	5905404	MAX CAP DANGER 12K	1	-
8	5905465	MANUFACTURER LABEL	1	-
9	5905660	MAX CAP NR1 DANGER 12K	1	-
10	5905940	PRODUCT DATA LABEL	1	-
11	5905950	2015 SERIAL TAG-A-5905950	1	-

BendPak
1645 LEMONWOOD DR.
SANTA PAULA, CA 93060

TITLE: XPR-12CL-192
PRODUCTION LIFT VER E

SIZE DWG. NO. 5260563
REV A

SCALE: 1:40 SHEET 1 OF 2

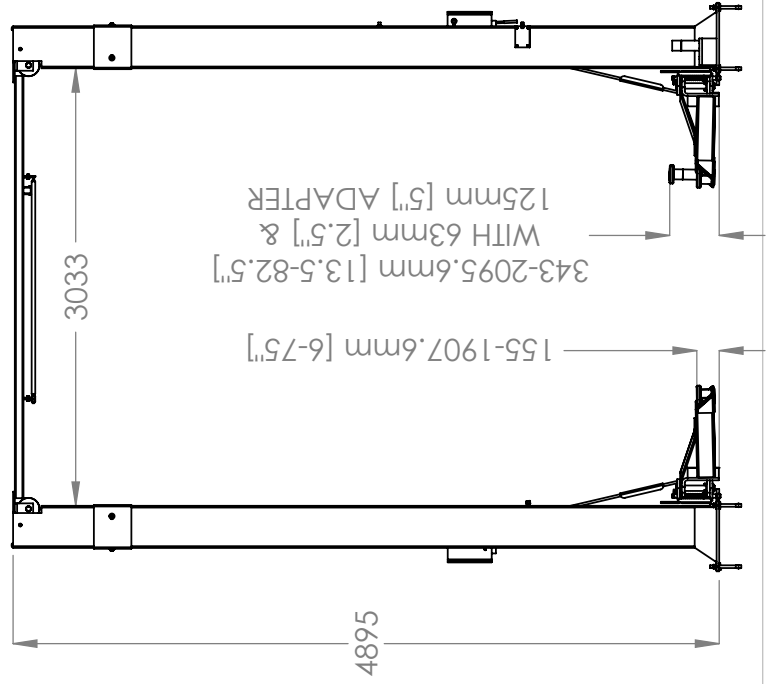
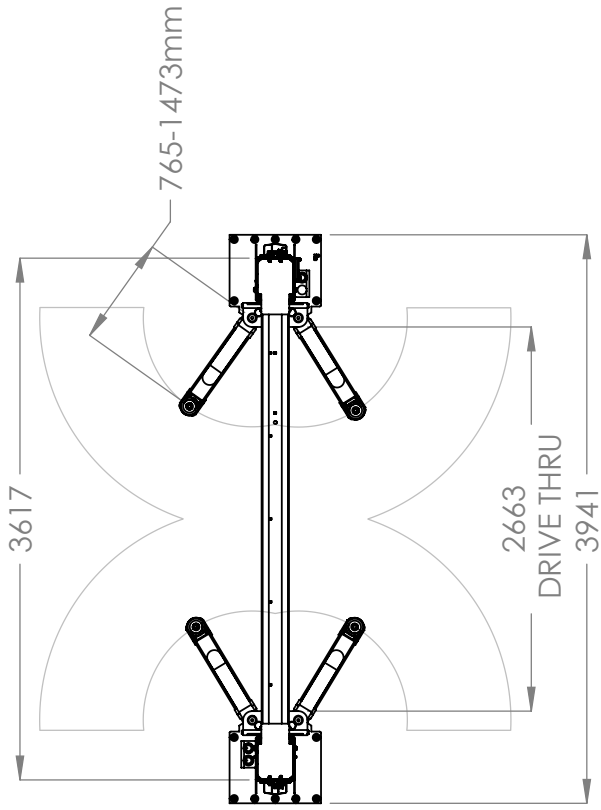

BendPak 1645 LEMONWOOD DR.
SANTA PAULA, CA 93060

TITLE:	XPR-12CL-192 PRODUCTION LIFT VER E	
SIZE DWG. NO.	5260563	REV A

SCALE: 1:50 SHEET 2 OF 2

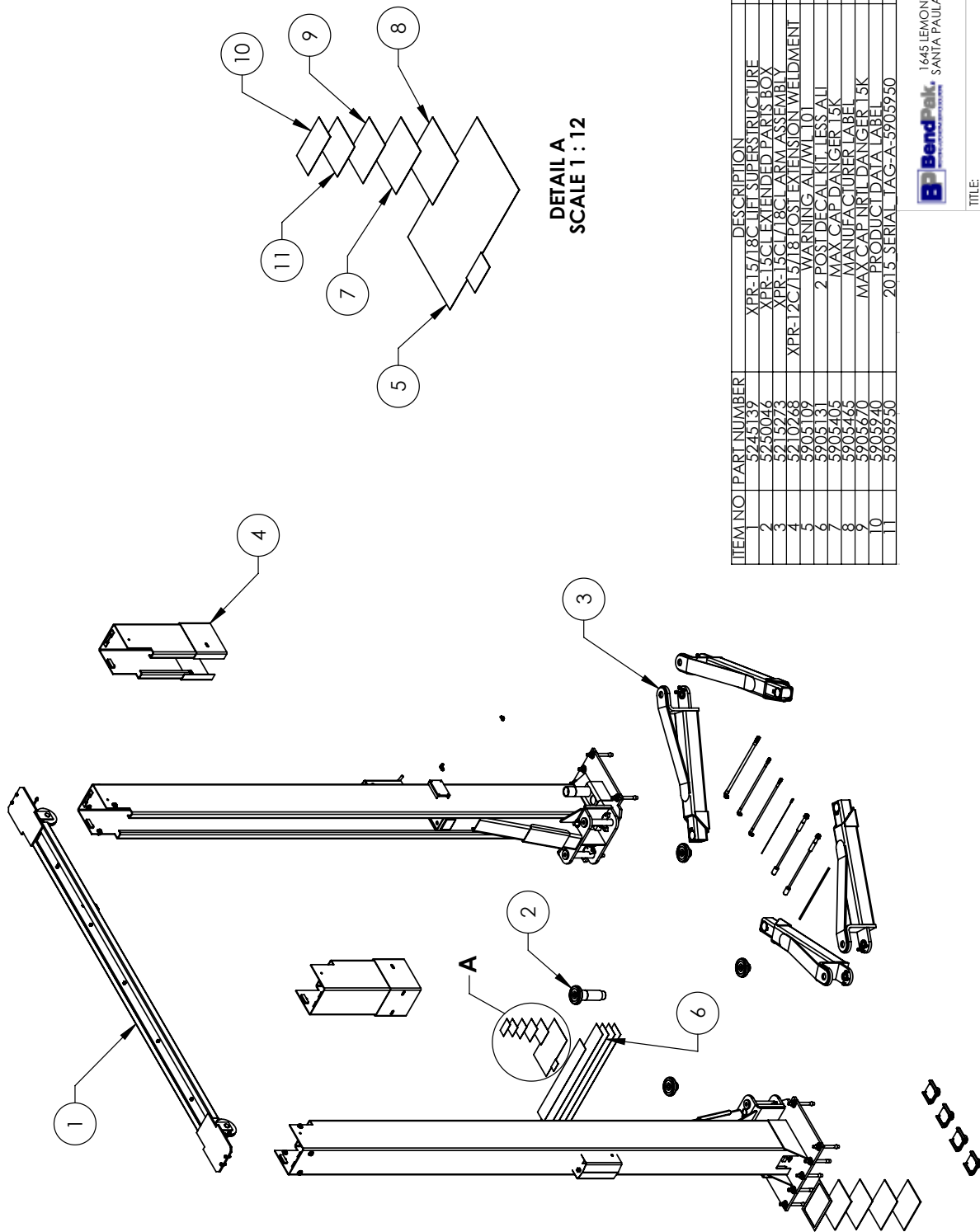

DETAIL A
SCALE 1 : 12

ITEM NO	PART NUMBER	DESCRIPTION	QTY	REV
1	5245139	XPR-15/18 CLUT SUPERSTRUCTURE	1	W
2	5250476	XPR-15CL EXTENDED PAPER BOX	1	A
3	5215976	XPR-15CL 178CL DRIVE ASSEMBLY	4	C
4	5210768	XPR-15/18 65CL DRIVE ASSEMBLY	4	C
5	3001768	XPR-12C/15/18 65CL FATISSION WELDMENT	2	C
6	5205107	WARNING LABEL	1	-
7	5205131	2 POST DECAL KILLS ALL	1	C
8	5205405	MAX CAP DANGER 15K	1	-
9	5205465	MANUFACTURER LABEL	1	-
10	5205670	MAX CAP INRL DANGER 15K	1	-
11	5205940	PRODUCT DATA LABEL	1	-
11	5205950	2013 SERIAL TAG-A-5205950	1	-

BendPak
1645 LEMONWOOD DR.
SANTA PAULA, CA 93060

TITLE: XPR-15CL-192
PRODUCTION LIFT VER E
SIZE DWG. NO. A 5260564
REV A

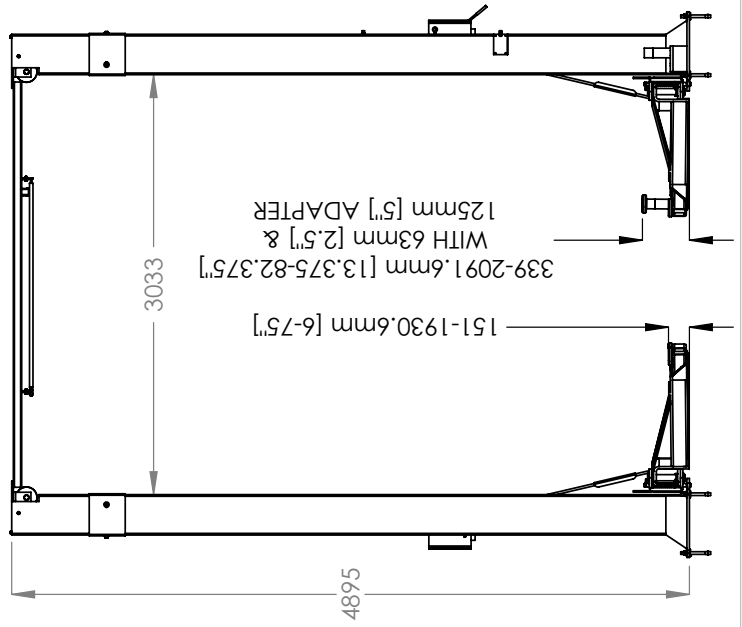
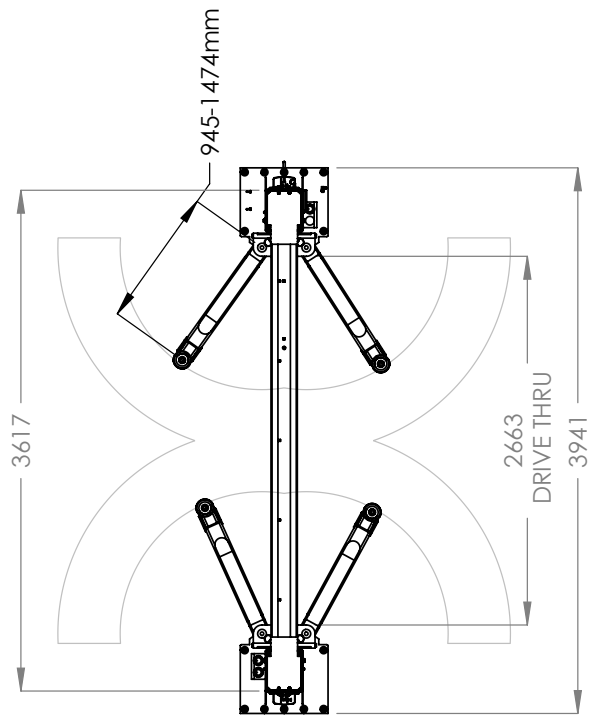

Bend-Pak
1645 LEMONWOOD DR.
SANTA PAULA, CA 93060

TITLE:	XPR-15CL-192 PRODUCTION LIFT VER E	
SIZE DWG. NO.	5260564	REV
A		A

SCALE: 1:50 SHEET 2 OF 2

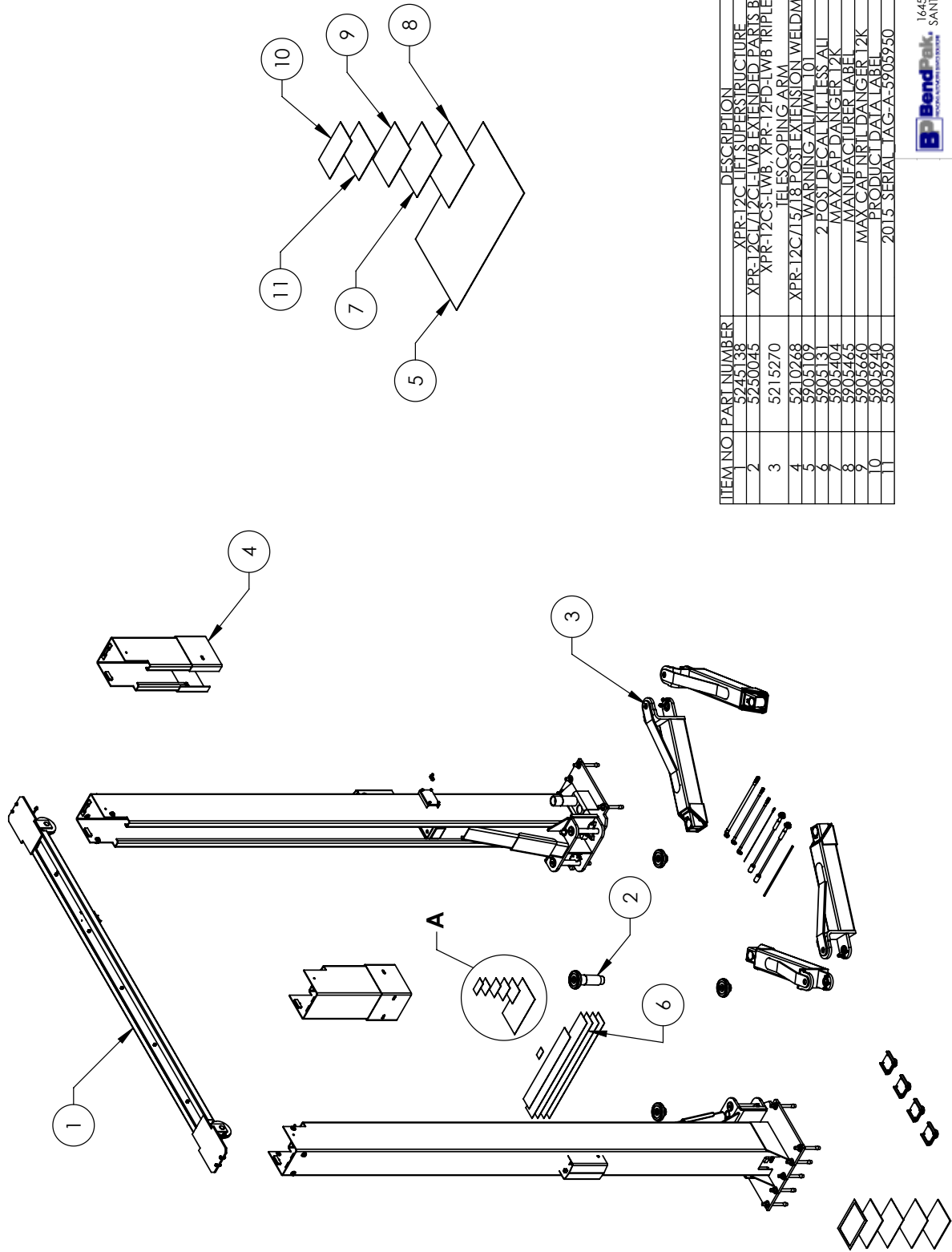

ITEM NO	PART NUMBER	DESCRIPTION	QTY	REV
1	5245138	XPR-12C LIFT SUPERSTRUCTURE	1	W
2	5250045	XPR-12CL12CL-WB EXTENDED PARIS BOX	1	A
3	5215270	XPR-12CS-LWB XPR-12FD-LWB TRIPLE	4	C
4	5210268	TELESCOPING ARM	2	C
5	5203709	POST EXTENSION WELDMENT	2	C
6	5203187	WARNING LABEL	1	-
7	5205181	2 POSTS GALVANNEZAL	2	C
8	5205404	MAX GALVANNEZAL	1	-
9	5205404	MAX GALVANNEZAL	1	-
10	5205465	MANUFACTURER LABEL	1	-
11	5205660	MAX GALVANNEZAL	1	-
12	5205740	PRODUCT DATA LABEL	1	-
13	5205950	2015 SERIAL TAG-A-5205950	1	-

1645 LEMONWOOD DR.
 BENDPAK, INC.
 SANTA PAULA, CA 93060

TITLE: XPR-12CL-LWB-192
 PRODUCTION LIFT VER E
 SIZE DWG. NO. A 5260565
 REV A

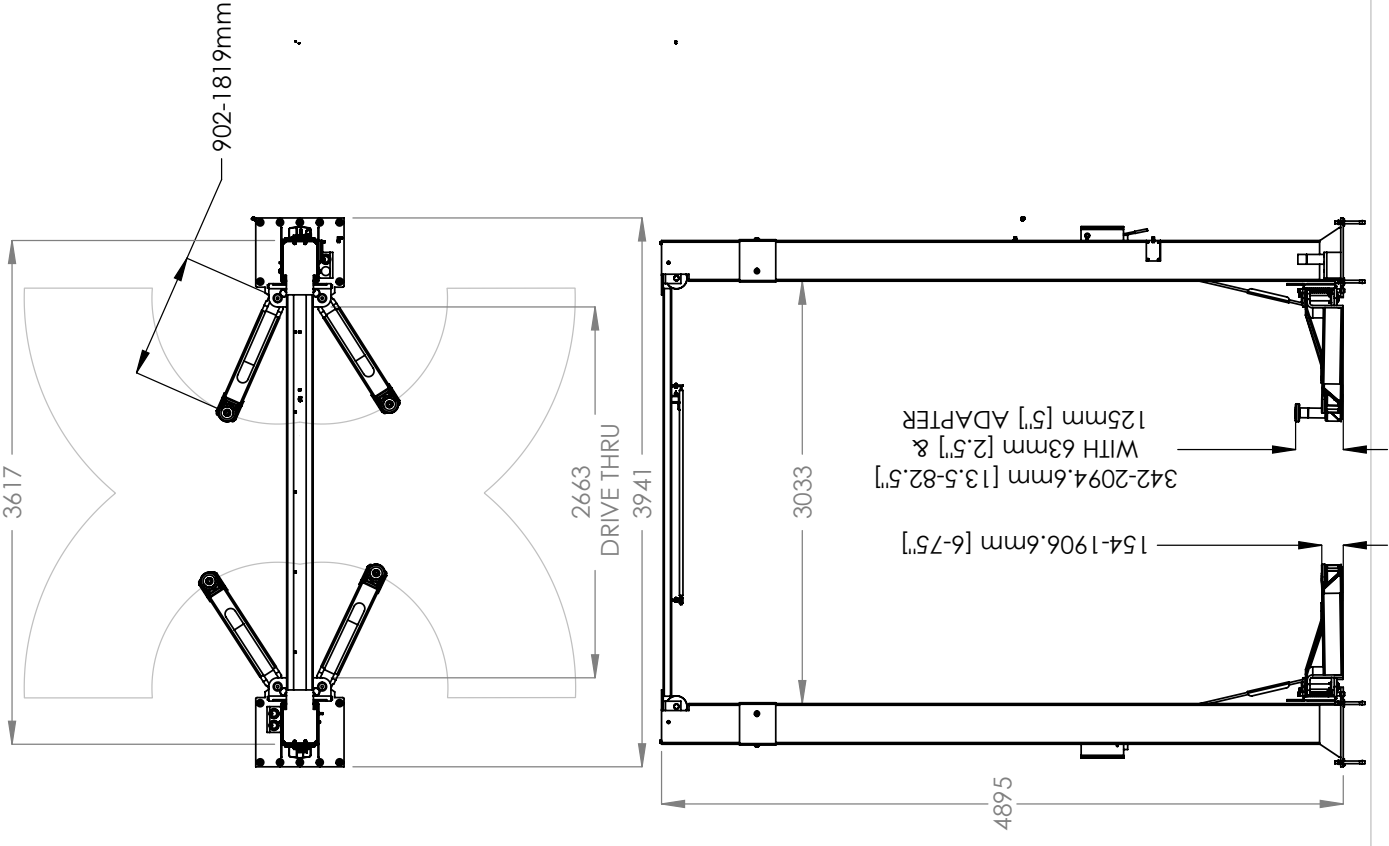

 1645 LEMONWOOD DR. SANTA PAULA, CA 93060	
TITLE:	XPR-12CL-LWB-192 PRODUCTION LIFT VER E
SIZE / DWG. NO.	A / 5260565
REV	A
SCALE:	1:50
SHEET 2 OF 2	

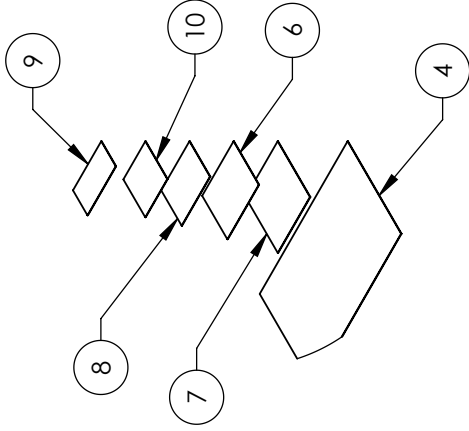
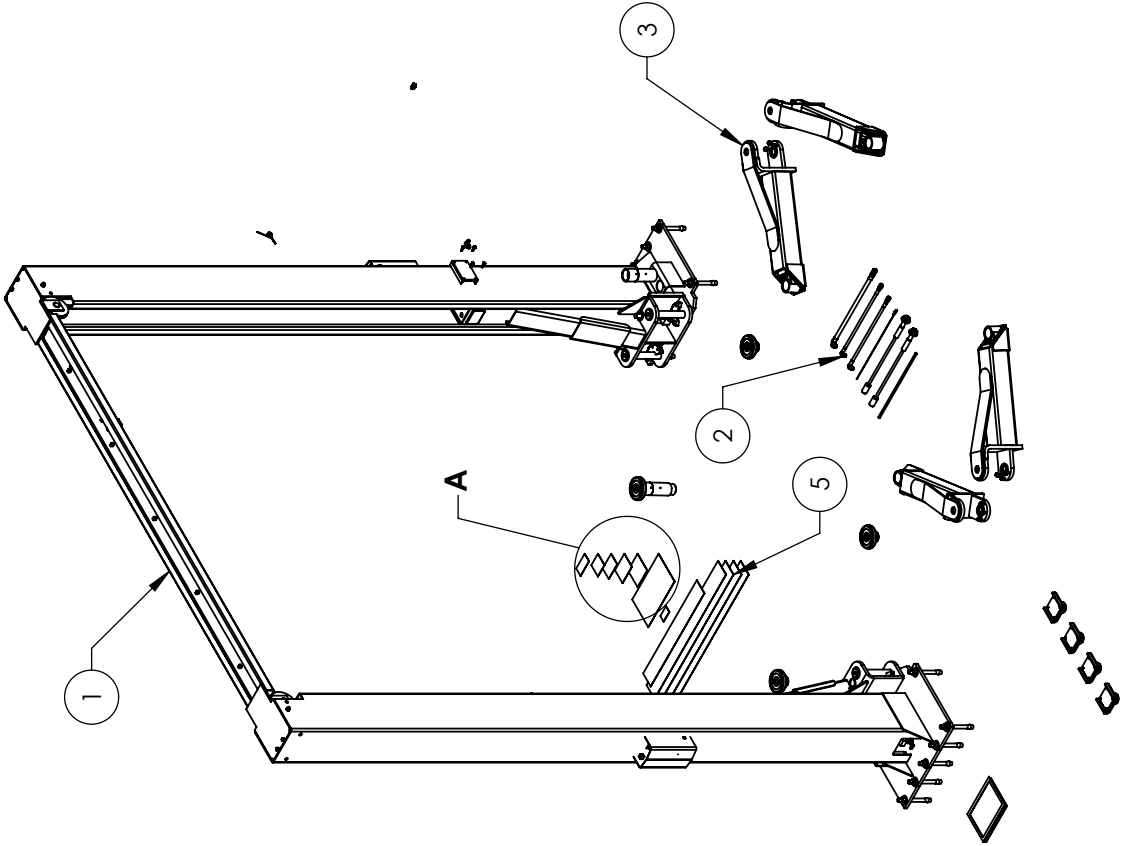

DETAIL A
SCALE 1 : 12

ITEM NO	PART NUMBER	DESCRIPTION	QTY	REV
1	5245138	XPR-12C LIFT SUPERSTRUCTURE	1	W
2	5250041	XPR-12CL/12CL-LWB PARTS BOX	1	A
3	5215283	XPR-12CSL/FDL TRIPLE TELESCOPING ARM ASSEMBLY	4	C
4	5905109	WARNING ALI/WL 101	1	-
5	5905131	2 POST DECAL KIT LESS ALI	1	C
6	5905404	MAX CAP DANGER 12K	1	-
7	5905465	MANUFACTURER LABEL	1	-
8	5905660	MAX CAP NR1L DANGER 12K	1	-
9	5905940	PRODUCT DATA LABEL	1	-
10	5905950	2015 SERIAL TAG-A-5905950	1	-

DO NOT SCALE DRAWING NAME DATE



TITLE: XPR-12CL PRODUCTION LIFT VER E

SIZE	DWG. NO.	REV	SHEET 1 OF 2
A	5260567	A	
SCALE: 1:40			

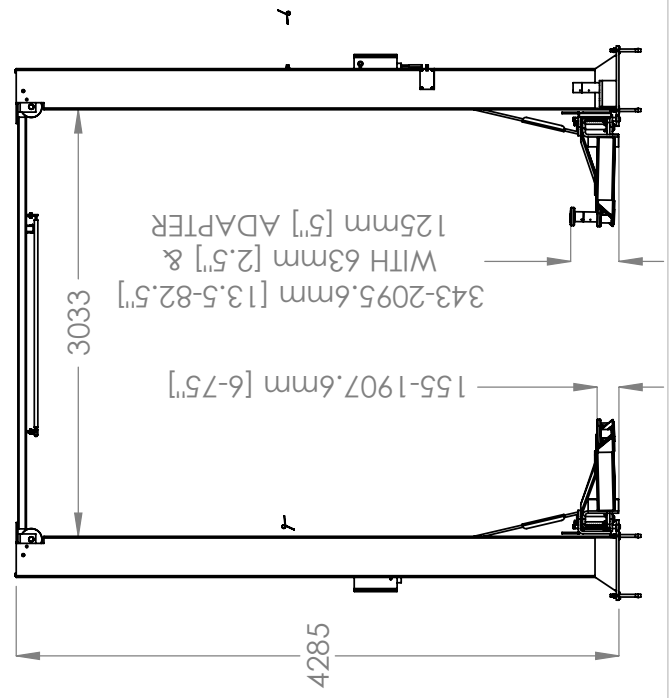
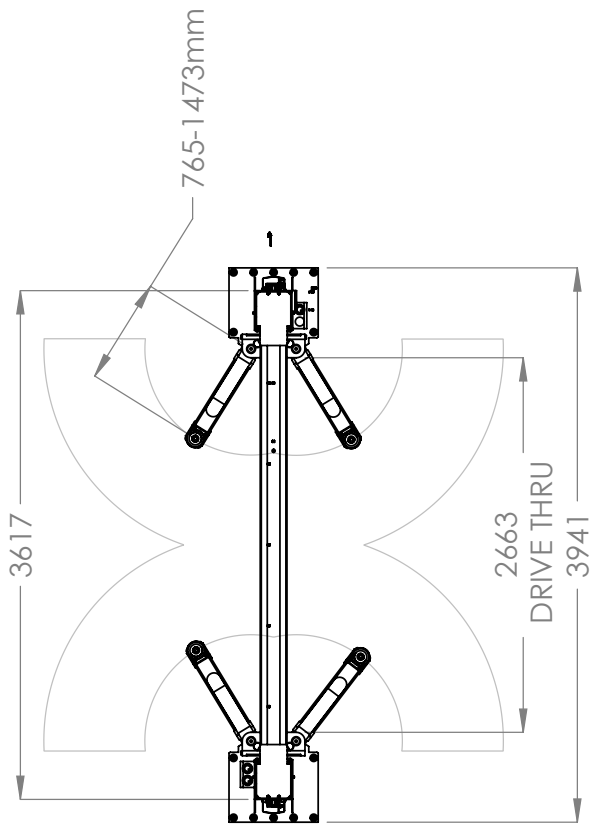

BendPak 1645 LEMONWOOD DR.
SANTA PAULA, CA 93060

TITLE: XPR-12CL PRODUCTION
LIFT VER E

SIZE	DWG. NO.	REV
A	5260567	A

SCALE: 1:50 SHEET 2 OF 2

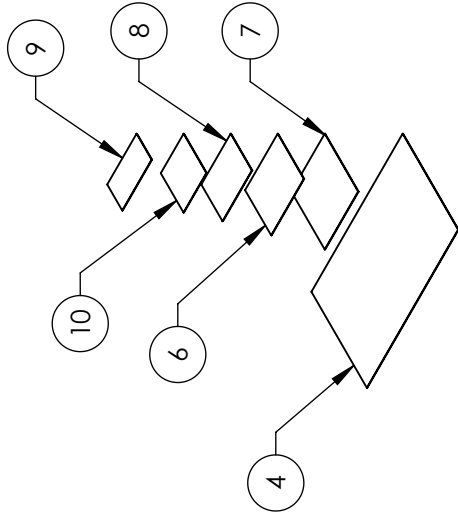
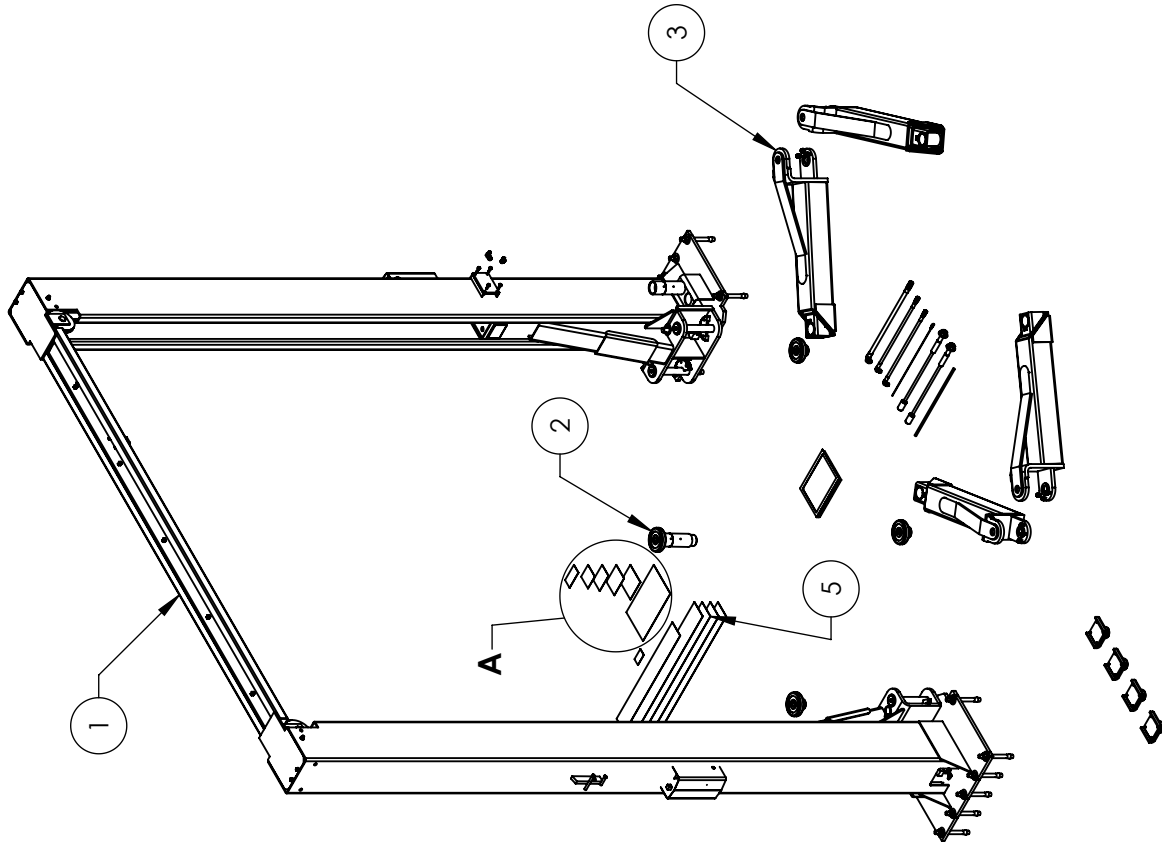

ITEM NO	PART NUMBER	DESCRIPTION	QTY	REV
1	5245138	XPR-12C LIFT SUPERSTRUCTURE	1	W
2	5250041	XPR-12CL/12CL-LWB PARTS BOX	1	A
3	5215270	XPR-12CS-LWB; XPR-12FD-LWB TRIPLE TELESCOPING ARM	4	C
4	5905109	WARNING ALU/WL 101	1	---
5	5905131	2 POST DECAL KIT, LESS ALI	1	C
6	5905404	MAX CAP DANGER 12K	1	---
7	5905465	MANUFACTURER LABEL	1	---
8	5905660	MAX CAP NR1L DANGER 12K	1	---
9	5905940	PRODUCT DATA LABEL	1	---
10	5905950	2015_SERIAL_TAG-A-5905950	1	---

BendPak
 1645 LEMONWOOD DR.
 SANTA PAULA, CA 93060

TITLE: XPR-12CL-LWB
 PRODUCTION LIFT VER E

SIZE DWG. NO. **A** 5260569 REV **A**

SCALE: 1:40 SHEET 1 OF 2

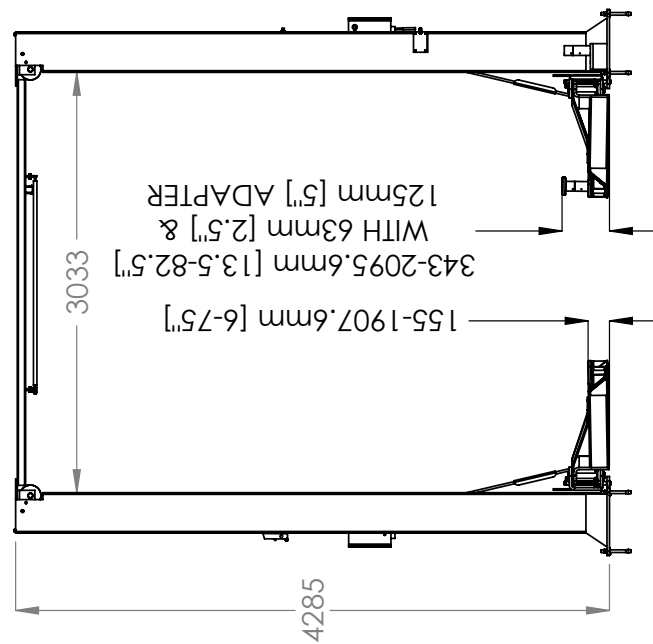
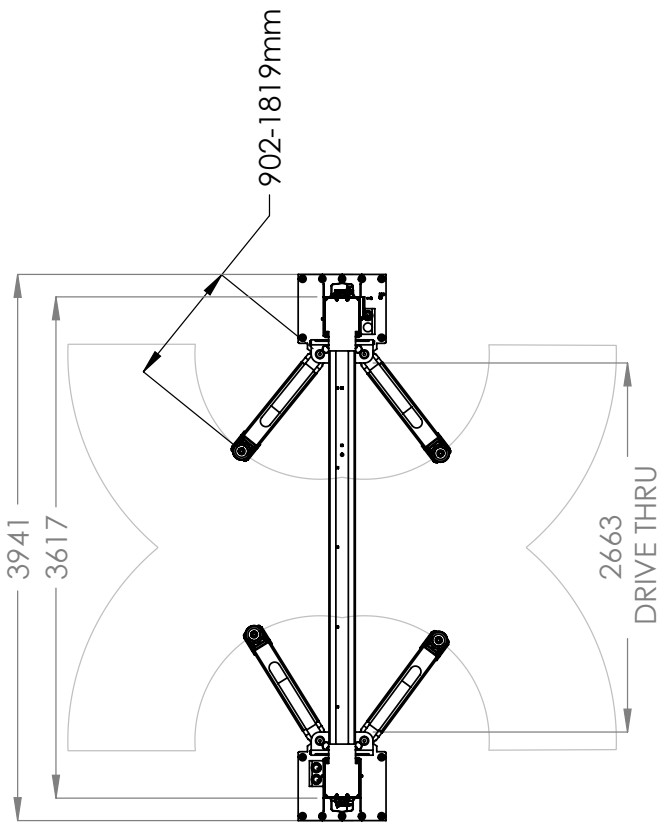

BendPak
 1645 LEMONWOOD DR.
 SANTA PAULA, CA 93060

TITLE:	XPR-12CL-LWB PRODUCTION LIFT VER E	
SIZE DWG. NO.	5260569	REV
A		A
SCALE:	1:50	SHEET 2 OF 2

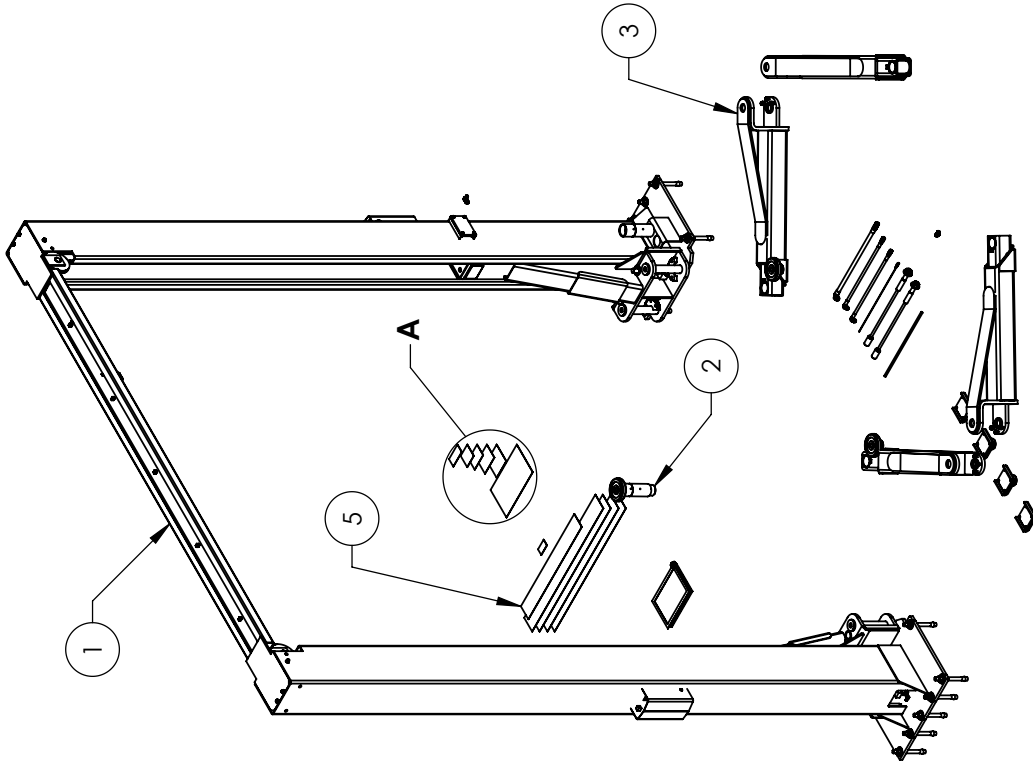

DETAIL A
SCALE 1 : 12

ITEM NO	PART NUMBER	DESCRIPTION	QTY	REV
1	5245139	XPR-15/18CL LIFT SUPERSTRUCTURE	1	W
2	5250043	XPR-15CL PARTS BOX	1	A
3	5215273	XPR-15CL/18CL ARM ASSEMBLY	4	C
4	5905109	WARNING ALI/AWL T01	1	--
5	5905131	2 POST DECAL KIT, LESS ALI	1	C
6	5905405	MAX CAP DANGER 15K	1	--
7	5905465	MANUFACTURER LABEL	1	--
8	5905670	MAX CAP NR TL DANGER 15K	1	--
9	5905940	PRODUCT DATA LABEL	1	--
10	5905950	2015_SERIAL_TAG-A-5905950	1	--



TITLE: XPR-15CL PRODUCTION
LIFT VER E

SIZE DWG. NO. A 5260571
REV A

BendPak 1645 LEMONWOOD DR.
SANTA PAULA, CA 93060

TITLE: XPR-15CL PRODUCTION
LIFT VER E

SIZE DWG. NO. 5260571 REV A

SCALE: 1:50 SHEET 2 OF 2

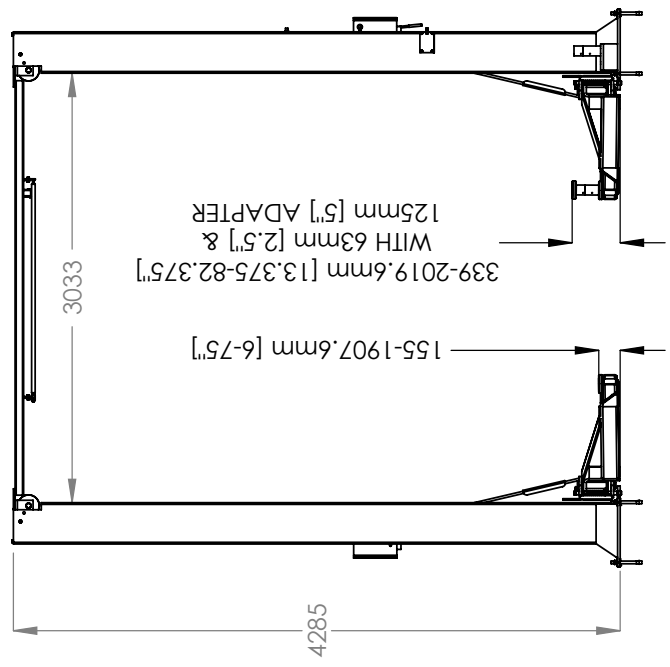
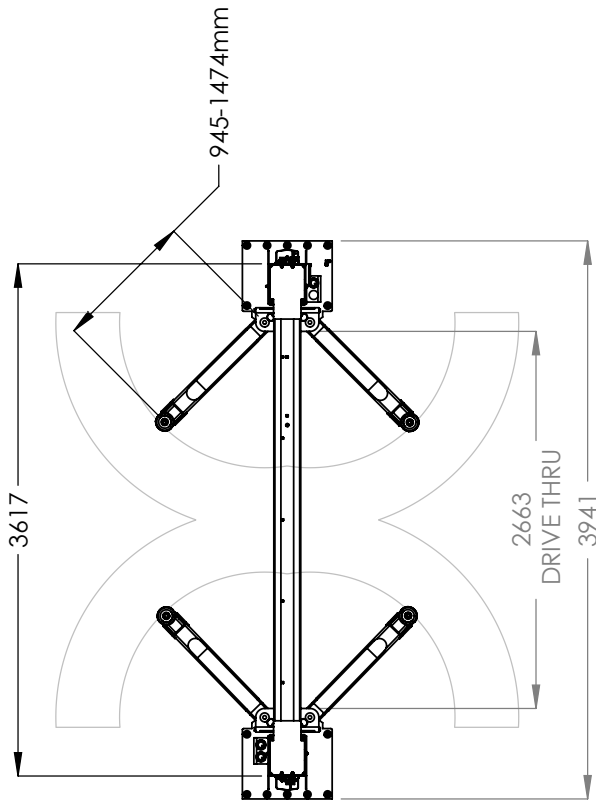

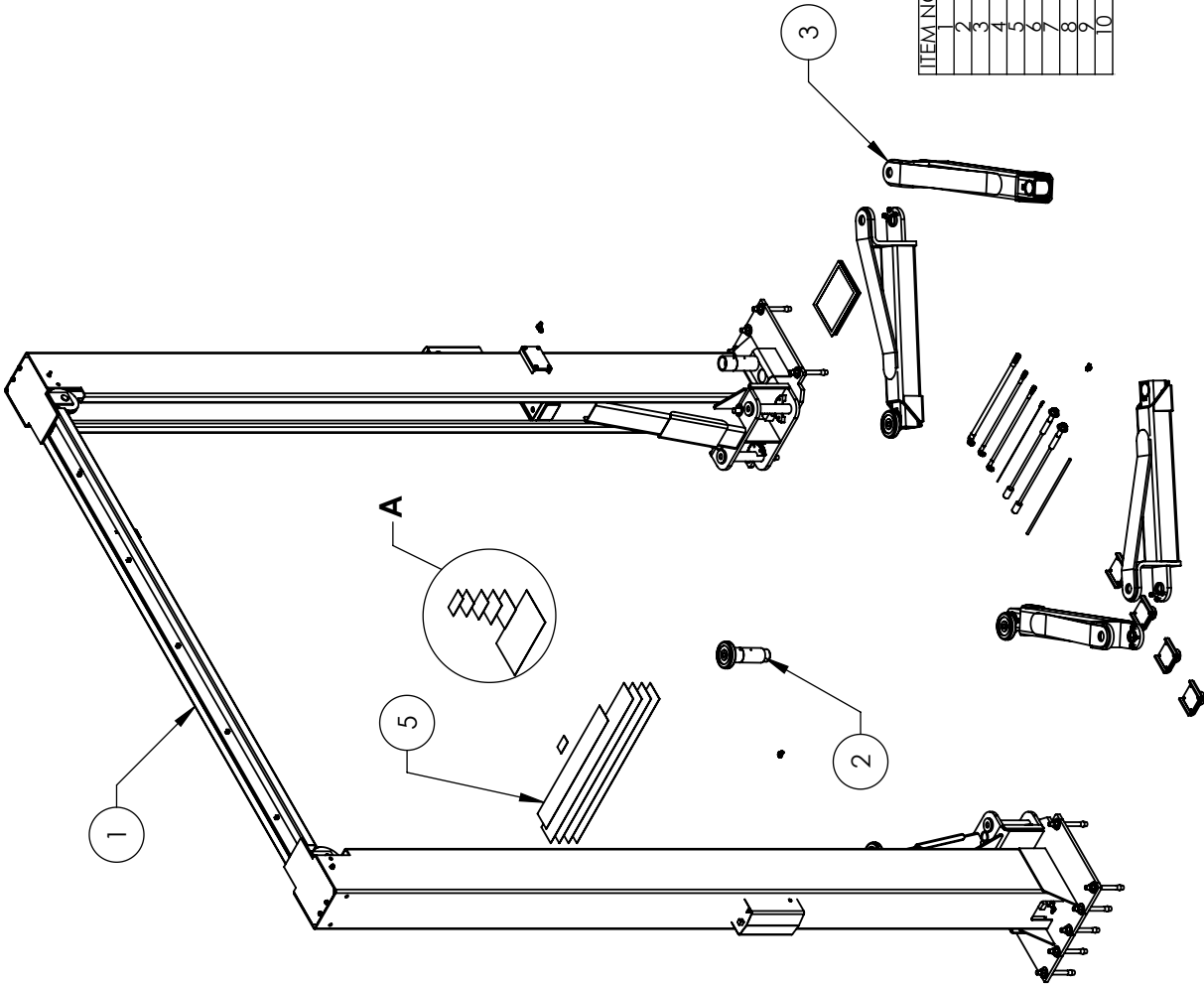

DETAIL A
SCALE 1 : 12

ITEM NO	PART NUMBER	DESCRIPTION	QTY	REV
1	57245139	XPR-15/18CL LIFT SUPERSTRUCTURE	1	W
2	5750044	XPR-18CL PAPER ROY	1	A
3	5750044	XPR-18CL PAPER ROY	1	A
4	5215773	XPR-15CL/18CL ARM ASSEMBLY	4	C
5	5205109	WARNING ALU/W/101	1	C
6	5205131	2 POST DECAL KIT-LESS ALI	1	C
7	5205405	MAX CAP DANGER 15K	1	C
8	5205465	MANUFACTURER LABEL	1	C
9	5205670	MAX CAP NR/DANGER 15K	1	C
10	5205940	PRODUCT DATA LABEL	1	C
	5205950	2015 SERIAL TAG-A-5205950	1	C

BendPak
1645 LEMONWOOD DR.
SANTA PAULA, CA 93060

PR-18CL PRODUCTION
LIFT VER E

WG. NO. **5260576**
REV **A**

SS OTHERWISE SPECIFIED.
FINISHING INSTRUCTIONS FOR FINAL PACKAGING
ELECTRIC TO BE APPLIED TO PORTS AFTER PAINTING

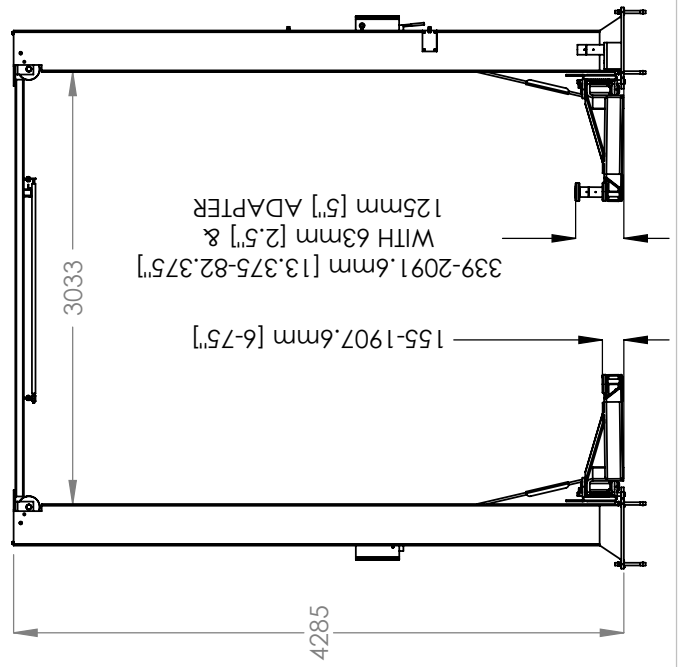
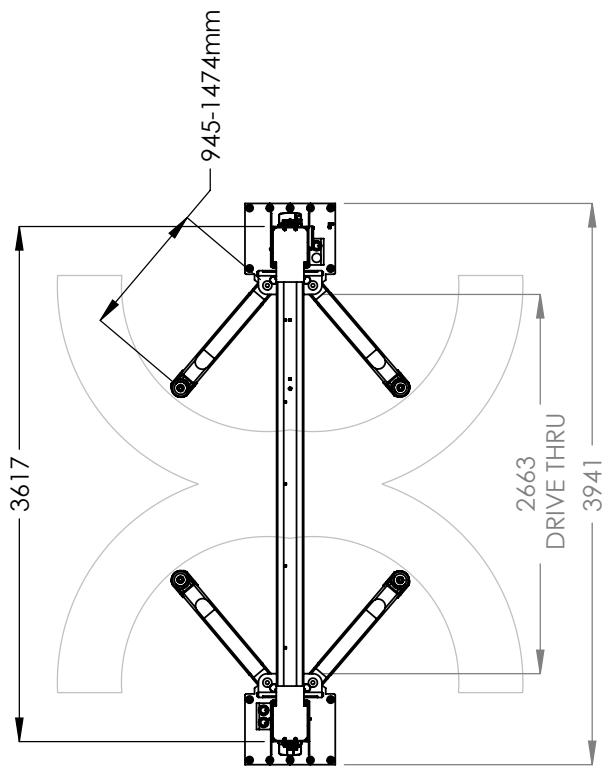

BendPak
1645 LEMONWOOD DR.
SANTA PAULA, CA 93060

TITLE: XPR-18CL PRODUCTION
LIFT VERE

SIZE DWG. NO. 5260576
REV A

SCALE: 1:50 SHEET 2 OF 2



Certificate No: CE-GB-20120209-01-11-5B

Date of Issue: 2016.05.13

Date of Expiry: 2019.01.26



No. 0638

EC Type-Examination Certificate

For the requirements of the Machinery Directive 2006/42/EC

For Annex IV machinery

NAME AND ADDRESS OF THE MANUFACTURER: Bendpak Inc.
1645 E. Lemonwood Drive,
Santa Paula, CA,
United States of America

PRODUCT DESCRIPTION/ TYPE AND MODEL: Range of 12,000(5443kg) 2 post vehicle servicing lift clear floor (top bar) symmetric
XPR-12CL 169H x 155W x 69 Lift in
XPR-12CL-192 192H x 155W x 69 Lift in + Extended
XPR-12CL-LWB 169H x 155W x 69 Lift in
XPR-12CL-LWB-192 192H x 155W x 69 Lift in + Extended
Range of 15,000lb (6804kg) 2 post vehicle servicing lift clear floor (top bar) symmetric
XPR-15CL 169H x 155W x 69 Lift in
XPR-15CL-192 192H x 155W x 69 Lift in + Extended

APPLICABLE STANDARDS: EN1493:2010 Vehicle Lifts
EN 60204-1:2006+A1:2009 Safety of machinery - Electrical equipment of machines - Part1:General requirements

TECHNICAL FILE REF. NO. A COPY IS AVAILABLE FROM: TF-GB-20120209-01-11-5B
CCQS UK Ltd., Level 7, Westgate House, Westgate Road,
London W5 1YY UK

The technical file, accompanying documentation and the equipment which they describe have been found to be in conformity with the requirements of the Machinery Directive 2006/42/EC

The responsible person defined above has responsibility for ensuring that all future serial manufacture of the machinery conforms to the sample submitted for EC type-examination referenced above

Any changes to the design of the machinery certified here must be advised to CCQS UK Ltd. for re-assessment.

A CE marking should not be fixed to the equipment until the requirements of all relevant directives have been met.

Approved by: Owen Bian – UK Office Manager

Date 13.05.2016

CCQS UK Ltd.,
Level 7, Westgate House,
Westgate Road,
London W5 1YY UK
Tel: +44 (0) 20 8991 3488
Email info@ccqs.co.uk

Notified Body
No. 1105
Appointed by
UK Government

If in any doubt about the integrity of this certificate,
please verify it on our website at
<http://www.ccqs.co.uk>

Declaration of Conformity

The equipment which accompanies this declaration is in conformity with EU Directive:
2006/42/EC Machinery Directive

Manufacturer

BendPak Inc.
1645 Lemonwood Dr
Santa Paula Ca, 93060
USA

A copy of the Technical file for this equipment is available from:
CCQS UK Ltd., Level 7, Westgate House, Westgate Rd., London W5 1YY UK

Description of Equipment

Two-Column Vehicle Service Lift

XPR-12CL	12K Cap. / Clearfloor / Two-Post Lift	Serial Numbers 5175405-00000 to 99999-99999-99999
XPR-12CL-LWB	12K Cap. / Clearfloor / Two-Post Lift	Serial Numbers 5175406-00000 to 99999-99999-99999
XPR-12CL-192	12K Cap. / Clearfloor / Two-Post Lift	Serial Numbers 5175407-00000 to 99999-99999-99999
XPR-12CL-LWB-192	12K Cap. / Clearfloor / Two-Post Lift	Serial Numbers 5175415-00000 to 99999-99999-99999
XPR-15CL	15 Cap. / Clearfloor / Two-Post Lift	Serial Numbers 5175408-00000 to 99999-99999-99999
XPR-15CL-192	15 Cap. / Clearfloor / Two-Post Lift	Serial Numbers 5175410-00000 to 99999-99999-99999

A sample of this machinery has been presented to Notified Body number 1105.
CCQS UK Ltd., Level 7, Westgate House, Westgate Rd., London W5 1YY UK

Who have issued an EC type-examination certificate number CE-GB-20150427-01-5A dated 2015.12.10.

The equipment in respect of which this declaration is made conforms to the example to which that certificate relates, and that certificate remains valid.

This declaration of conformity is issued under the sole responsibility of the manufacturer.

The following harmonised standards have been used:

EN1493:2010 Vehicle Lifts

Authorised signatory of manufacturer



Signature:

Name of signatory: Jeffrey S. Kritzer

Position in company: Senior Vice President of Marketing and Sales

Place signed: Santa Paula, CA, USA

Date signed: February 17, 2016



TWO-POST LIFTS/FOUR-POST LIFTS WARRANTY

Better Products – Better Service – Better Value

Duration: From the date of purchase by original Purchaser or 60-24-12 months from the date of shipment by BendPak or whichever comes first.

- ✓ **Five Years (60-Months) Warranty** on the lift structure
- ✓ **Two Years (24-Months) Warranty** on the hydraulic cylinder(s) and power unit
- ✓ **One Year (12-Months) Warranty** on operating components
- ✓ **One Year (12-Months) Labor Warranty** on site or at factory
- ✓ **One Year (12-Months) Free-Shipping*** on ground-freight charges related to warranty performance

Limited Warranty

1. Who gives this warranty (Warrantor): BendPak Inc., 1645 Lemonwood Dr., Santa Paula, CA 93060
2. Who receives this warranty (Purchaser): The original Purchaser (other than for purpose of resale)
3. What products are covered by this warranty: Any BendPak Two-Post or Four-Post Vehicle Service Lift**
4. What is covered under this warranty: manufacturer defects due to material and/or workmanship with the exceptions noted below.
5. What is not covered under this warranty:
 - a. Any failure that results from Purchaser’s abuse, neglect or failure to operate, maintain or service product in accordance with instructions provided in the owner’s manual(s) supplied
 - b. Any damage caused by overloading lift beyond rated capacity
 - c. Items or service normally required to maintain the product, i.e. lubricants, oil, etc.
 - d. Items considered general wear parts such as rubber pads, lifting cables, etc. unless wear or failure is a direct result of manufacturer defect due to material and/or workmanship
 - e. Any component damaged in shipment or any failure caused by installing or operating lift under conditions not in accordance with installation and operation guidelines or damaged by contact with tools or surroundings
 - f. Motor or pump failure caused by rain, excessive humidity, corrosive environments or other contaminants
 - g. Rusted components due to improper maintenance or corrosive environments
 - h. Cosmetic defects that do not interfere with product functionality
 - i. Damage due to incorrect voltage or improper wiring
 - j. Any incidental, indirect, or consequential loss, damage, or expense that may result from any defect, failure, or malfunction of BendPak Inc. product
 - k. All electrical components (excluding power unit) are guaranteed for one year against defects in workmanship and/or materials when the lift is installed and used according to specifications.
6. Responsibilities of Warrantor under this warranty: Repair or replace, at Warrantor’s option, component which is defective, has malfunctioned and/or failed to conform within duration of the warranty period. BendPak Inc. will pay reasonable labor costs for the first 12 months only
7. Responsibilities of Purchaser under this warranty:
 - a. Provide dated proof of purchase and maintenance records
 - b. In some cases, components may be required to be shipped to the nearest BendPak Authorized Service Center. Freight costs, after 12-months, must be borne by the Purchaser.
 - c. Use reasonable care in the operation and maintenance of the products as described in the owner’s manual(s).
8. When Warrantor will perform repair or replacement under this warranty: Repair or replacement will be scheduled and serviced according to the normal work flow at the servicing location, and depending on the availability of replacement parts.

*Free-shipping applies to direct shipping points within the 48 continental United States. Rural area shipping surcharge may apply for remote addresses. **For all BendPak brand Two-Post or Four-Post Vehicle Service Lifts (excluding specialty lifts, high rise, commercial parking, material handling, or models for particular purpose) manufactured on or following 1/1/2011.

Limitation of Liability

BendPak/Ranger shall have no obligation pursuant to this Warranty with respect to products which in our sole judgment have been altered damaged, misused, abused, badly worn, lost or improperly maintained. This Warranty is null and void if the customer or any other person other than an authorized representative of BendPak/Ranger has made any attempt to service or modify the tool prior to its return to BendPak/Ranger under this Warranty. In no event will either party be liable for any damage caused by the other party's failure to fulfill its responsibilities under these terms and conditions. In no event will either party be liable for any lost profits, lost savings, incidental damage, or other economic consequential damages BendPak/Ranger products are provided and sold as is without any express or implied warranties including warranties of merchantability or fitness for particular purpose. No warranties, expressed or implied, will apply after this period. BendPak may modify these terms and conditions at any time by either providing the customer with written notice or posting such revised terms on www.bendpak.com. Such revised terms shall be effective thirty days from the date of such written notice or posting.



1645 Lemonwood Dr. ● Santa Paula, CA. 93060, USA
Toll Free: 1(800) 253-2363

FOR TECHNICAL SUPPORT
1-(800) 253-2363 Ext. 196
TO ORDER PARTS
1-(800) 253-2363 Ext. 191