



IMPORTANT SAFETY INSTRUCTIONS SAVE THESE INSTRUCTIONS

PLEASE READ THE ENTIRE CONTENTS OF THIS MANUAL PRIOR TO INSTALLATION AND OPERATION. BY PROCEEDING WITH LIFT INSTALLATION AND OPERATION YOU AGREE THAT YOU FULLY UNDERSTAND AND COMPREHEND THE FULL CONTENTS OF THIS MANUAL. FORWARD THIS MANUAL TO ALL OPERATORS. FAILURE TO OPERATE THIS EQUIPMENT AS DIRECTED MAY CAUSE INJURY OR DEATH.

MAN REV A 06-13-2013
P/N 5900720

INSTALLATION AND OPERATION MANUAL

**9,000 POUND CAPACITY
SURFACE MOUNTED
TWO-POST LIFTS**

MODELS:

XPR-12FD

VER A

XPR-12FD-LWB

VER A

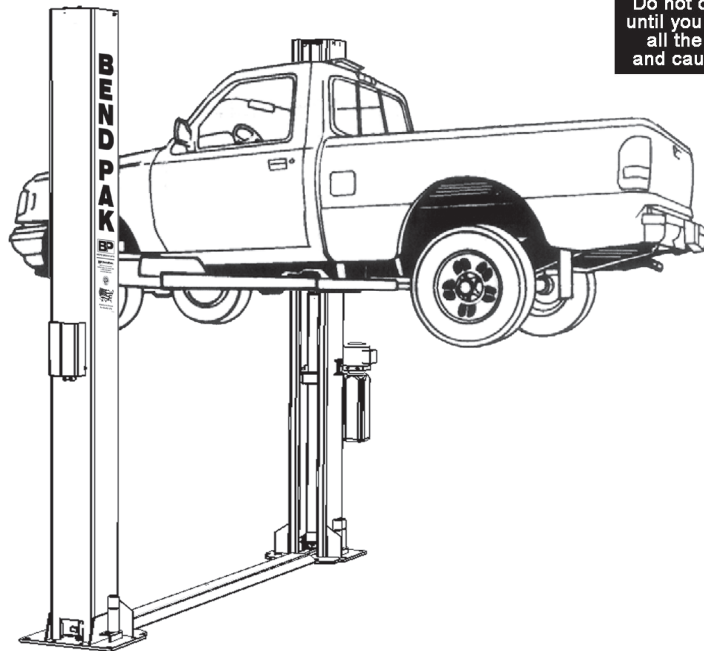

RECEIVING

The shipment should be thoroughly inspected as soon as it is received. The signed Bill of Lading is acknowledgement by the shipping carrier as receipt of this product as listed in your invoice as being in a good condition of shipment. If any of these goods listed on this Bill of Lading are missing or damaged, do not accept goods until the shipping carrier makes a notation on the freight bill of the missing or damaged goods. Do this for your own protection.

BE SAFE

Your new lift was designed and built with safety in mind. However, your overall safety can be increased with proper training and thoughtful operation on the part of the operator. DO NOT operate or repair this equipment without reading this manual and the important safety instructions shown inside. Keep this operation manual near the lift at all times. Make sure that ALL USERS read and understand this manual.

1645 Lemonwood Dr.
Santa Paula, CA. 93060, USA
Toll Free 1-800-253-2363
Tel: 1-805-933-9970
Fax: 1-805-933-9160
www.bendpak.com



12,000 POUND CAPACITY SURFACE MOUNTED TWO-POST LIFTS

This instruction manual has been prepared especially for you. Your new lift is the product of over 40 years of continuous research, testing and development; it is the most technically advanced lift on the market today.

READ THIS ENTIRE MANUAL BEFORE INSTALLATION & OPERATION BEGINS.

RECORD HERE THE LIFT AND POWER UNIT INFORMATION WHICH IS LOCATED ON THE SERIAL NUMBER DATA PLATES ON THE LIFT AND ON THE POWER UNIT

Power Unit Model # _____
 Power Unit Date Of Mfg. _____
 Power Unit Serial # _____
 Max Operating Pressure 2,060 PSI

This information is required when calling for parts or warranty issues.

BP BendPak <small>PROVIDING AUTOMOTIVE SERVICE SOLUTIONS</small>		Santa Paula, CA USA www.bendpak.com
Model Number	Lifting Capacity	Serial Number
Date of Manufacture	Power Unit Number	Volt. / Ph. / Freq. / Amp.
Description	Rolling Jack Max.	Air Pressure Max.
Cable Dia.	Conn. Dia.	Cable Lengths
		A
		C
		B
		D
WARRANTY VOID IF DATA PLATE IS REMOVED. MADE IN CHINA		

PRODUCT WARRANTY

Our comprehensive product warranty means more than a commitment to you; it's also a commitment to the value of your new BendPak lift. For full warranty details and to register your new lift contact your nearest BendPak dealer or visit <http://www.bendpak.com/support/warranty/>

NOTE:

Every effort has been taken to ensure complete and accurate instructions have been included in this manual, however, possible product updates, revisions and or changes may have occurred since this printing. BendPak Ranger reserves the right to change specifications without incurring any obligation for equipment previously or subsequently sold. Not responsible for typographical errors.

IMPORTANT NOTICE

Do not attempt to install this lift if you have never been trained on basic automotive lift installation procedures. Never attempt to lift components without proper lifting tools such as forklift or cranes. Stay clear of any moving parts that can fall and cause injury. These instructions must be followed to ensure proper installation and operation of your lift. Failure to comply with these instructions can result in serious bodily harm and void product warranty. Manufacturer will assume no liability for loss or damage of any kind, expressed or implied resulting from improper installation or use of this product.

PLEASE READ ENTIRE MANUAL PRIOR TO INSTALLATION.

DEFINITIONS OF HAZARD LEVELS

Identify the hazard levels used in this manual with the following definitions and signal words:



DANGER !

Watch for this symbol: It Means: Immediate hazards which will result in severe personal injury or death.



WARNING !

Watch for this symbol: It Means: Hazards or unsafe practices which could result in severe personal injury or death.



CAUTION !

Watch for this symbol: It Means: Hazards or unsafe practices which may result in minor personal injury, product or property damage.

OWNER'S RESPONSIBILITY

To maintain the lift and user safety, the responsibility of the owner is to read and follow these instructions:

- ◆ Follow all installation and operation instructions.
- ◆ Make sure installation conforms to all applicable Local, State, and Federal Codes, Rules, and Regulations; such as State and Federal OSHA Regulations and Electrical Codes.
- ◆ Carefully check the lift for correct initial function.
- ◆ Read and follow the safety instructions. Keep them readily available for machine operators.
- ◆ Make certain all operators are properly trained, know how to safely and correctly operate the unit, and are properly supervised.
- ◆ Allow unit operation only with all parts in place and operating safely.
- ◆ Carefully inspect the unit on a regular basis and perform all maintenance as required.
- ◆ Service and maintain the unit only with authorized or approved replacement parts.
- ◆ Keep all instructions permanently with the unit and all decals on the unit clean and visible.

BEFORE YOU BEGIN

Receiving:

The shipment should be thoroughly inspected as soon as it is received. The signed bill of lading is acknowledgement by the carrier of receipt in good condition of shipment covered by your invoice. If any of the goods called for on this bill of lading are shorted or damaged, do not accept them until the carrier makes a notation on the freight bill of the shorted or damaged goods. Do this for your own protection.

NOTIFY THE CARRIER AT ONCE if any hidden loss or damage is discovered after receipt and request the carrier to make an inspection. If the carrier will not do so, prepare a signed statement to the effect that you have notified the carrier (on a specific date) and that the carrier has failed to comply with your request.

IT IS DIFFICULT TO COLLECT FOR LOSS OR DAMAGE AFTER YOU HAVE GIVEN THE CARRIER A CLEAR RECEIPT. File your claim with the carrier promptly. Support your claim with copies of the bill of lading, freight bill, invoice, and photographs, if available. Our willingness to assist in helping you process your claim does not make BendPak responsible for collection of claims or replacement of lost or damaged materials.

TABLE OF CONTENTS

Contents	Page No.
Warranty / Serial Number Information	2
Definitions of Hazard Levels	3
Owner's Responsibility	3
Before You Begin	3
Installer/Operator Agreement/ Protective Equipment	5
Introduction	6
Safety / Warning Instructions	6
Tools Required	7
Step 1 / Selecting Site	7
Step 2 / Floor Requirements	7
Concrete Specifications	7
Assembly View / Description of Parts	8
Clearances	9
Step 3 / Column Preparation	10
Step 4 / Site Layout / Floor Plan	11
Step 5 / Installing Power Side Column	12
Step 6 / Installing Off Side Column	12
Step 7 / Mounting The Hydraulic Power Unit	13
Step 8 / Installing the Safeties and Safety Cable	13-15
Step 9 / Installing Hydraulic Lines	15-16
Step 10 / Routing the Equalizer Cables	16-17
Step 11 / Installing Floor Plate and Safety Cover	18
Step 12 / Installing the Lift Arms	18-19
Carriage Stop Bolt Installation Warning.	20
Step 13 / Power Unit Connection	21-22
Step 14 / Lift Start Up / Final Adjustments	22
Post Installation Checklist	23
Step 15 / Lubrication.	23
Step 16 / Bleeding the Cylinders	23
Optional Equipment Installation.	24-25
Step 17 / Operation/ Maintenance	26-36
Troubleshooting Guide	37-41
Torque Recommendations	41
Maintenance Records	42
Installation Form	43
Part Number Lists	44-48
Certificate of Compliance	49

**INSTALLER / OPERATOR
PLEASE READ AND FULLY
UNDERSTAND. BY PROCEEDING
YOU AGREE TO THE FOLLOWING.**

- ◆ I have visually inspected the site where the lift is to be installed and verified the concrete to be in good condition and free of cracks or other defects. I understand that installing a lift on cracked or defective concrete could cause lift failure resulting in personal injury or death.
- ◆ I understand that a level floor is required for proper installation and level lifting.
- ◆ I understand that I am responsible if my floor is of questionable slope and that I will be responsible for all charges related to pouring a new level concrete slab if required and any charges.
- ◆ I understand that BendPak lifts are supplied with concrete fasteners meeting the criteria of the American National Standard "Automotive Lifts - Safety Requirements for Construction, Testing, and Validation" ANSI/ALI ALCTV-2006, and that I will be responsible for all charges related to any special, regional, structural, and/or seismic anchoring requirements specified by any other agencies and/or codes such as the Uniform Building Code (UBC) and/or International Building Code (IBC).
- ◆ I will assume full responsibility for the concrete floor and condition thereof, now or later, where the above equipment model is to be installed. Failure to follow Danger, Warning, and Caution instructions may lead to serious personal injury or death to operator or bystander or damage to property.
- ◆ I understand that BendPak lifts are designed to be installed in indoor locations only. Failure to follow installation instructions may lead to serious personal injury or death to operator or bystander or damage to property or lift.

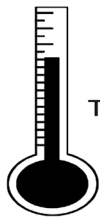

CAUTION

The safe operating temperature range for this product is 41° F. - 104 °F.



THIS SYMBOL POINTS OUT IMPORTANT SAFETY INSTRUCTIONS WHICH IF NOT FOLLOWED COULD ENDANGER THE PERSONAL SAFETY AND/OR PROPERTY OR YOURSELF AND OTHERS AND CAN CAUSE PERSONAL INJURY OR DEATH. READ AND FOLLOW ALL INSTRUCTIONS IN THIS MANUAL BEFORE ATTEMPTING TO OPERATE THIS MACHINE.



Failure to follow Danger, Warning, and Caution instructions may lead to serious personal injury or death to operator or bystander or damage to property.



Please read the entire manual prior to installation. Do not operate this machine until you have read and have understood all of the Danger, Warning and Caution alerts in this manual. For additional copies or further information, contact:

BendPak Inc.

1645 Lemonwood Dr.

Santa Paula, CA. 93060

1-805-933-9970

www.bendpak.com

**INSTALLER / OPERATOR
PROTECTIVE EQUIPMENT**

Personal protective equipment helps makes installation and operation safer, however, it does not take the place of safe operating practices. Always wear durable work clothing during any installation and/or service activity. Shop aprons or shop coats may also be worn, however loose-fitting clothing should be avoided.

Tight-fitting leather gloves are recommended to protect the technician's hands when handling parts. Sturdy leather steel-toe work shoes and oil resistant soles should be used by all service personnel to help prevent injury during typical installation and operation activities.

Eye protection is essential during installation and operation activities. Safety glasses with side shields, goggles, or face shields are acceptable. Back belts provide support during lifting activities and are also helpful in providing worker protection. Consideration should also be given to the use of hearing protection if service activity is performed in an enclosed area, or if noise levels are high.



INTRODUCTION

1. Carefully remove the crating and packing materials. **CAUTION!** Be careful when cutting steel banding material as items may become loose and fall causing personal harm or injury.

2. Check the voltage, phase, and proper amperage requirements for the motor shown on the motor plate. Electrical work should be performed only by a certified electrician.

IMPORTANT SAFETY INSTRUCTIONS

Read these safety instructions entirely. Do not attempt to install this lift if you have never been trained on basic automotive lift installation procedures. Never attempt to lift components without proper lifting tools such as forklift or cranes. Stay clear of any moving parts that may fall and cause injury. When using your garage equipment, basic safety precautions should always be followed, including the following:

1. Read and understand all instructions and all safety warnings before operating lift.
2. Care must be taken as burns can occur from touching hot parts.
3. Do not operate equipment with a damaged cord or if the equipment has been dropped or damaged until it has been examined by a qualified service person.
4. Do not let a cord hang over the edge of the table, bench, or counter or come in contact with hot manifolds or moving fan blades.
5. If an extension cord is necessary, a cord with a current rating equal to or more than that of the equipment should be used. Cords rated for less current than the equipment may overheat. Care should be taken to arrange the cord so that it will not be tripped over or pulled.
6. Always unplug equipment from electrical outlet when not in use. Never use the cord to pull the plug from the outlet. Grasp plug and pull to disconnect.
7. Let equipment cool completely before putting away. Loop cord loosely around equipment when storing.
8. To reduce the risk of fire, do not operate equipment in the vicinity of open containers of flammable liquids (gasoline).
9. Adequate ventilation should be provided when working on operating internal combustion engines.
10. Keep hair, loose clothing, fingers, and all parts of body away from moving parts. Keep feet clear of lift when lowering. Avoid pinch points.
11. **DANGER!** To reduce the risk of electric shock, do not use on wet surfaces or expose to rain. The power unit used on this lift contains high voltage. Disconnect power at the receptacle or at the circuit breaker switch before performing any electrical repairs. Secure plug so that it cannot be accidentally plugged in during service. or mark circuit breaker switch so that it cannot be accidentally switched on during service.
12. Use only as described in this manual. Use only manufacturer's recommended attachments.



13. **ALWAYS WEAR SAFETY GLASSES.** Everyday eye-glasses only have impact resistant lenses, they are not safety glasses.
14. Consider work environment. Keep work area clean. Cluttered work areas invite injuries. Keep areas well lit.
15. Guard against electric shock. This lift must be grounded while in use to protect operator from electric shock. Never connect the green power cord wire to a live terminal. This is for ground only.
16. Only trained operators should operate this lift. All non-trained personnel should be kept away from the work area. Never let non-trained personnel come in contact with, or operate lift.
17. **DO NOT** override self-closing lift controls.
18. Clear area if vehicle is in danger of falling.
19. **ALWAYS** make sure the safeties are engaged before attempting to work on or near a vehicle.
21. **WARNING! RISK OF EXPLOSION.** This equipment has internal arcing or sparking parts which should not be exposed to flammable vapors. This machine should not be located in a recessed area or below floor level.
22. **MAINTAIN WITH CARE.** Keep lift clean for better and safer performance. Follow manual for proper lubrication and maintenance instructions. Keep control handles and/or buttons dry, clean and free from grease and oil.
23. Check for damaged parts. Check for alignment of moving parts, breakage of parts or any condition that may affect operation of lift. Do not use lift if any component is broken or damaged.
24. **NEVER** remove safety related components from the lift. Do not use lift if safety related components are missing or damaged.
23. **STAY ALERT.** Use common sense and watch what you are doing. Remember, **SAFETY FIRST.**



SAVE THESE INSTRUCTIONS

TOOLS REQUIRED

- ◆ Rotary Hammer Drill or Similar
- ◆ 3/4" Masonry Bit
- ◆ Hammer
- ◆ 4 Foot Level
- ◆ Open-End Wrench Set: SAE/Metric
- ◆ Socket And Ratchet Set: SAE/Metric
- ◆ Hex-Key / Allen Wrench Set
- ◆ Large Crescent Wrench
- ◆ Large Pipe Wrench
- ◆ Crow Bar
- ◆ Chalk Line
- ◆ Medium Flat Screwdriver
- ◆ Tape Measure: 25 Foot Minimum
- ◆ Needle Nose Pliers

IMPORTANT NOTICE!

These instructions must be followed to ensure proper installation and operation of your lift. Failure to comply with these instructions can result in serious bodily harm and void product warranty. Manufacturer will assume no liability for loss or damage of any kind, expressed or implied resulting from improper installation or use of this product.

PLEASE READ ENTIRE MANUAL PRIOR TO INSTALLATION !

STEP 1

(Selecting Site)

Before installing your new lift, check the following.

1. **LIFT LOCATION:** Always use architects plans when available. Check layout dimension against floor plan requirements making sure that adequate space if available.
2. **OVERHEAD OBSTRUCTIONS:** The area where the lift will be located should be free of overhead obstructions such as heaters, building supports, electrical lines etc.
3. **DEFECTIVE FLOOR:** Visually inspect the site where the lift is to be installed and check for cracked or defective concrete.



4. **OPERATING TEMPERATURE.** Operate lift only between temperatures of 41° -104° F.
5. Lift is designed for **INDOOR INSTALLATION ONLY.** Outdoor use permitted only if covered and dry. Always follow warnings illustrated on equipment labels.

STEP 2

(Floor Requirements)



This lift must be installed on a solid level concrete floor with no more than 3-degrees of slope. Failure to do so could cause personal injury or death.

A level floor is suggested for proper use and installation and level lifting. If a floor is of questionable slope, consider a survey of the site and/or the possibility of pouring a new level concrete slab.



- ◆ **DO NOT** install or use this lift on any asphalt surface or any surface other than concrete.
- ◆ **DO NOT** install or use this lift on expansion seams or on cracked or defective concrete.
- ◆ **DO NOT** install or use this lift on a second / elevated floor without first consulting building architect.

CONCRETE SPECIFICATIONS

LIFT MODEL	CONCRETE REQUIREMENTS
XPR-9D	4" Min. Thickness / 3,000 PSI
XPR-9DT	4" Min. Thickness / 3,000 PSI



DANGER!

All models **MUST** be installed on 3000 PSI concrete only conforming to the minimum requirements shown above. New concrete must be adequately cured by at least 28 days minimum.

IMPORTANT NOTE:

BendPak lifts are supplied with installation instructions and concrete fasteners meeting the criteria as prescribed by the American National Standard "Automotive Lifts - Safety Requirements for Construction, Testing, and Validation" ANSI/ALI ALCTV-2011. Lift buyers are responsible for any special regional structural and/or seismic anchoring requirements specified by any other agencies and/or codes such as the Uniform Building Code (UBC) and/or International Building Code (IBC).



When removing the lift from shipping angles, pay close attention as the posts can slide and can cause injury. Prior to removing the bolts make sure the posts are held securely by a fork lift or some other heavy lifting device.

PARTS INVENTORY

Be sure to take a complete inventory of parts prior to beginning installation.

Description	Qty
Floorplate	1
Arm Assemblies	4
Rear Arm Assembly	2
Frame Contact Pads	4
Frame Cradle Pads	4
Off Side Column with Carriage Assembly	1
Power Side Column with Carriage Assembly	1
Hydraulic Cylinder	2
Parts Box (Packing List Enclosed)	1
Parts Bag (Packaged in Part Box)	1
Hydraulic Power Unit	1

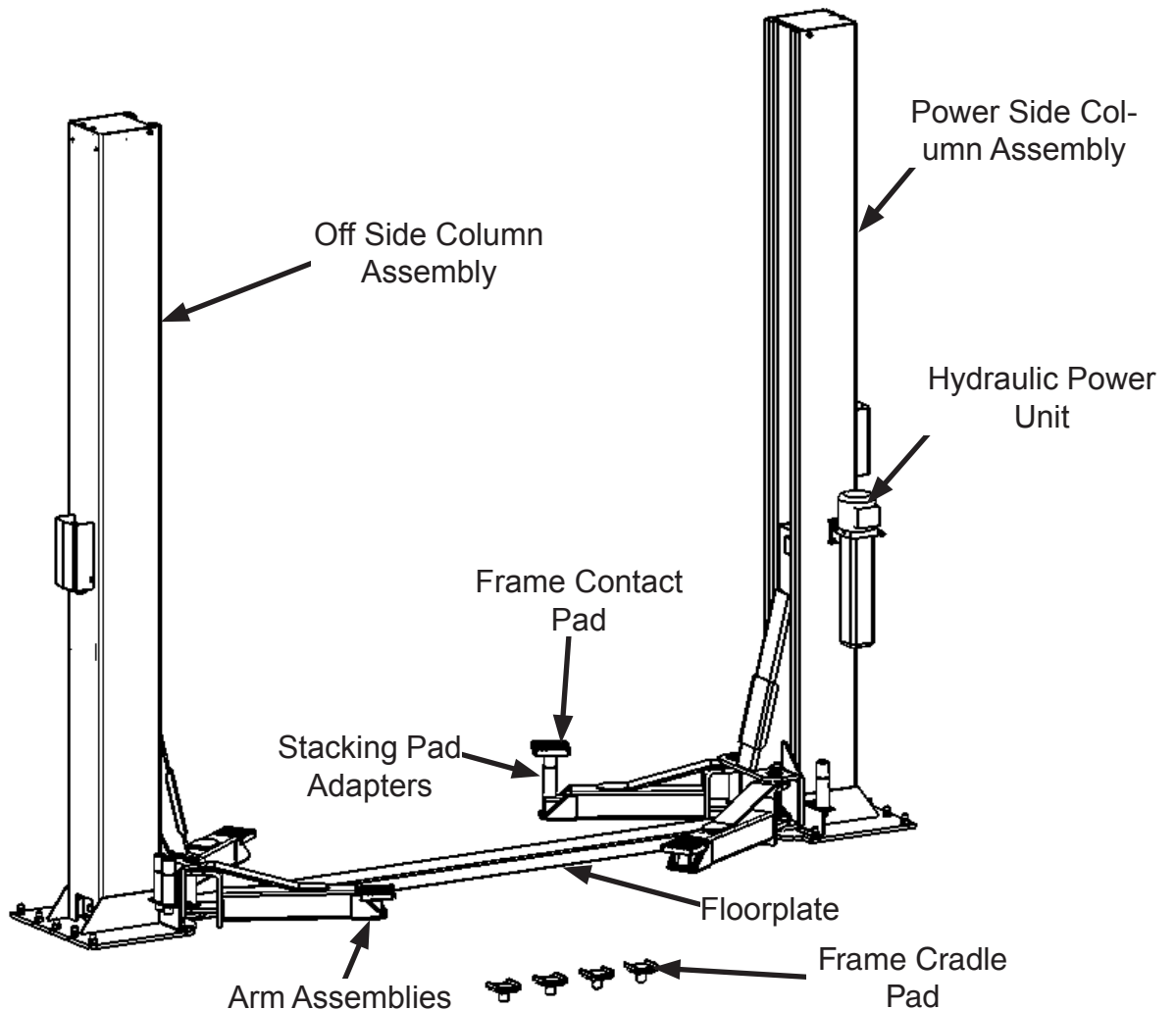

CLEARANCES XPR-12FD

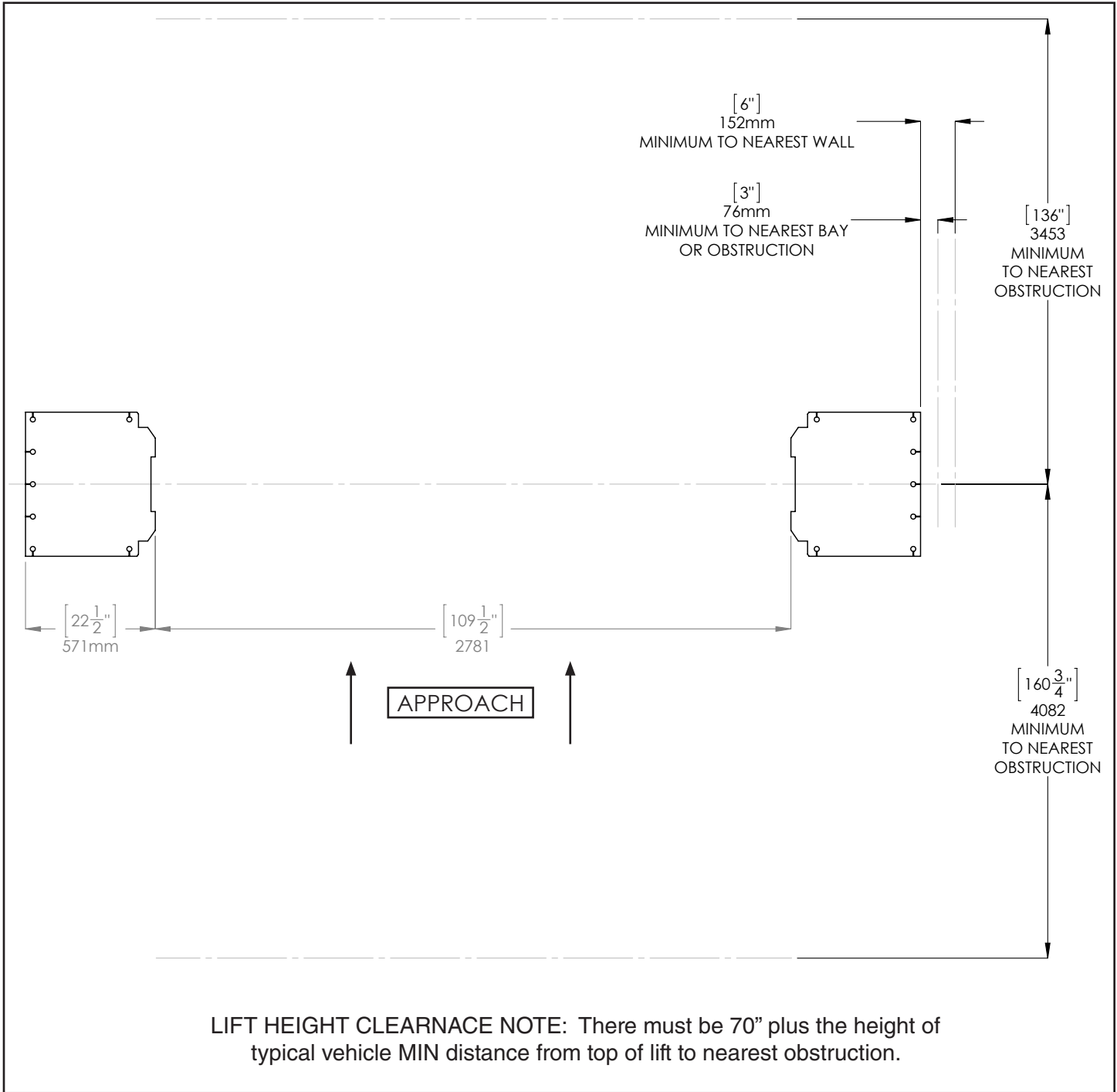

STEP 3
(Column Preparation)
 COMPLETE THE FOLLOWING
 PRIOR TO RAISING THE COLUMNS

1. Prior to raising posts, slide each carriage upwards to expose the cylinder port in the base of the hydraulic cylinder and to aid in sheave removal and equalizer cable routing. (See Fig 3.1)

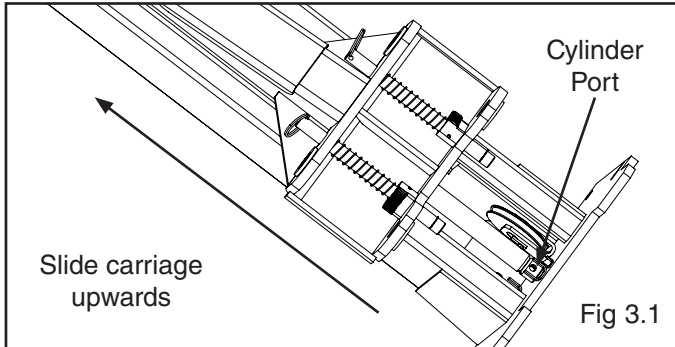

2. Install a 1/4" NPT straight fitting into each cylinder port using teflon tape then temporarily remove the cable sheaves located at the inside bottom of each Column by first removing the hex head bolts, and then by removing the sheave pin. (See Fig 3.2)

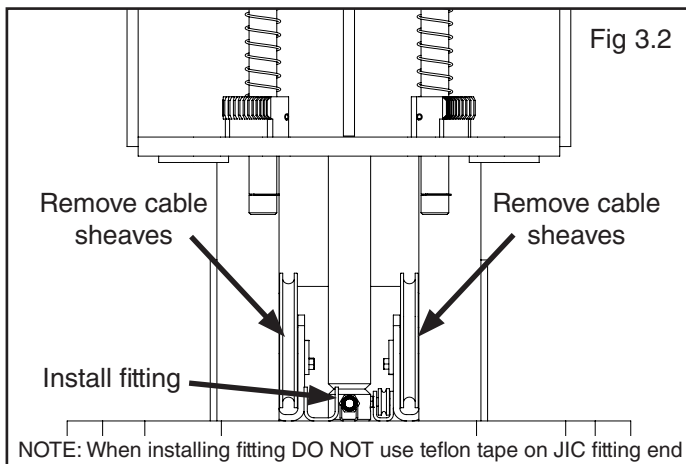

3. Route button end of the cable upwards through the bottom of the carriage and wrap the cable around the cable sheave and reinstall sheave by reversing the sheave removal procedure. Leave excess cable tied together in a coil to carriage until further steps are required. (See Fig 3.3 & 3.4)

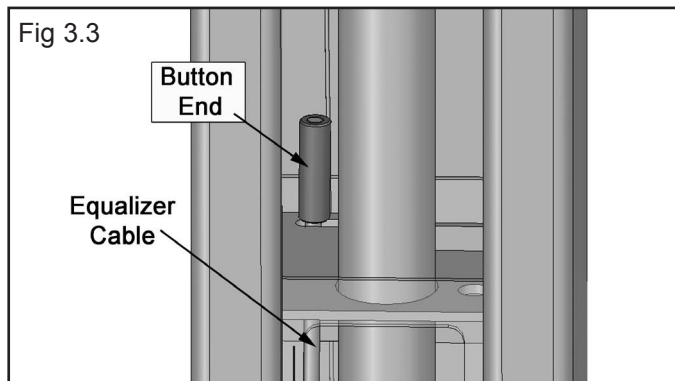

NOTE:
 REFER TO STEP 10 FOR CABLE ROUTING DETAILS.
 ROUTE BUTTON END OF CABLES PRIOR TO
 RAISING UP THE POSTS.

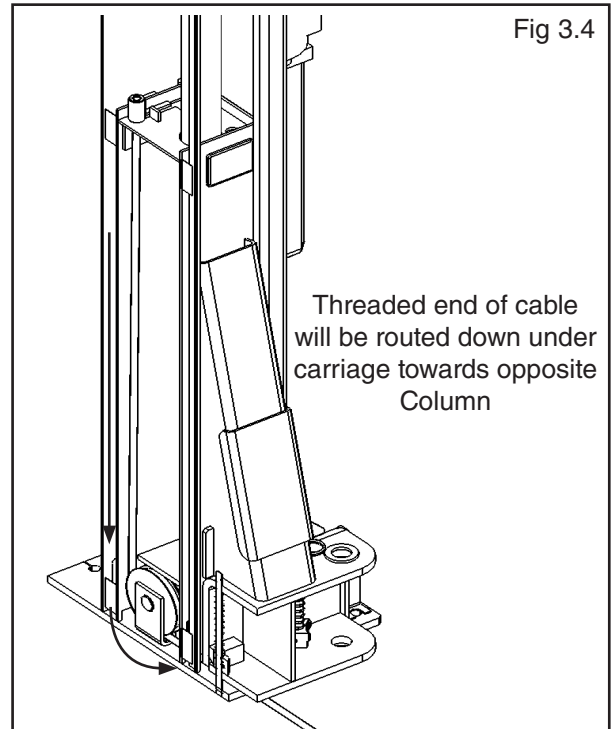

NOTE: Portions of Carriage and Column cut away for clarity

4. To install optional sheave covers, place sheave cover on sheave bracket so that the bracket return faces towards the sheave and align pin holes and bolt holes. The cutout in the bracket for the cable must be facing towards the base plate. Insert pin through sheave cover, sheave bracket, and sheave. Align pin bolt hole with sheave cover bolt hole and sheave bracket bolt hole and insert M6 hex head bolt and tighten. (See Fig 3.5)

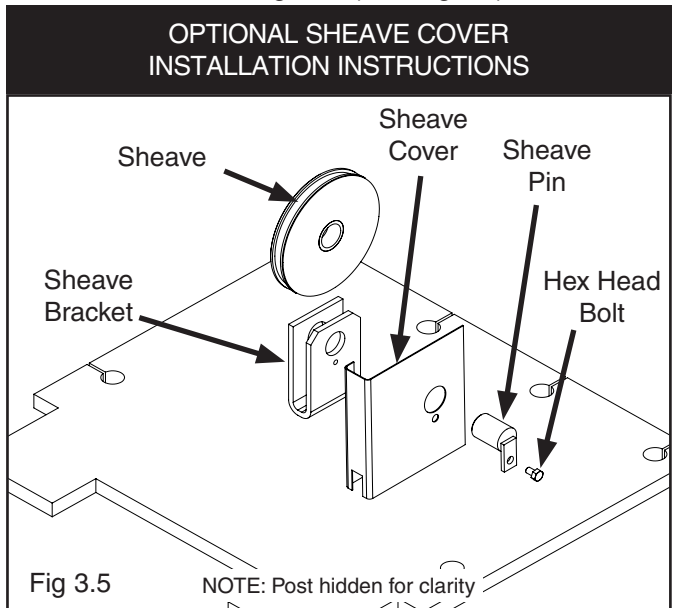

SITE LAYOUT / FLOOR PLAN

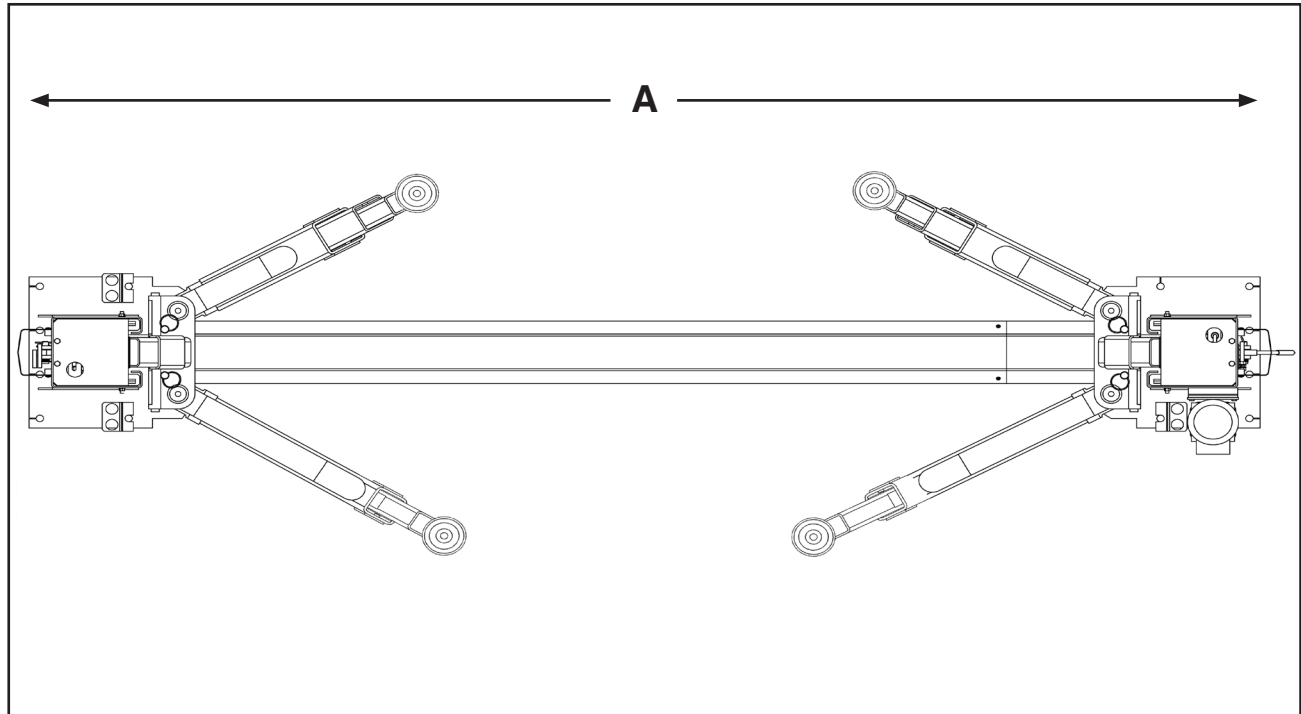

Model	A	Capacity
XPR-12FD	3342 mm / 132"	12,000 LBS

STEP 4 (Site Layout)

1. Determine which side of the lift will be the approach side.
2. Now determine where the power unit will be located. The POWER SIDE column has the power unit mounting bracket attached to the side.
3. Use the chart on this page to determine which lift width layout you would like to use.
4. Once a location is determined, use a carpenters chalk

line to layout a grid for the Column locations. Keep all dimensions square within 1/8" (3mm) or malfunctioning of the lift can occur.

5. After the Column locations are properly marked, use chalk or crayon to make an outline of the posts on the floor at each Column location using the Column base plates as a template. (See Fig 4.1)

6. **CHECK ALL DIMENSIONS TWICE** and make sure that the layout is perfectly square.

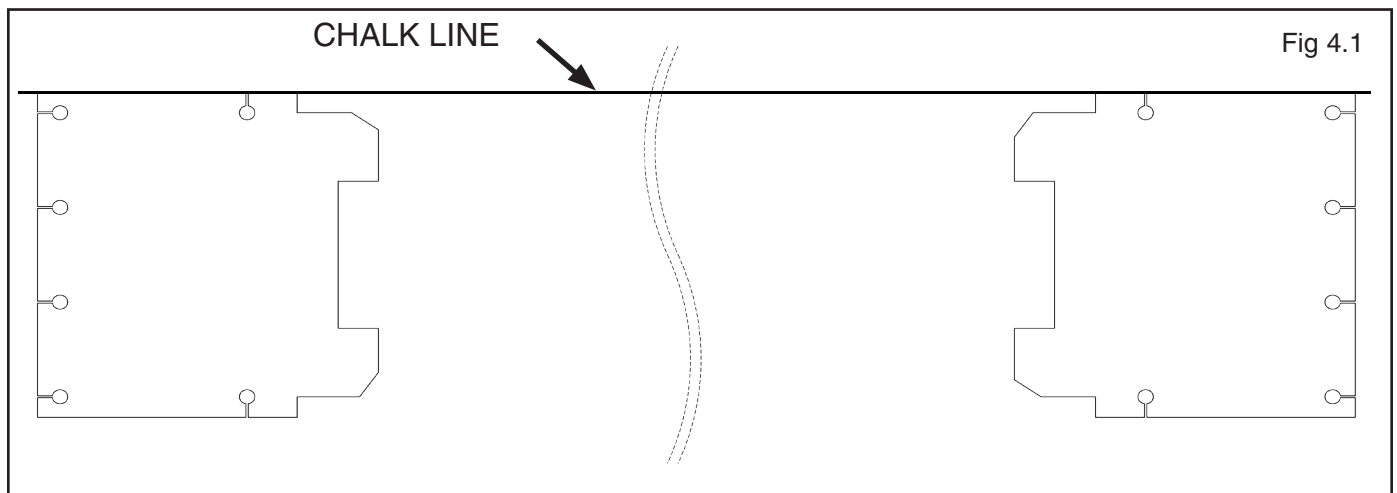

STEP 5 (Installing the POWER SIDE Column)

1. Before proceeding, double the check measurements and make certain that the base plate of each Column is aligned with the chalk line.

NOTE:

BENDPAK LIFTS ARE SUPPLIED WITH INSTALLATION INSTRUCTIONS AND CONCRETE FASTENERS MEETING THE CRITERIA AS PRESCRIBED BY THE AMERICAN NATIONAL STANDARD "AUTOMOTIVE LIFTS - SAFETY REQUIREMENTS FOR CONSTRUCTION, TESTING, AND VALIDATION" ANSI/ALI ALCTV-2011. LIFT BUYERS ARE RESPONSIBLE FOR ANY SPECIAL REGIONAL STRUCTURAL AND/OR SEISMIC ANCHORING REQUIREMENTS SPECIFIED BY ANY OTHER AGENCIES AND/OR CODES SUCH AS THE UNIFORM BUILDING CODE (UBC) AND/OR INTERNATIONAL BUILDING CODE (IBC).

2. Using the base plate on the POWER SIDE Column as a guide, drill each anchor hole in the concrete approximately 6" deep for 12K using a rotary hammer drill and 3/4" concrete drill-bit. To ensure full holding power, do not ream the hole or allow the drill to wobble. (See Fig. 5.1)

3. After drilling, remove dust thoroughly from each hole making certain that the posts remain aligned with the chalk line.

4. Assemble the washers and nuts on the anchors then tap into each hole with a hammer until the washer rests against the base plate. If shimming is required be sure that enough threads are left exposed. (See Fig. 5.2)

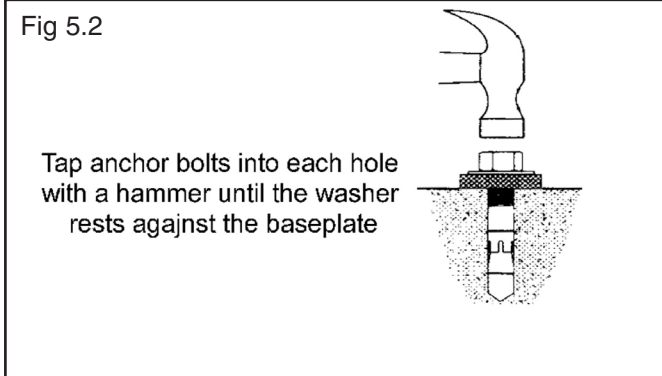
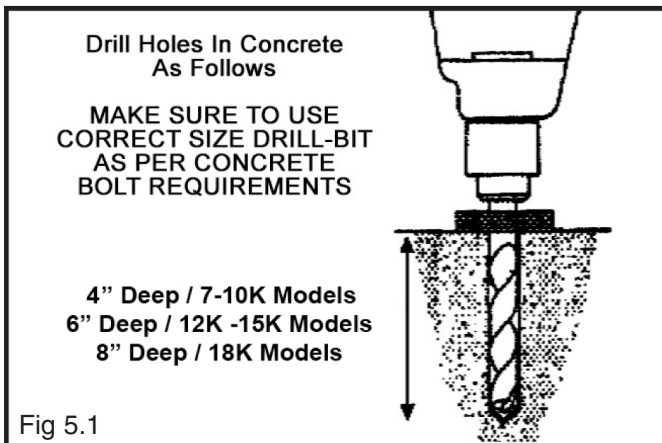

5. If shimming is required, insert the shims as necessary under the base plate so that when the anchor bolts are tightened, the posts will be plumb. (See Fig. 5.3)

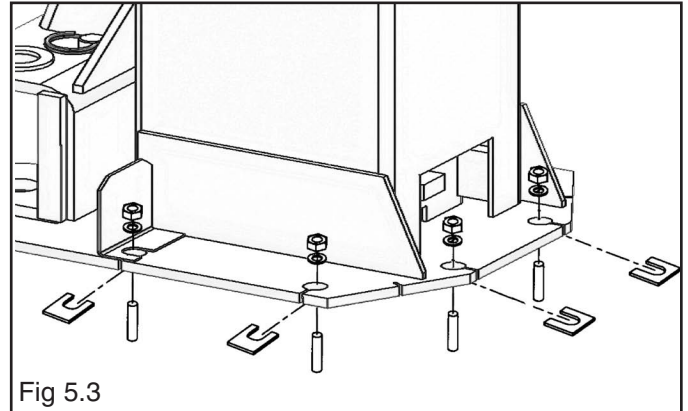

6. If installing the optional foot guards, place foot guards on left and right side as shown. (See Fig 5.4)

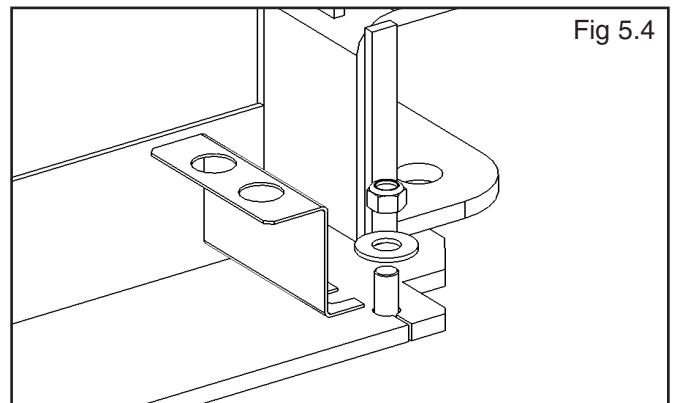

7. With the foot guards, shims and anchor bolts in place, tighten by securing the nut to the base then turning 3-5 full turns clockwise. **DO NOT** use an impact wrench for this procedure. (See Fig. 5.5)

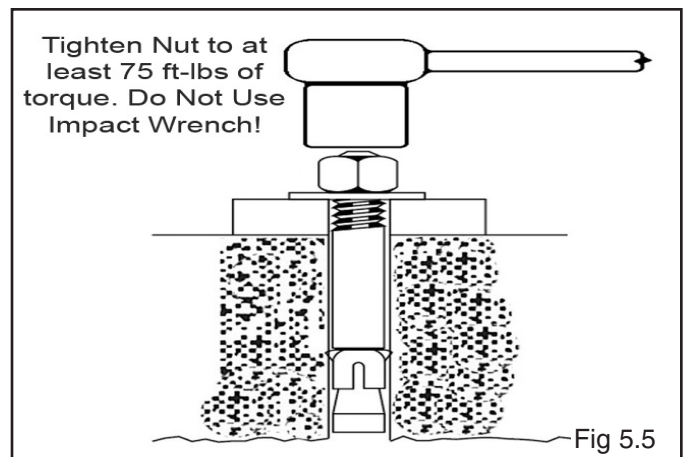

STEP 6 (Installing the OFF SIDE Column)

1. Position the OFF SIDE Column at the designated chalk locations and secure Column to floor following the same procedures as outlined in STEP 5; Paragraphs 1-6.

STEP 7 (Mounting the Hydraulic Power Unit)

1. Attach the power unit to the POWER SIDE Column. Install the vibration dampener between the power unit and the power unit mounting plate on the Power Side Column, using four M8 hex head bolts and nuts supplied. (See Fig 7.1)

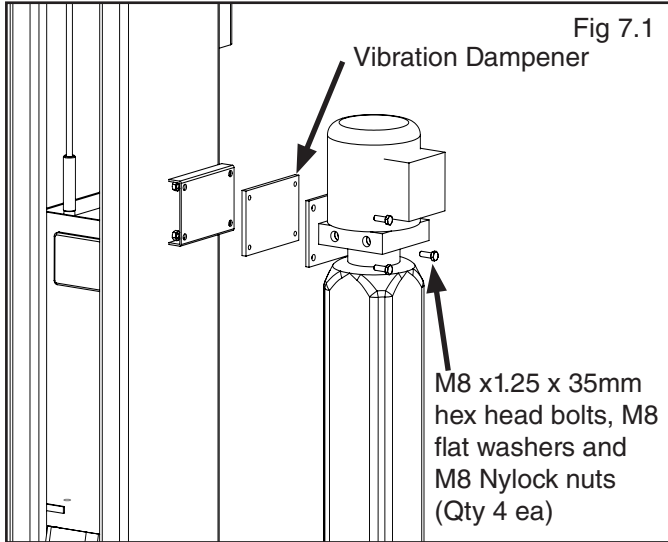

2. Fill the reservoir with 10 WT. HYDRAULIC OIL OR DEXRON TYPE III ATF, approximately four gallons. Make sure the funnel used to fill the Power Unit is clean.

Do not connect power unit hydraulic hose assembly at this time.

3. The standard power unit for your lift is 220 volt, 60HZ, single phase. All wiring must be performed by a certified electrician only. SEE WIRING INSTRUCTIONS AFFIXED TO MOTOR FOR PROPER WIRING INSTRUCTIONS.



DANGER !
ALL WIRING MUST BE PERFORMED
BY A LICENSED ELECTRICIAN.



DANGER!
DO NOT PERFORM ANY MAINTENANCE OR INSTALLATION OF ANY COMPONENTS WITHOUT FIRST ENSURING THAT ELECTRICAL POWER HAS BEEN DISCONNECTED AT THE SOURCE OR PANEL AND CANNOT BE RE-ENERGIZED UNTIL ALL MAINTENANCE AND/OR INSTALLATION PROCEDURES ARE COMPLETED.



WARNING!
DO NOT RUN POWER UNIT WITHOUT OIL. DAMAGE TO POWER UNIT PUMP CAN OCCUR. THE POWER UNIT MUST BE KEPT DRY. DAMAGE TO POWER UNIT CAUSED BY WATER OR OTHER LIQUIDS SUCH AS DETERGENTS, ACID ETC., IS NOT COVERED UNDER WARRANTY.

OPERATE LIFT ONLY BETWEEN TEMPERATURES OF 41° - 104° F. IMPROPER ELECTRICAL HOOK-UP CAN DAMAGE MOTOR AND WILL NOT BE COVERED UNDER WARRANTY. MOTOR CAN NOT RUN ON 50HZ WITHOUT A PHYSICAL CHANGE IN THE MOTOR.

USE A SEPARATE CIRCUIT BREAKER FOR EACH POWER UNIT. PROTECT EACH CIRCUIT WITH TIME DELAY FUSE OR CIRCUIT BREAKER.

FOR 208-230 VOLT, SINGLE PHASE, USE A 25 AMP FUSE.
FOR 208-230 VOLT, THREE PHASE, USE A 20 AMP FUSE.
FOR 380-440 VOLT, THREE PHASE, USE A 15 AMP FUSE.

STEP 8 (Installing the Safeties and Safety Cable)

1. Install safety weldments on to each respective Column. (See Figs 8.1 - 8.2)

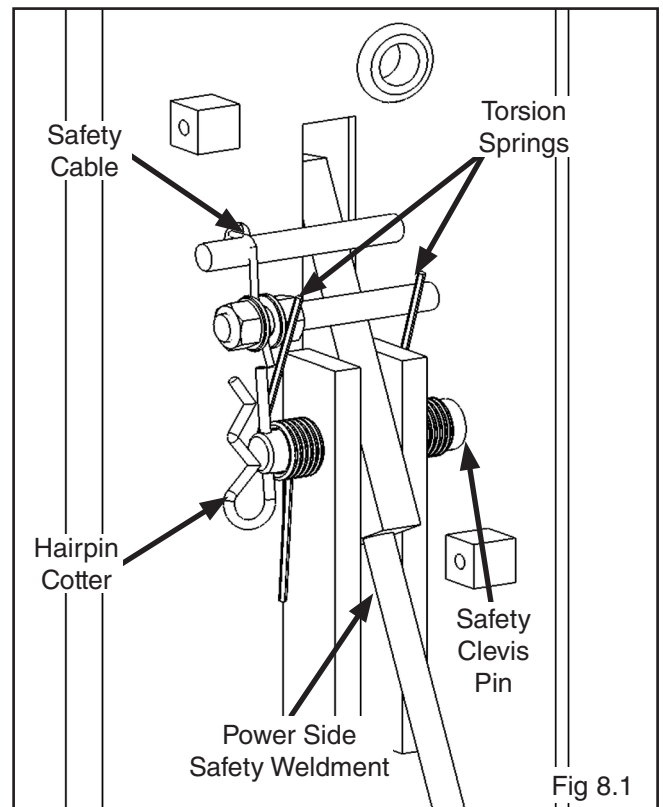

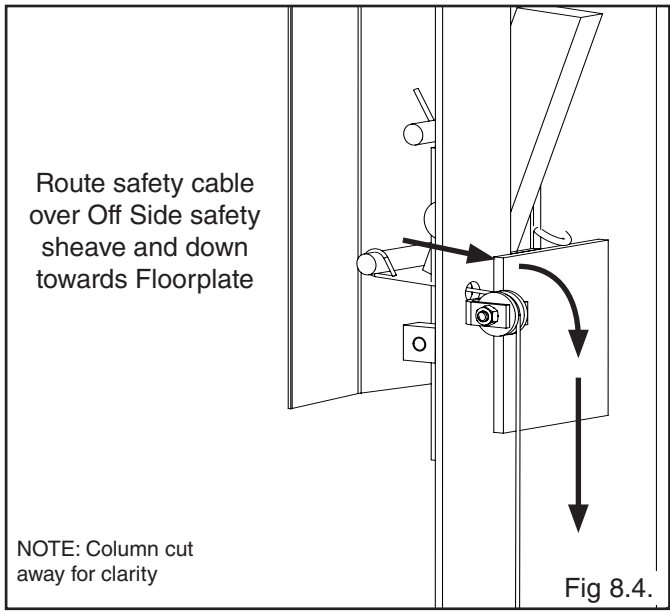
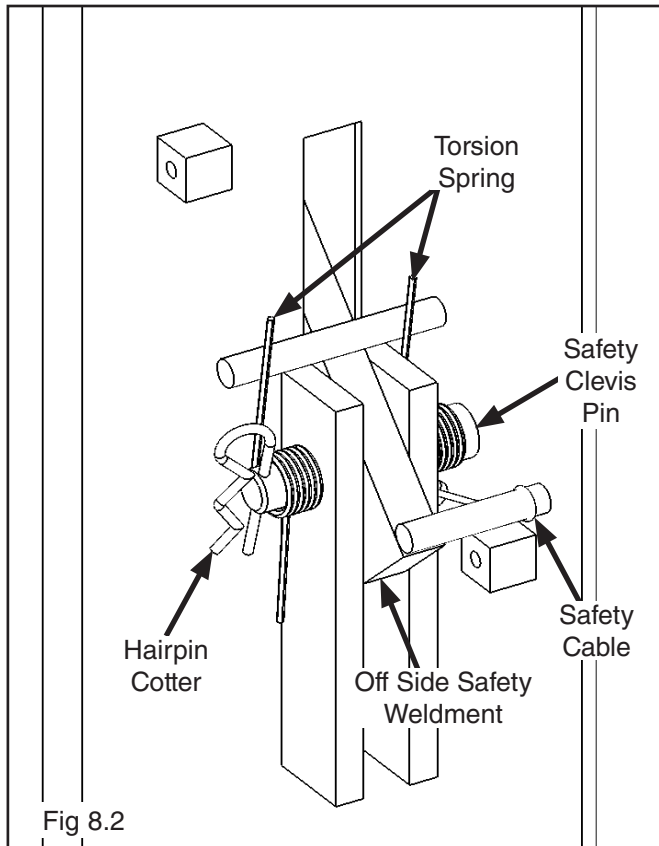

2. From the Off Side Column insert the non-looped end of the safety cable through the hole located to the right of the Off Side safety weldment. (See Fig 8.3)

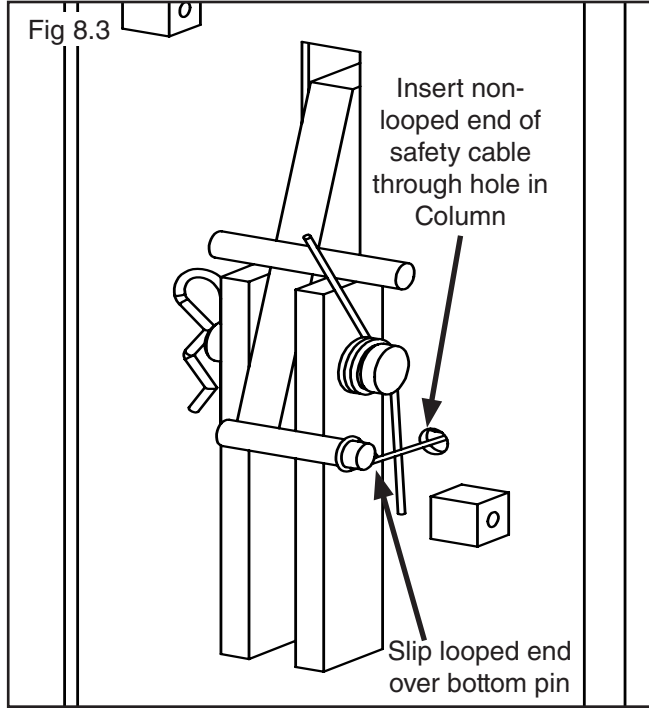
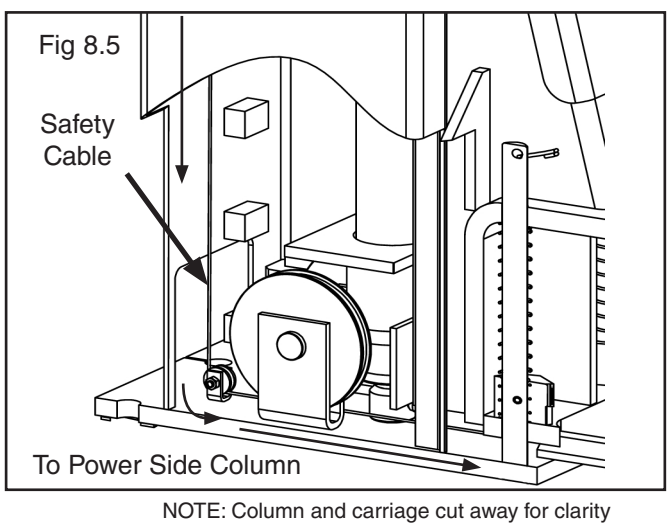

3. Route the cable over the sheave and route it towards the baseplate safety sheave. (See Fig 8.4)

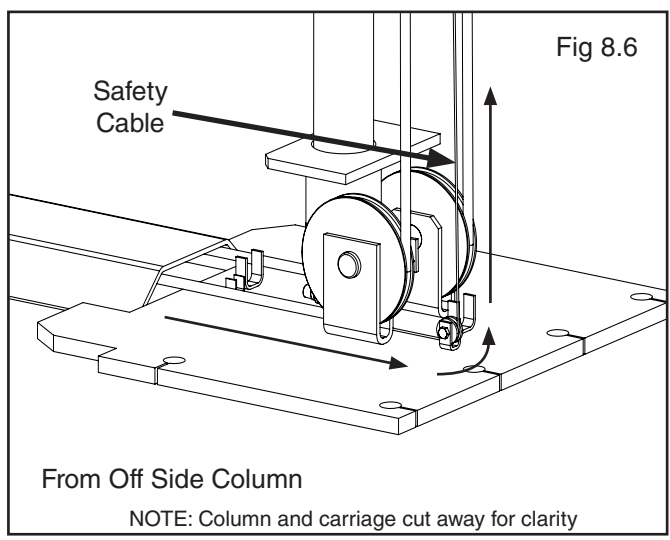

4. Route the cable through the baseplate's safety sheave(s) and across the floor towards the Power Side Column. (See Fig 8.5 - 8.6)

5. Route the cable the same way as on the Power Side going up the Column and over the safety cable sheave.

6. Route the cable over the top pin on the safety handle. Insert the cable end through the hole on the threaded pin. (See Fig 8.7)

7. Pull the slack out the safety cable and keep tension on the cable as nuts are being tightened. Tighten jam nuts on either side of the cable keeping the cable centered to the hole to secure it into place. (See Fig 8.7)

NOTE:
MAKE SURE TO KEEP THE SAFETY CABLE CENTERED WHEN TIGHTENING JAM NUTS ON SAFETY.

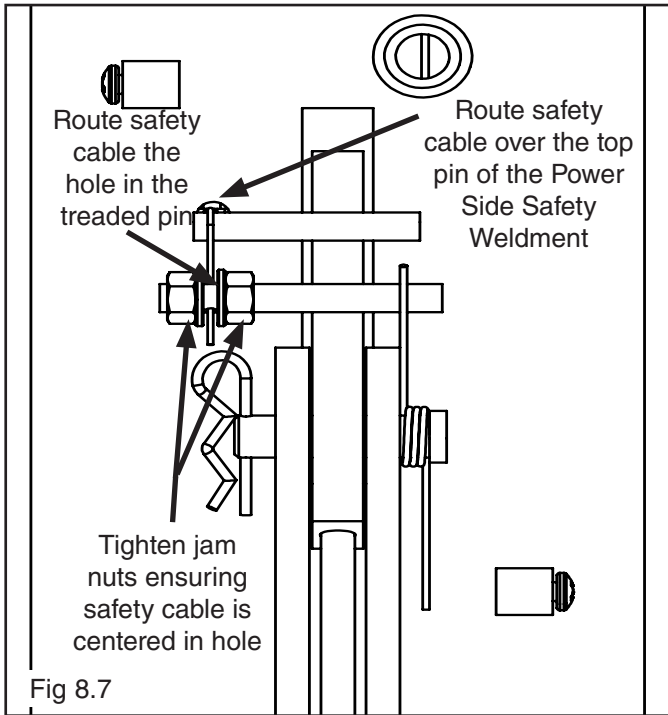

! DANGER

DANGER !
ENSURE THAT BOTH THE POWER SIDE & OFF SIDE SAFETIES ENGAGE PROPERLY PRIOR TO LIFT OPERATION.

8. Operate the power side safety handle, check for proper operation of both Safety Assemblies and adjust cable tension as required.

9. Raise and lock each carriage approximately 28" above the ground. (See Fig. 8.8)

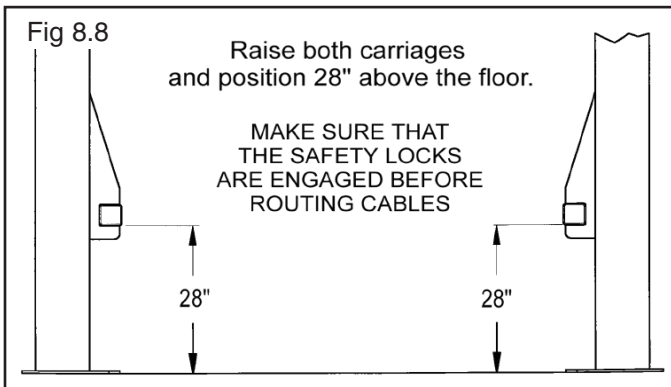

STEP 9 (Installing Hydraulic Lines)

NOTE:
FOR THE WIDE CONFIGURATION, A 13" EXTENSION MUST BE INSTALLED TO THE CROSSOVER HOSE. A JIC TO JIC STRAIGHT FITTING HAS BEEN PROVIDED TO CONNECT THE CROSSOVER HOSE TO THE EXTENSION HOSE IN THE PARTS BOX.

1. Connect the two cylinder hydraulic hoses in line to the tee fitting. Connect the 90° fitting to the tee fitting. Connect the power unit hose to the 90° fitting. (See Fig 9.1)

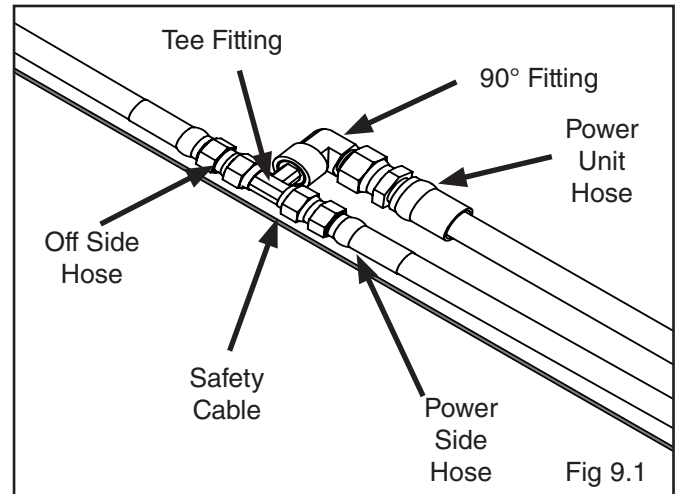

2. Connect the cylinder hoses to the straight fittings on the cylinders. DO NOT use teflon tape on the JIC fitting end. (See Fig 9.2)

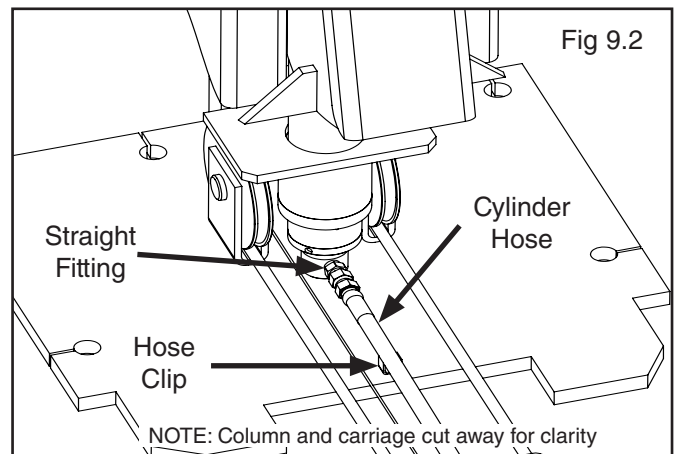

3. Route the power unit hose between the cylinder shaft and the equalizer sheave bracket. Route the hose through the hose clip. Failure to do so may cause damage or injury. (See Fig 9.3)

4. Remove the plastic plug from the power unit power port. Install the 90° power unit fitting with O-ring using teflon tape. (Connect the power unit hose assembly to the 90° hydraulic fitting on the power unit. DO NOT use teflon tape on the JIC hose fittings. (See Fig 9.4)

! WARNING

WARNING !
 WHEN ROUTING HYDRAULIC HOSES THROUGH THE POSTS, ROUTE HOSES THROUGH THE HOSE CLIPS WELDED ON EACH POST. MAKE SURE THAT THE HOSE IS CLEAR OF ANY MOVING PARTS. IT MAY BE NECESSARY TO TIE THE HOSES CLEAR BY USING NYLON TIE STRAPS OR WIRE. FAILURE TO KEEP THE HYDRAULIC HOSES CLEAR MAY RESULT IN THE HYDRAULIC HOSES TO FAIL, WHICH MAY RESULT IN DAMAGE OR PERSONAL HARM.

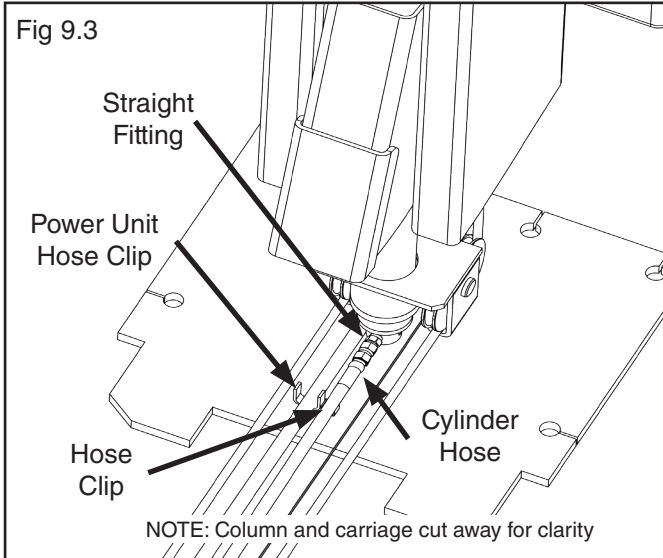

NOTE:
 POWER PORT LOCATION IN HYDRAULIC POWER UNIT MAY VARY. CONFIRM THE LOCATION OF THE POWER PORT ENCLOSED IN THE POWER UNIT DOCUMENTATION.

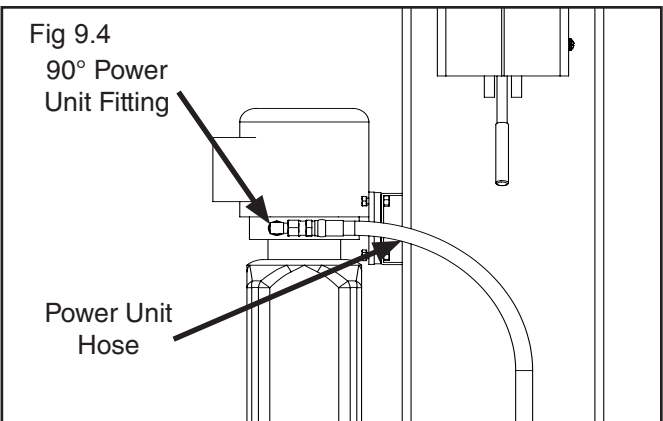

**STEP 10
 (Routing the Equalizer Cables)**

Refer to illustrations on Page 17.

1. Raise and lock each carriage approximately 28" above the ground. (See Fig. 10.1)

! DANGER

DANGER !
 MAKE SURE THAT THE SAFETY LOCKS ON EACH POST ARE FULLY ENGAGED BEFORE ATTEMPTING TO ROUTE EQUALIZER CABLES AND/OR HOSES. CARRIAGES MUST BE EQUAL HEIGHT FROM THE FLOOR BEFORE PROCEEDING.

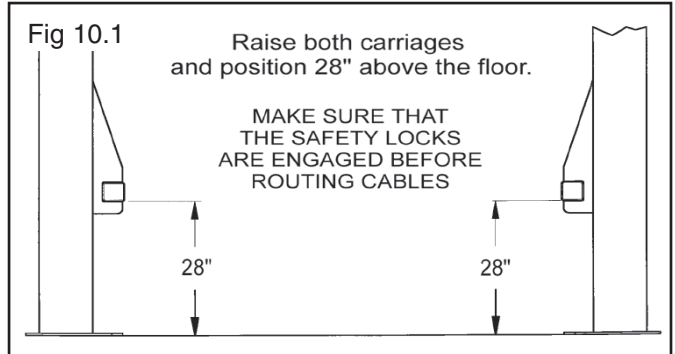

2. With the carriages locked at 28" off the floor, route the threaded end of the equalizer cable across to the opposite side base plate sheave and up through the carriage. (See Fig. 10.2)

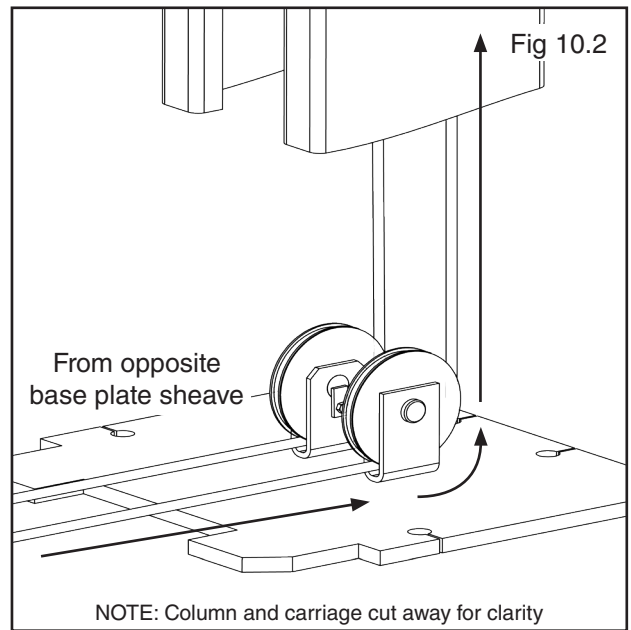

3. Route the threaded end up and over the Top Plate sheave and back down to the carriage and reinstall sheave. (See Fig. 10.3)

NOTE:
 THERE WILL BE INITIAL STRETCHING OF THE CABLES AND/OR WITH INCREASED LOADS. ADJUST THE CABLES AS OUTLINED ABOVE A WEEK AFTER FIRST USE, THEN EVERY THREE TO SIX MONTHS THEREAFTER DEPENDING ON USAGE AND/OR TO COMPENSATE FOR STRETCH.

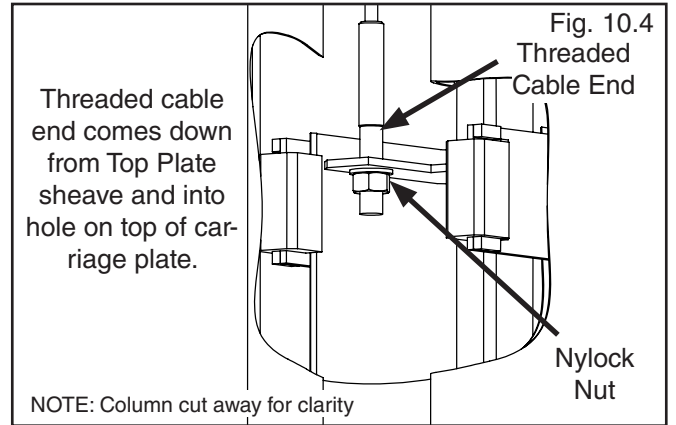
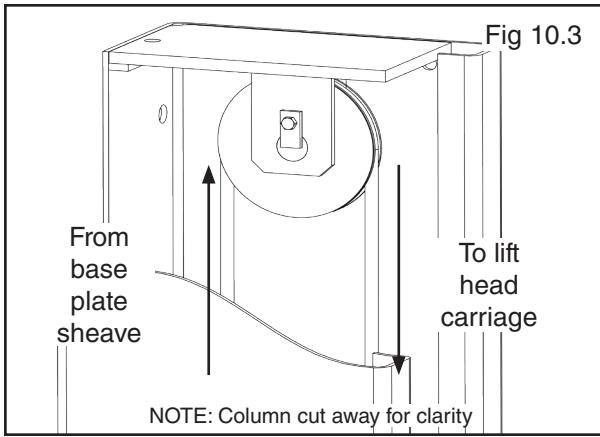

4. Insert the threaded end of the cable through the hole on top of the carriage. Place M18 washer and M18 Nylon nut on threaded cable end. Tighten cable nuts until taut, checking that both cables have equal tension. (See Fig 10.4)

⚠ WARNING

WARNING !
THE EQUALIZER CABLE SHEAVES WILL NEED TO BE REMOVED TO EASE THE ROUTING OF THE EQUALIZER CABLES. BE SURE TO REINSTALL ALL PINS, COVERS, BOLTS AND CLIPS OR SERIOUS DAMAGE OR INJURY MAY OCCUR.

⚠ WARNING

WARNING!
WHEN THE CABLE ADJUSTING NUTS BOTTOM OUT ON THE THREADED END OF THE CABLE CONNECTOR AND THERE IS STILL SLACK IN THE CABLES, THE CABLES HAVE STRETCHED BEYOND THE SAFE USEFUL LENGTH AND NEED TO BE REPLACED WITH FACTORY APPROVED CABLE ASSEMBLIES. DO NOT PLACE WASHERS, SPACERS OR OTHER DEVICES TO "SHORTEN" THE EFFECTIVE CABLE LENGTH AS DAMAGE TO THE LIFT OR INJURY TO PERSONS MAY OCCUR.

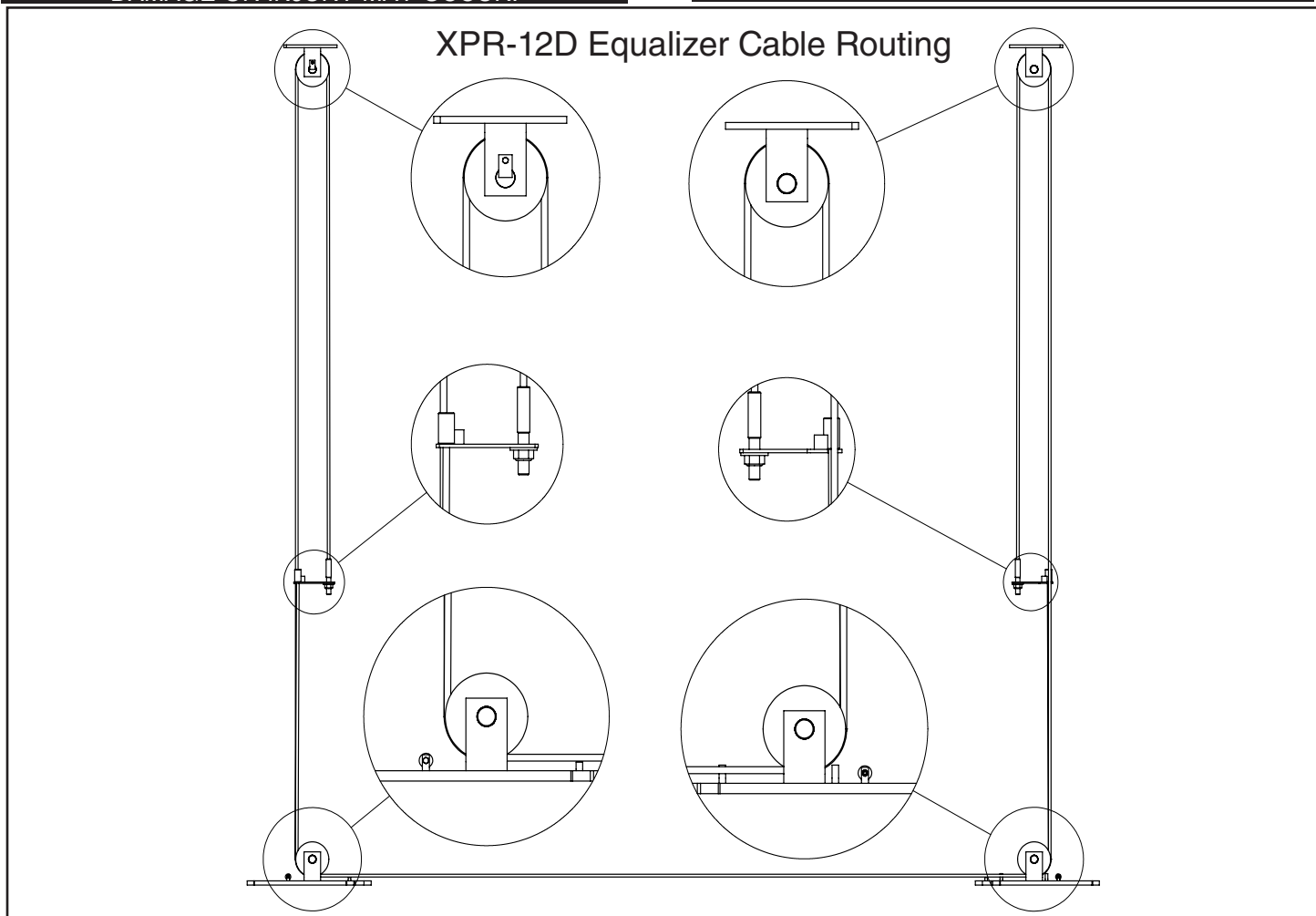

STEP 11 (Installing Floor Plate and Safety Cover)

1. After safeties have been adjusted and checked for proper operation, install and tighten Power Side safety cover and Off Side safety cover mounting screws. (See Fig. 11.1)

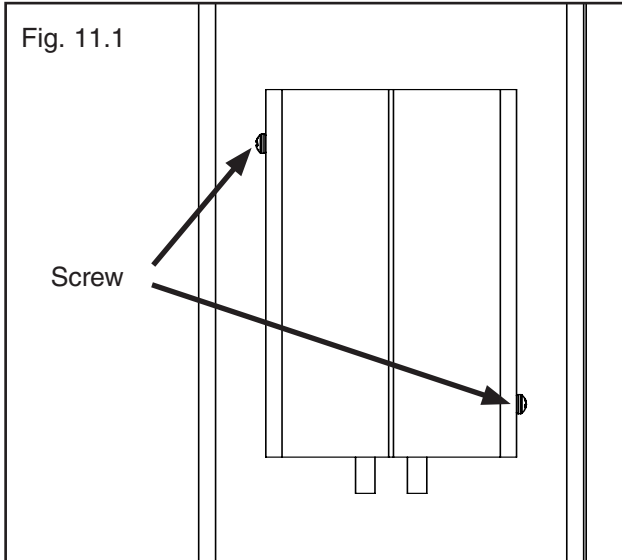

2. Install the floor plate between the columns as shown. (See Fig. 11.2)

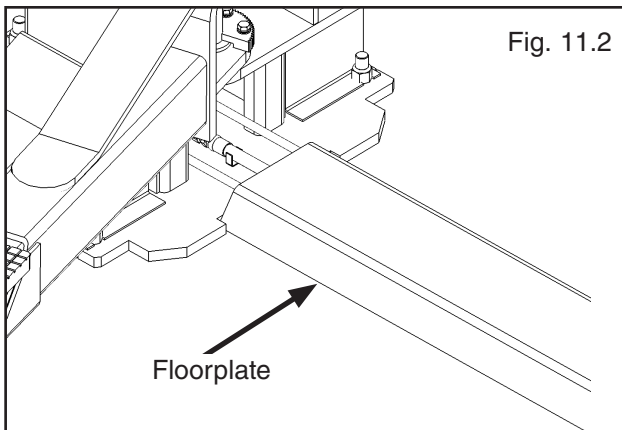

STEP 12 (Installing the Lift Arms)

1. Place the lift arm assemblies in the lift heads.
2. Install the lift head pins into the lift head and through the holes in the arm assembly. (See Fig. 12.1)
3. Install the snap ring into the groove in the lift head pin on under side of the lift head. (See Fig. 12.2)

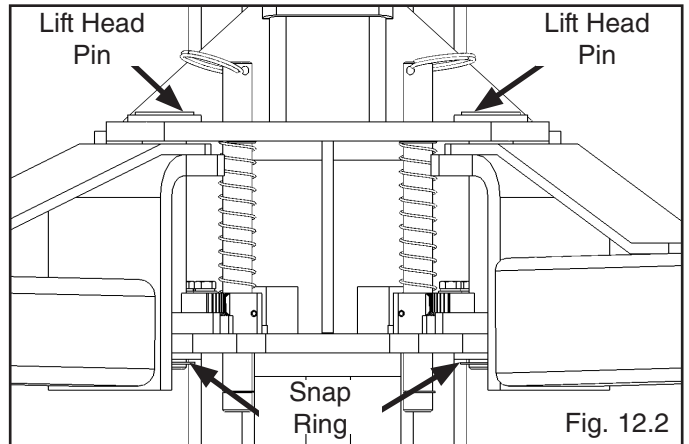
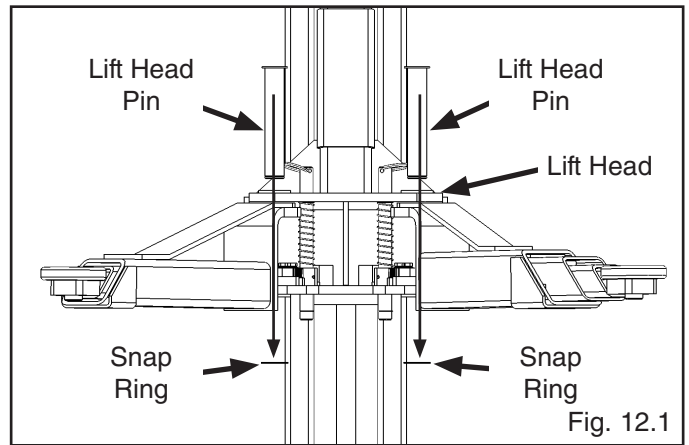

⚠ DANGER

DANGER!
THE ARM RESTRAINT GEARS MUST BE POSITIONED PROPERLY. CONFIRMATION OF PROPER GEAR ENGAGEMENT MUST BE MADE PRIOR TO THE OPERATION OF THE LIFT. PERIODIC INSPECTION IS REQUIRED. FAILURE TO INSPECT THE ARM RESTRAINT GEARS ON ALL FOUR ARMS PROPERLY CAN RESULT IN DAMAGE TO THE VEHICLE OR INJURY AND/OR DEATH.

4. Place each Gear Ring against the Lift Head Pin and align the holes in the Gear Ring with the threaded holes in the Arm Ears. Ensure that the teeth on the Gear Ring mesh smoothly with the teeth on the gears of the Lift Head. (See Fig. 12.3)

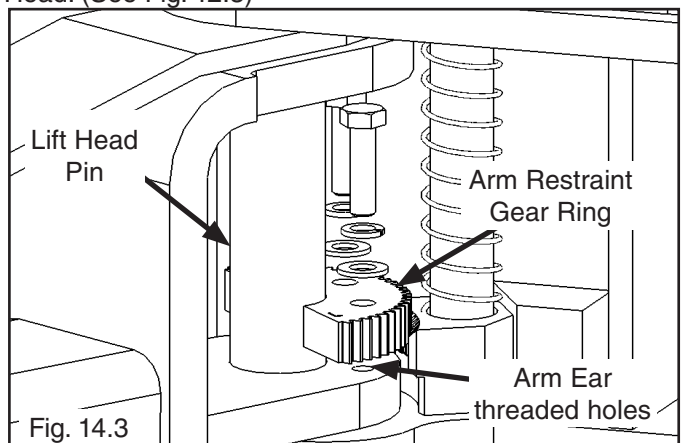

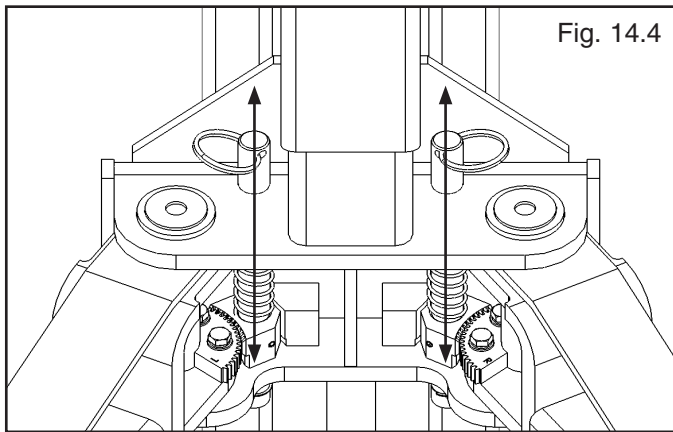

5. Verify the operation of the arm restraints by pulling up on the key ring of the arm restraint pin. Pivot the arms back and forth and test the operation of the arm restraint pin in various positions. (See Fig. 12.4)

6. Ensure that the arms do not move when a force of approximately 100 pounds or less is applied laterally to the fully extended arms.

! DANGER

NOTE:
EACH ARM RESTRAINT ASSEMBLY MUST BE INSPECTED BEFORE EACH AND EVERY TIME THE LIFT IS OPERATED.

DO NOT OPERATE THE LIFT IF ANY OF THE FOUR ARM RESTRAINT SYSTEMS ARE NOT FUNCTIONING PROPERLY.

REPLACE ANY BROKEN COMPONENTS OR COMPONENTS WITH BROKEN TEETH ONLY WITH AUTHORIZED OR APPROVED REPLACEMENT PARTS.

! DANGER

! WARNING

IMPORTANT LEVELING INSTRUCTIONS

Before operating your lift, check to make sure that both "A" and "B" measurements are EQUAL.

The lift arms must be level before operation.

If your lift arms are not level, shim the columns as required.

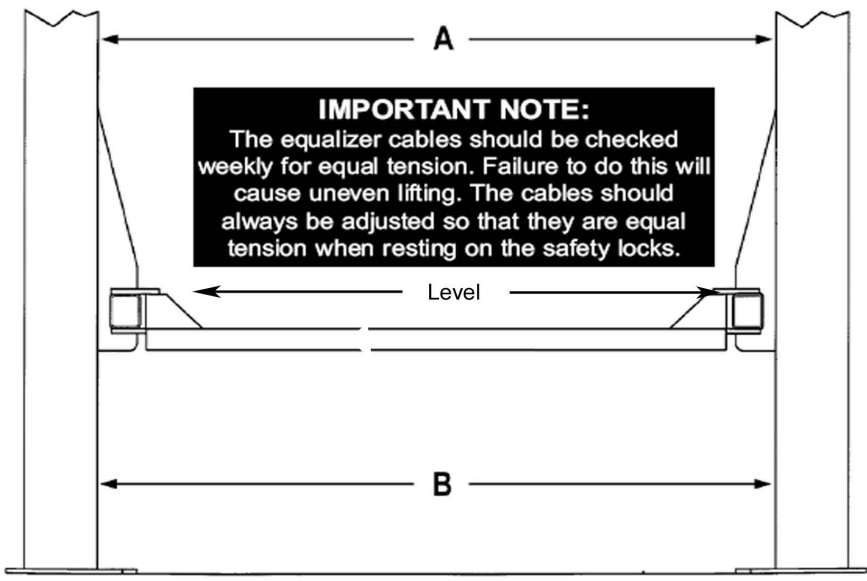

IMPORTANT NOTE:
The equalizer cables should be checked weekly for equal tension. Failure to do this will cause uneven lifting. The cables should always be adjusted so that they are equal tension when resting on the safety locks.

CARRIAGE STOP BOLT INSTALLATION WARNING



WARNING!

YOU MUST RE-INSTALL TOP CARRIAGE-STOP BOLT (SHOWN BELOW). TIGHTEN CARRIAGE-STOP BOLT TO 2-3 FT.-LBS. OF TORQUE UPON FINAL INSTALLATION INSPECTION. THESE INSTRUCTIONS MUST BE FOLLOWED TO ENSURE PROPER INSTALLATION AND OPERATION OF YOUR LIFT. FAILURE TO COMPLY WITH THESE INSTRUCTIONS CAN RESULT IN SERIOUS BODILY INJURY AND/OR DEATH AND/OR VOID PRODUCT WARRANTY. MANUFACTURER WILL ASSUME NO LIABILITY FOR LOSS OR DAMAGE OF ANY KIND, EXPRESSED OR IMPLIED RESULTING FROM IMPROPER INSTALLATION OR USE OF THIS PRODUCT.

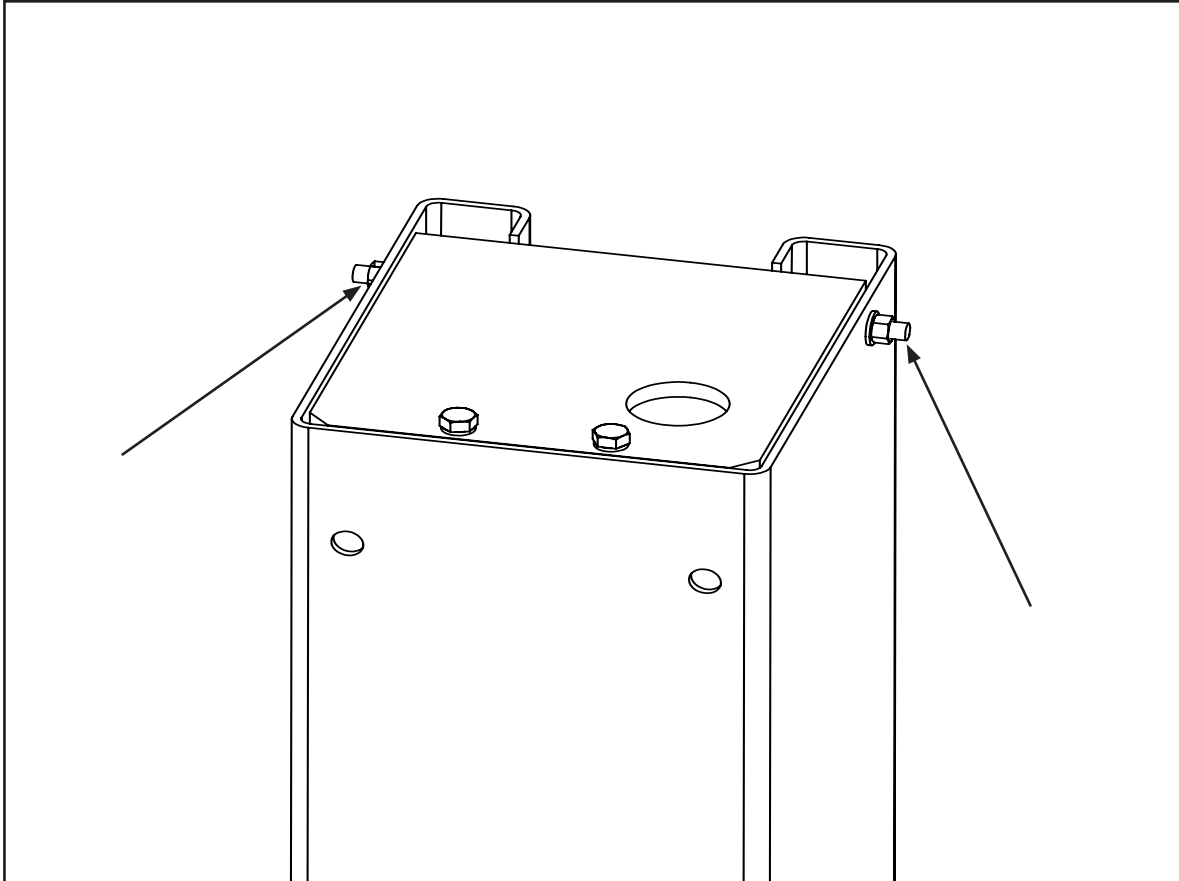



DANGER!

DO NOT PERFORM ANY MAINTENANCE OR INSTALLATION OF ANY COMPONENTS WITH OUT FIRST ENSURING THAT ELECTRICAL POWER HAS BEEN DISCONNECTED AT THE SOURCE OR PANEL AND CANNOT BE RE-ENERGIZED UNTIL ALL MAINTENANCE AND/OR INSTALLATION PROCEDURES ARE COMPLETED.



IMPORTANT POWER-UNIT INSTALLATION NOTES

- DO NOT run power unit without oil. Damage to pump can occur.
- The power unit must be kept dry. Damage to power unit caused by water or other liquids such as detergents, acid etc., is not covered under warranty.
- Improper electrical connection can damage motor and will not be covered under warranty.
- Motor can not run on 50HZ without a physical change in the motor.
- Use a separate breaker for each power unit.
- Protect each circuit with time delay fuse or circuit breaker.
- For 208-230 volt, single phase, use a 25 amp fuse.
- For 208-230 volt, three phase, use a 20 amp fuse.
- For 380-440 volt, three phase, use a 15 amp fuse.

Installation and adjustment.

DO NOT attempt to raise vehicle until a thorough operation check has been completed.

All wiring must be performed by a certified electrician only.

Single Phase

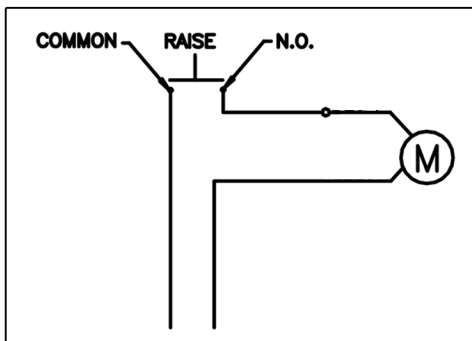

Three Phase

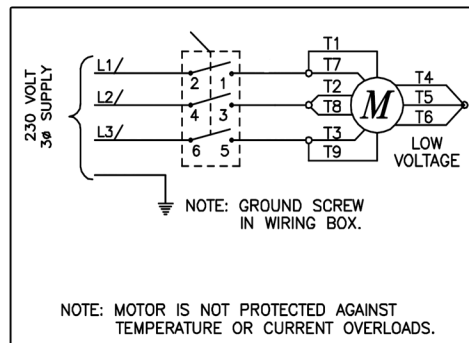

SEE WIRING INSTRUCTIONS AFFIXED TO
MOTOR FOR PROPER WIRING INSTRUCTIONS.

STEP 13 (Power Unit Connection)

1. Have a certified electrician run the power supply to motor. Refer to the data plate found on the motor for proper power supply and wire size.



RISK OF EXPLOSION!

This equipment has internal arcing or parts that may spark and should not be exposed to flammable vapors. Motor should not be located in a recessed area or below floor level. NEVER expose motor to rain or other damp environments. **DAMAGE TO MOTOR CAUSED BY WATER IS NOT COVERED UNDER WARRANTY.**

NOTE:

CAUTION NEVER OPERATE THE MOTOR ON LINE VOLTAGE LESS THAN 208V. MOTOR DAMAGE MAY OCCUR WHICH IS NOT COVERED UNDER WARRANTY. HAVE A CERTIFIED ELECTRICIAN RUN APPROPRIATE POWER SUPPLY TO MOTOR. SIZE WIRE FOR 25 AMP CIRCUIT. SEE MOTOR OPERATING DATA TABLE. USE SEPARATE CIRCUIT FOR EACH POWER UNIT. PROTECT EACH CIRCUIT WITH TIME DELAY FUSE OR CIRCUIT BREAKER. FOR SINGLE PHASE 208-230V, USE 25 AMP FUSE. THREE PHASE 208-240V, USE 25 AMP FUSE. FOR THREE PHASE 400V AND ABOVE, USE 15 AMP FUSE. ALL WIRING MUST COMPLY WITH NECK AND ALL LOCAL ELECTRICAL CODES.

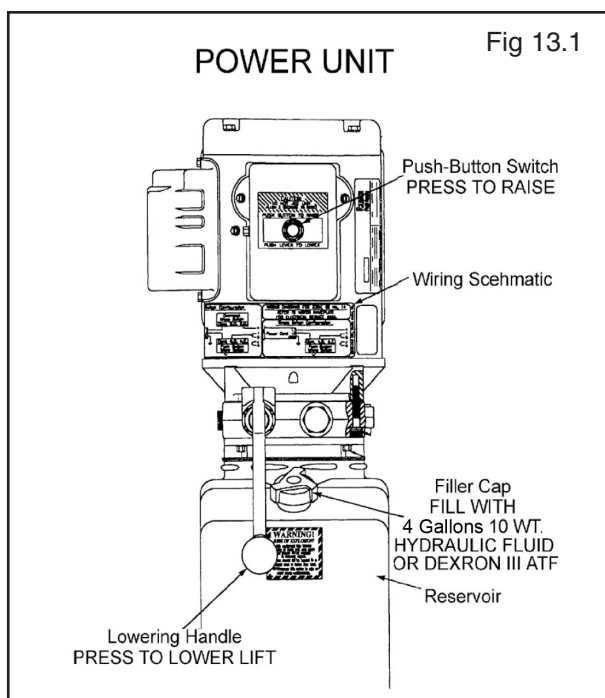

STEP 14 (Lift Start Up / Final Adjustments)



CAUTION!

DURING THE START-UP PROCEDURE, OBSERVE ALL OPERATING COMPONENTS AND CHECK FOR PROPER INSTALLATION AND ADJUSTMENT. DO NOT ATTEMPT TO RAISE VEHICLE UNTIL A THOROUGH OPERATIONAL CHECK HAS BEEN COMPLETED.

1. Make sure the power unit reservoir is full with four (4) gallons of 10-WT hydraulic oil or Dexron-III automatic transmission fluid.
2. Apply light axle grease to the inside of the posts where the slide blocks glide.
3. Test the power unit by pressing the push-button switch. If the motor sounds like it is operating properly, raise the lift and check all hose connections for leaks. If the motor gets hot or sounds peculiar, stop and check all electrical connections.
4. Before proceeding, double-check to make sure all cables are properly positioned within the grooves of ALL sheaves. Make sure all cable sheave retaining pins and/or clips are secure.
5. Check to make sure that all safety locks are cleared and free.
6. Continue to press the button to raise lift until the cables get taut and the lift starts to move.
7. **KEEP HANDS AND FEET CLEAR.** Remove hands and feet from any moving parts. Keep feet clear of lift when lowering. Avoid pinch points.
8. Check all MAIN SAFETY LOCKS to make sure they move freely and spring back to the lock position when released. Lubricate all SAFETY PIVOT points with light spray-oil.
9. Cycle the lift up and down a few times to ensure that the safety locks are engaging uniformly and that the safety release mechanisms are functioning. Re-adjust if necessary.

POST-INSTALLATION CHECK-OFF

- Columns properly shimmed and stable
- Anchor Bolts tightened
- Pivot / Sheave Pins properly attached
- Electric power supply confirmed
- Cables adjusted properly
- Safety Locks functioning properly
- Check for hydraulic leaks
- Oil level
- Lubrication of critical components
- Check for overhead obstructions
- All Screws, Bolts, and Pins securely fastened
- Surrounding area clean
- Operation, Maintenance and Safety Manuals on site.
- Perform an Operational Test with a typical vehicle

STEP 15 (Lubrication)

1. After installation and start-up has been completed, lubricate lift components as described below.
(See Fig. 15.1)

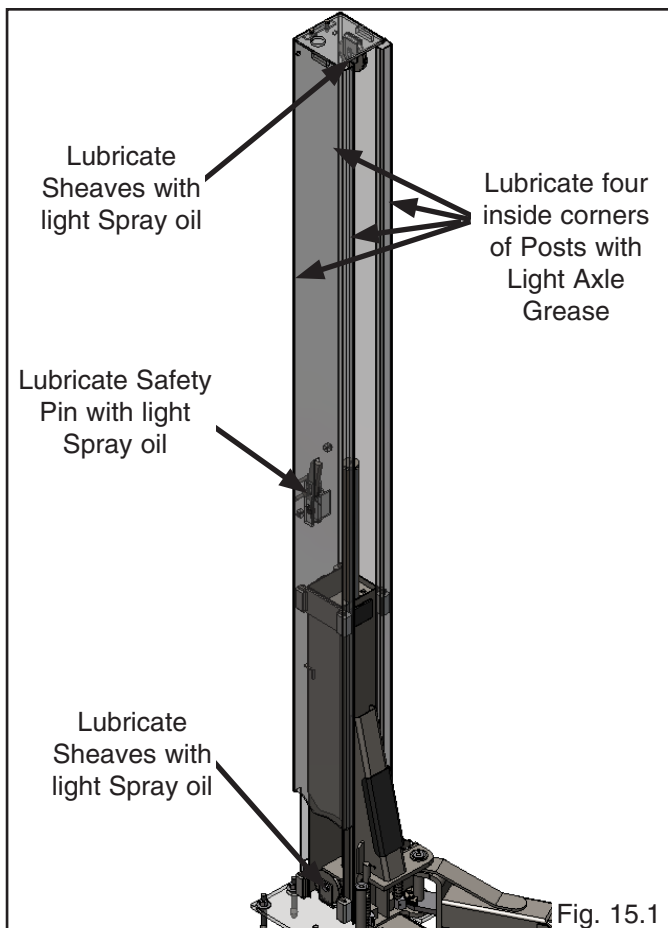

STEP 16 (Bleeding the Cylinders)



DANGER!
THE LIFT WILL MOVE DOWN WHEN BLEEDING
MAKE SURE ALL EQUIPMENT, PERSONNEL, HANDS
AND FEET ARE CLEAR BEFORE BLEEDING

1. After electrical power is connected and oil reservoir is full, press button to raise lift.
2. Continue raising until lift cylinders fully extend to full height. DO NOT continue pressing button after lift reaches full height. Damage to motor can occur if continued.
3. Lower the lift only HALF WAY by pressing the SAFETY RELEASE handle inward then pressing in the DOWN lever on the power unit.
4. With the lift at half height, slowly loosen the BLEED SCREWS located at the top of each cylinder to bleed trapped air. DO NOT completely remove bleed screws. Re-tighten after trapped air has escaped. (See Fig. 16.1)
5. Lower the lift completely by pressing the SAFETY RELEASE handle inward then pressing the DOWN lever on power unit. Wait five minutes and repeat bleeding process one additional time.

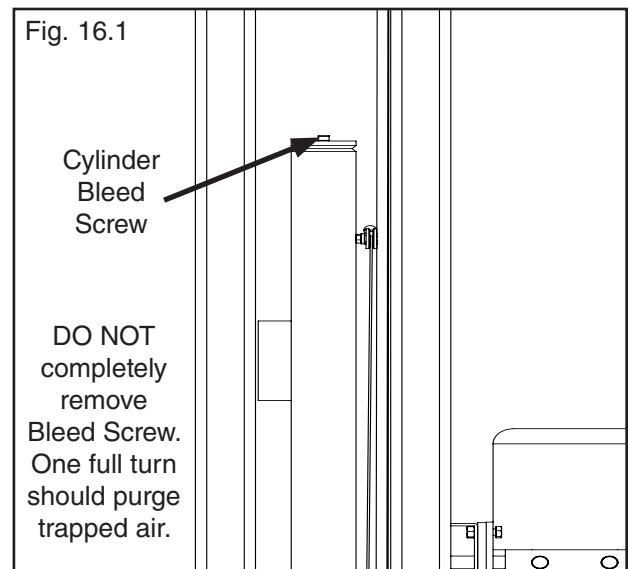

OPTIONAL EQUIPMENT INSTALLATION

Utility Air-Electric Workstation

Utility Station may be mounted on the vertical column of the lift or on a wall.

IMPORTANT: Check State or Local codes for any height requirements for the electrical outlets before mounting.

To mount the Utility Station on a Lift Column, use the Box as a template, mark and drill 11/32" diameter holes. Use 5/16" diameter bolts and lock nuts to secure to the side of the lift.

IMPORTANT: The hole locations are critical to avoid interference with the carriage slide blocks.

For Wall mounting, mount in the same fashion use appropriate hardware for either sheet rock or concrete.

IMPORTANT: All electrical wiring shall comply with all State and Local Codes.

Connect electrical wiring to single phase, 60Hz 115 volt electrical supply using suitable conduit (not supplied). The duplex receptacle must be connected through the GFCI with the input line to the box connected to a circuit breaker or time delay fuse rated at 20 amps. Both receptacles must be grounded to the box.

Connect main air supply to 1/4" ball valve inlet on the Utility Station (Run 3/8" line from compressor or main air system to Utility Station.)

Install Quick Couplers to the 1/4" male fittings on the box. The air supply between the filter and the lubricator will be non-lubricated, used for tire inflation or blowing off. The air outlet on the left side will be lubricated for air tool use.

Regulator Instructions

- Regulate pressure by raising the knob, then turning clockwise to increase and counterclockwise to decrease. Push knob down to lock setting.
- Adjust the oil mist using the screwdriver slot located on top of the lubricator.
- To fill the lubricator, first depressurize the air system, remove the slotted screw plug in the body. Replace the screw before repressurizing.

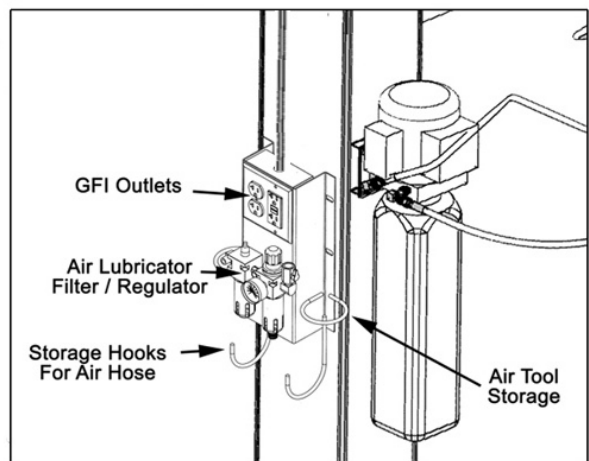
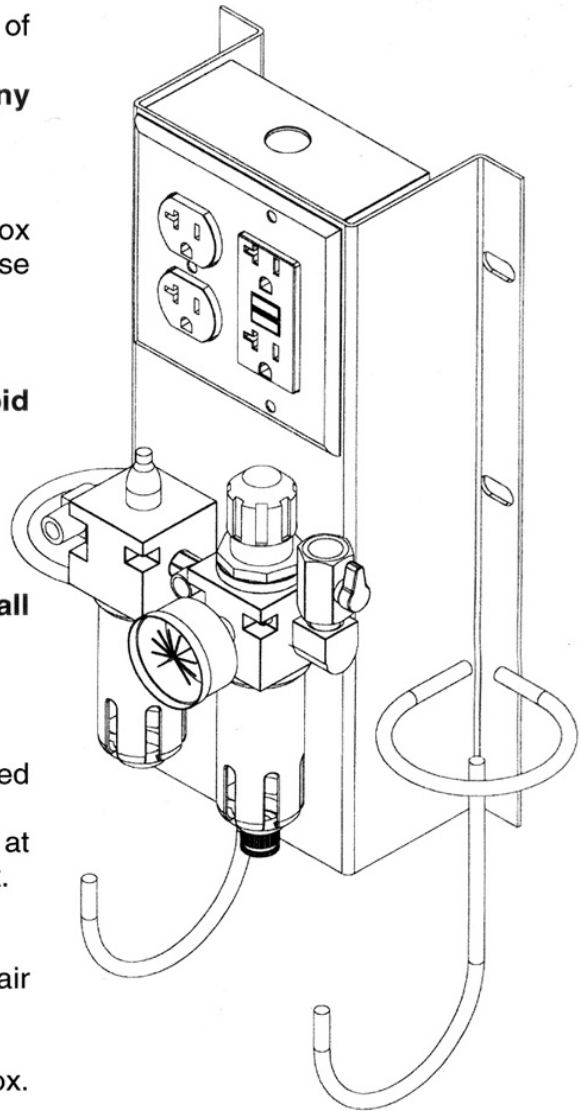

OPTIONAL SCREW PAD ADAPTERS

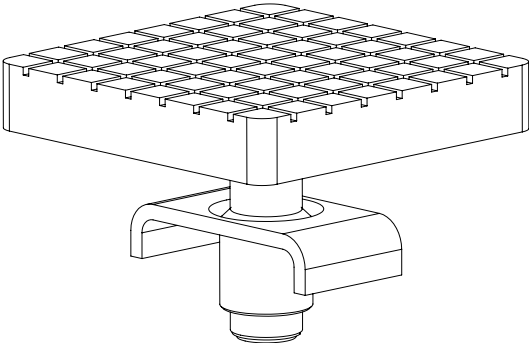

If the lift was provided with Lift Arm Foot Guards, install the shorter Foot Guard on the shorter Arm Assembly and the longer Foot Guard on the longer Arm Assembly.

To install firmly squeeze the ends of the Foot Guard inwards and insert the ends underneath the bent ends of the arm support. Release to allow the Foot Guard to spring into place. Check to be sure that Foot Guard is firmly in place.

Repeat this step for each Arm Assembly Foot Guard.

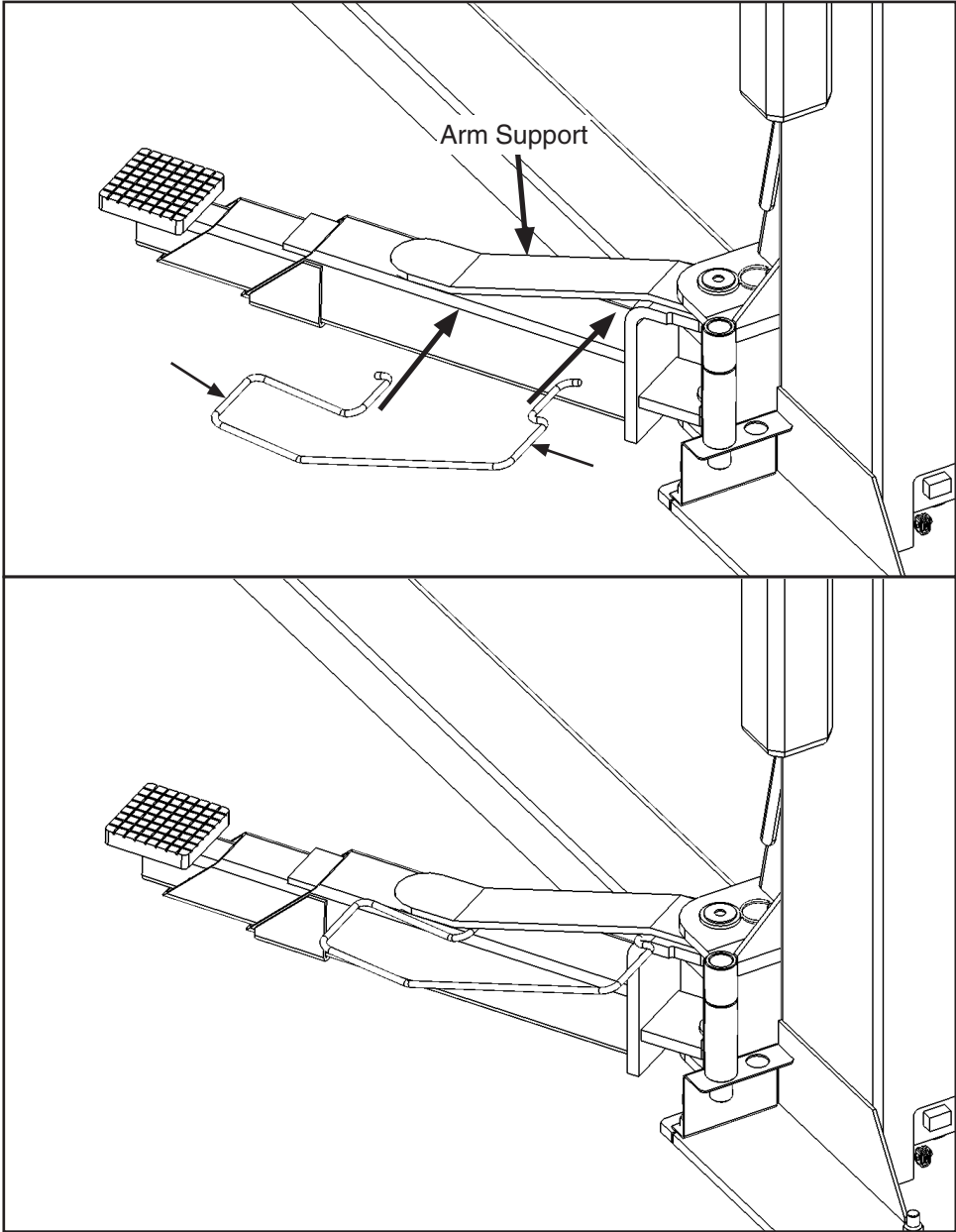

Optional Equipment available through your Authorized BendPak Dealer.

STEP 17 (Operation Instructions)

OWNER/EMPLOYER RESPONSIBILITIES

The Owner/Employer:

- Shall ensure that lift operators are qualified and that they are trained in the safe use and operation of the lift using the manufacturer's operating instructions; ALI/SM01-1, ALI Lifting it Right safety manual; ALI/ST-90 ALI Safety Tips card; ANSI/ALI ALOIM-2000, American National Standard for Automotive Lifts-Safety Requirements for Operation, Inspection and Maintenance; ALI/WL Series, ALI Uniform Warning Label Decals/Placards; and in the case of frame engaging lifts, ALI/LP-GUIDE, Vehicle Lifting Points/Quick Reference Guide for Frame Engaging Lifts.

- Shall establish procedures to periodically inspect the lift in accordance with the lift manufacturer's instructions or ANSI/ALI ALOIM-2000, American National Standard for Automotive Lifts-Safety Requirements for Operation, Inspection and Maintenance; and The Employer shall ensure that lift inspectors are qualified and that they are adequately trained in the inspection of the lift.

- Shall establish procedures to periodically maintain the lift in accordance with the lift manufacturer's instructions or ANSI/ALI ALOIM-2000, American National Standard for Automotive Lifts-Safety Requirements for Operation, Inspection and Maintenance; and The Employer shall ensure that lift maintenance personnel are qualified and that they are adequately trained in the maintenance of the lift.

- Shall maintain the periodic inspection and maintenance records recommended by the manufacturer or ANSI/ALI ALOIM-2000, American National Standard for Automotive Lifts-Safety Requirements for Operation, Inspection and Maintenance.

- Shall display the lift manufacturer's operating instructions; ALI/SM 93-1, ALI Lifting It Right safety manual; ALI/ST-90 ALI Safety Tips card; ANSI/ALI ALOIM-2000, American National Standard for Automotive Lifts-Safety Requirements for Operation, Inspection and Maintenance; and in the case of frame engaging lifts, ALI/LP-GUIDE, Vehicle Lifting Points/Quick Reference Guide for Frame Engaging Lifts; in a conspicuous location in the lift area convenient to the operator.

- Shall provide necessary lockout/tagout means for energy sources per ANSI Z244.1-1982 (R1993), Safety Requirements for the Lockout/Tagout of Energy Sources, before beginning any lift repairs.

- Shall not modify the lift in any manner without the prior written consent of the manufacturer.



LIFT OPERATION SAFETY

- **DAILY** inspect your lift. Never operate if it malfunctions or if it has broken or damaged parts. Use only qualified lift service personnel and genuine BendPak parts to make repairs.

- **THOROUGHLY** train all employees in use and care of lift, using manufacturer's instructions and "Lifting It Right" and "Safety Tips" supplied with the lift.

- **NEVER** allow unauthorized or untrained persons to position vehicle or operate lift.

- **PROHIBIT** unauthorized persons from being in shop area while lift is in use.

- **DO NOT** permit anyone on lift or inside vehicle when it is either being raised or lowered.

- **ALWAYS** keep area around lift free of tools, debris, grease and oil.

- **NEVER** overload lift. Capacity of lift is shown on nameplate affixed to the lift.

- **DO NOT** stand in front of the vehicle while it is being positioned in lift bay.

- **DO NOT** hit or run over lift arms or adapters. This could damage lift or vehicle. Before driving vehicle into lift bay, position arms and adapters to provide unobstructed entrance onto lift.

LIFT OPERATION SAFETY (CONT'D)

- **ALWAYS** load vehicle on lift carefully. Position the lift adapters to contact at the vehicle manufacturer's recommended lift points. Raise lift until adapters contact vehicle. Check adapters for secure contact with vehicle. Raise lift to desired working height. (See Fig.17.1)

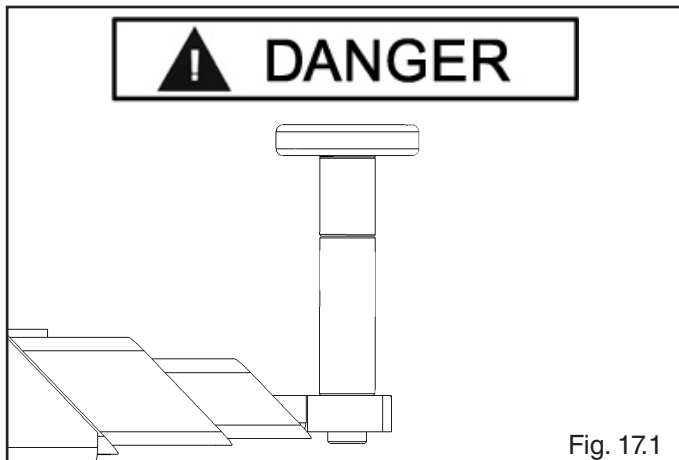

- **DO NOT** block open or override self-closing lift controls; they are designed to return to the "Off" or Neutral position when released.
- **DO NOT** remove or disable arm restraints.
- **ALWAYS** remain clear of lift when raising or lowering vehicles.
- **ALWAYS** use safety stands when removing or installing heavy components.
- **DO NOT** go under raised vehicle if safety locks are not engaged.



DANGER!

VISUALLY CONFIRM THAT ALL PRIMARY SAFETY LOCKS ARE ENGAGED BEFORE ENTERING WORK AREA. SUSPENSION COMPONENTS USED ON THIS LIFT ARE INTENDED TO RAISE AND LOWER LIFT ONLY AND ARE NOT MEANT TO BE LOAD HOLDING DEVICES. REMAIN CLEAR OF ELEVATED LIFT UNLESS VISUAL CONFIRMATION IS MADE THAT ALL PRIMARY SAFETY LOCKS ARE FULLY ENGAGED AND THE LIFT IS LOWERED ONTO THE SAFETY LOCKS, REFER TO INSTALLATION/ OPERATION MANUAL FOR PROPER SAFETY LOCK PROCEDURES AND/OR FURTHER INSTRUCTION.

- **NEVER LEAVE LIFT IN ELEVATED CONDITION** unless all Safety Locks are engaged.
- **AVOID** excessive rocking of vehicle while on lift.
- **ALWAYS CLEAR AREA** if vehicle is in danger of falling.



WARNING!

WHEN LOWERING THE LIFT PAY CAREFUL ATTENTION THAT ALL PERSONNEL AND OBJECTS ARE KEPT CLEAR. ALWAYS KEEP A VISUAL LINE OF SITE ON THE LIFT AT ALL TIMES. ALWAYS MAKE SURE THAT ALL LOCKS ARE DISENGAGED. IF ONE OF THE LOCKS INADVERTENTLY LOCKS ON DESCENT THE LIFT AND/OR VEHICLE MAY DISRUPT CAUSING PERSONAL INJURY OR DEATH.

- **ALWAYS REMOVE** tool trays, stands, etc. before lowering lift.
- **ALWAYS RELEASE** safety locks before attempting to lower lift.
- **ALWAYS POSITION** the lift arms and adapters to provide an unobstructed exit before removing vehicle from lift area.

TO RAISE THE LIFT



WARNING!

TO AVOID PERSONAL INJURY AND/OR PROPERTY DAMAGE, PERMIT ONLY TRAINED PERSONNEL TO OPERATE LIFT. AFTER REVIEWING THESE INSTRUCTIONS, PRACTICE USING LIFT CONTROLS BY RUNNING THE LIFT THROUGH A FEW UNLOADED CYCLES BEFORE LOADING VEHICLE ON LIFT. ALWAYS LIFT THE VEHICLE USING ALL FOUR ADAPTERS. NEVER RAISE JUST ONE END, ONE CORNER, OR ONE SIDE OF VEHICLE.

1. Before Loading: Lift must be fully lowered and service bay clear of all personnel before the vehicle is brought on lift with the swing arms set to the full drive-thru position.
2. Loading: Swing arms under vehicle and position adapters at vehicle manufacturer's recommended lift points. Use height extenders or optional frame-cradle adapters when necessary to ensure good contact. (See Fig 17.2-17.3)
3. Some vehicles may have the manufacturer's Service Garage Lift Point locations identified by triangle shape marks on the undercarriage (reference ANSI/SAE J2184-1992). Also, there may be a label located on the right front door jamb area showing specific vehicle lift points.

LIFT OPERATION SAFETY (CONT'D)

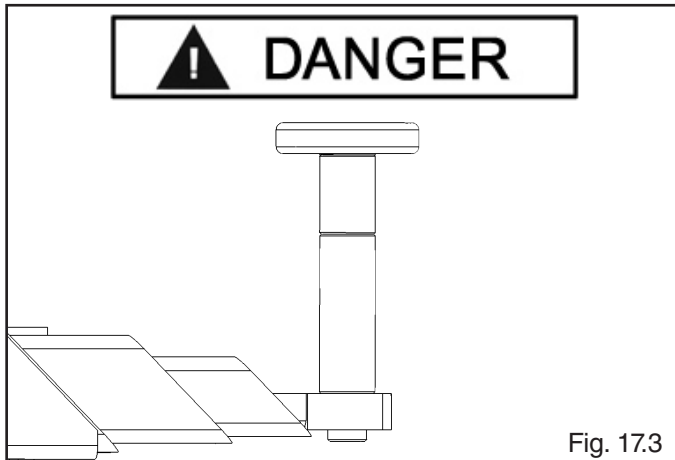
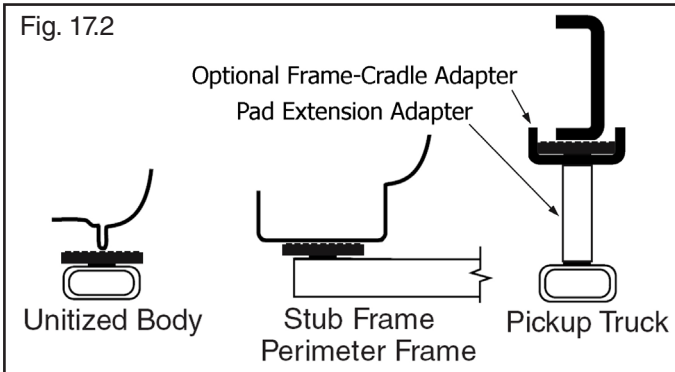

WARNING!
MANY SPECIALTY OR MODIFIED VEHICLES CANNOT BE RAISED ON A TWO-POST FRAME ENGAGING LIFT. CONTACT VEHICLE MANUFACTURER FOR RAISING OR JACKING DETAILS.

4. Position vehicle for proper weight distribution arms under vehicle to allow adapters to contact at the manufacturer's recommended pick up points.

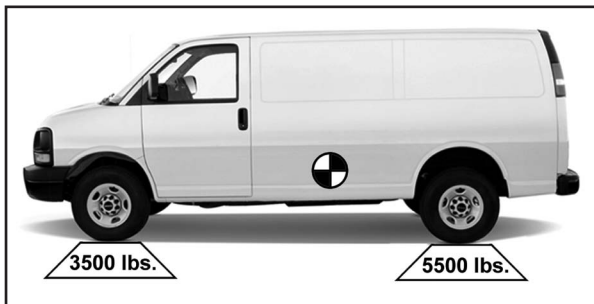

5. If the specific vehicle lift points are not identified, refer to the VEHICLE CENTER OF BALANCE instructions found on our website at

<http://www.bendpak.com/support/balancing-safety/>

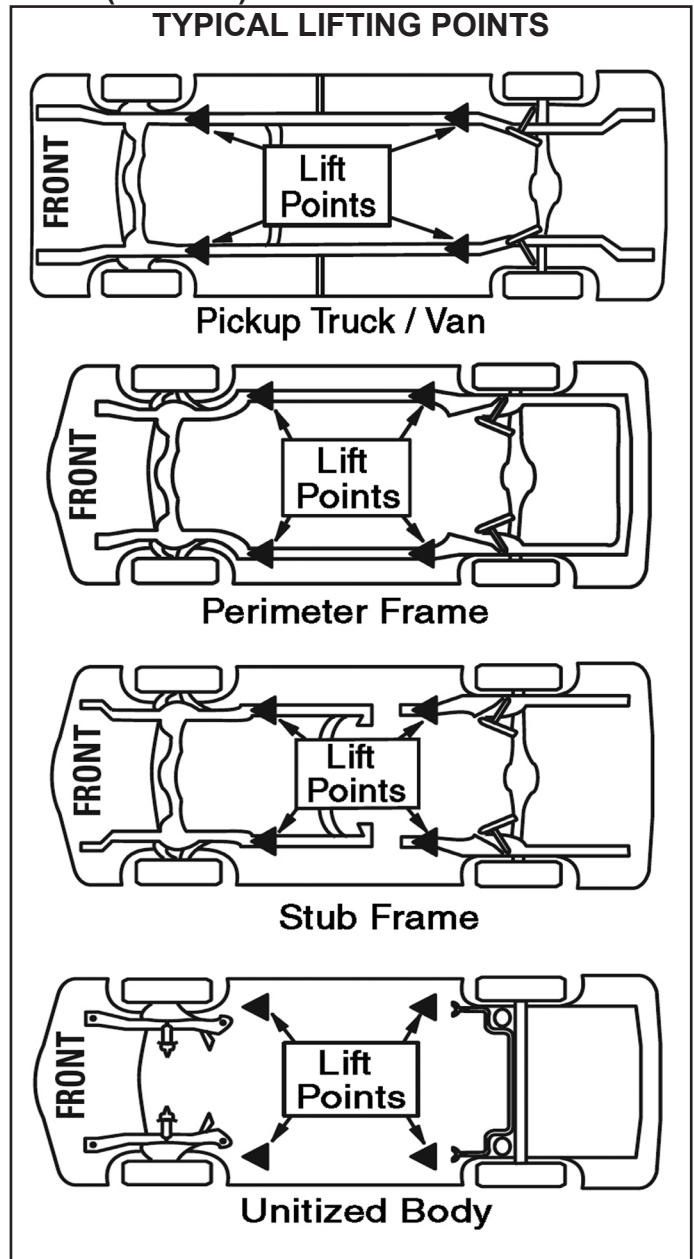

6. Push the **RAISE** button or rotate the control switch on the power unit.

NOTE:
ALLOW (2) SECONDS BETWEEN MOTOR STARTS. FAILURE TO COMPLY MAY CAUSE MOTOR BURNOUT.

7. Stop before making contact with vehicle. Check arm restraint pins for engagement. If required, slightly move arm to allow restraint gear and pawl to mesh. **DO NOT** hammer arm restraint pin down as this will damage the restraint gear teeth.
8. Raise vehicle until tires clear the floor.
9. Stop and check adapters for secure contact at vehicle manufacturer's recommended lift points.

LIFT OPERATION SAFETY (CONT'D) TO LOWER THE LIFT

10. Continue to raise to desired height only if vehicle is secure on lift.

11. **DO NOT** go near or under a raised vehicle if all four adapters are not in secure contact with vehicle at vehicle manufacturer's recommended lift points.

12. Repeat entire loading and raising procedures if required.

13. Lower lift onto safety locks.



DANGER!

VISUALLY CONFIRM THAT ALL PRIMARY SAFETY LOCKS ARE ENGAGED BEFORE ENTERING WORK AREA. SUSPENSION COMPONENTS USED ON THIS LIFT ARE INTENDED TO RAISE AND LOWER LIFT ONLY AND ARE NOT MEANT TO BE LOAD HOLDING DEVICES. REMAIN CLEAR OF ELEVATED LIFT UNLESS VISUAL CONFIRMATION IS MADE THAT ALL PRIMARY SAFETY LOCKS ARE FULLY ENGAGED AND THE LIFT IS LOWERED ONTO THE SAFETY LOCKS, REFER TO INSTALLATION /OPERATION MANUAL FOR PROPER SAFETY

- **DO NOT** enter work area or go under vehicle if safety locks are not engaged.
- **CLEAR AREA** if vehicle is in danger of falling.
- **DO NOT** position yourself between a wall and the lift. If the vehicle falls in that direction, you may be severely injured or killed.
- Before attempting to lift pickup trucks or other truck frame vehicles, be sure that:
 - ◆ Vehicle frame is strong enough to support its weight and has not been weakened by modification or corrosion.
 - ◆ Vehicle individual axle weight does not exceed one-half lift capacity.
 - ◆ Adapters are in secure contact with frame at vehicle manufacturers recommended lift points.
 - ◆ Vehicle is stable on lift and the center of gravity is NOT off balance.
 - ◆ The overhead switch bar will contact the highest point on the vehicle.

WHILE USING LIFT

- Avoid excessive rocking of vehicle while on lift.
- Always use safety stands as needed or when removing or installing heavy components.



WARNING!

WHEN LOWERING THE LIFT PAY CAREFUL ATTENTION THAT ALL PERSONNEL AND OBJECTS ARE KEPT CLEAR. ALWAYS KEEP A VISUAL LINE OF SITE ON THE LIFT AT ALL TIMES. ALWAYS MAKE SURE THAT ALL LOCKS ARE DISENGAGED. IF ONE OF THE LOCKS INADVERTENTLY LOCKS ON DESCENT THE LIFT AND/OR VEHICLE MAY DISRUPT CAUSING PERSONAL INJURY OR DEATH.

1. Remove all tools or other objects from the lift area.
2. Raise lift off safety locks. Make sure you raise the lift by at least two inches to allow adequate clearance for the locks to clear.
3. Push safety lock release handle fully and hold.
4. Push LOWERING valve handle to lower. Note: Both SAFETY LOCK release and LOWERING valve handles must be held down simultaneously to lower lift. Do not override self-closing lift controls.
5. Remain clear of lift when lowering vehicle. Observe pinch point warning decal instructions.
6. Remove adapters from under vehicle and swing arms to full drive-thru position before moving vehicle.
7. If lift is not operating properly, DO NOT use until adjustment or repairs are made by qualified lift service personnel.

MAINTENANCE INSTRUCTIONS



CAUTION!

IF YOU ARE NOT COMPLETELY FAMILIAR WITH AUTOMOTIVE LIFT MAINTENANCE PROCEDURES; STOP AND CONTACT THE MANUFACTURER FOR INSTRUCTIONS. TO AVOID PERSONAL INJURY, PERMIT ONLY QUALIFIED PERSONNEL TO PERFORM MAINTENANCE ON THIS EQUIPMENT.

- Always keep bolts tight. Check periodically.
- Always keep lift components clean.
- Always if oil leakage is observed, call local service representative.

- Always replace ALL FAULTY PARTS before lift is put back into operation.
- Daily: Make a visual inspection of ALL MOVING PARTS and check for excessive signs of wear.
- Daily: Check safety locks to ensure they are in good operating condition.
- Daily: Check cables and sheaves for wear. Replace worn parts as required with genuine BendPak parts.
- Daily: Inspect adapters for damage or excessive wear. Replace as required with genuine BendPak parts.
- Weekly: Lubricate all sheaves and rollers with general purpose oil.
- Weekly: Check all cable connections, bolts and pins to ensure proper mounting.
- Monthly: Check equalizer cable tension. Adjust per lift installation instructions.
- Monthly: Lubricate locking latch shafts. Push latch handle several times for oil to penetrate pivot points.
- Every 3 Months: Check anchor bolt torque. Anchors should be torqued to 90 ft/lbs.
- Semi-Annually: Check fluid level of lift power unit and refill if required per lift installation instructions.
- Replace all caution, warning or safety related decals on the lift if unable to read or missing. Reorder labels from BendPak.
- Refer to ANSI/ALI ALOIM booklet for periodic inspection checklist and maintenance log sheet.

! WARNING

Make sure vehicle is neither front nor rear heavy and select the proper configuration for the vehicle to be lifted (symmetric/asymmetric) as shown below. Center of balance should be midway between adapters.

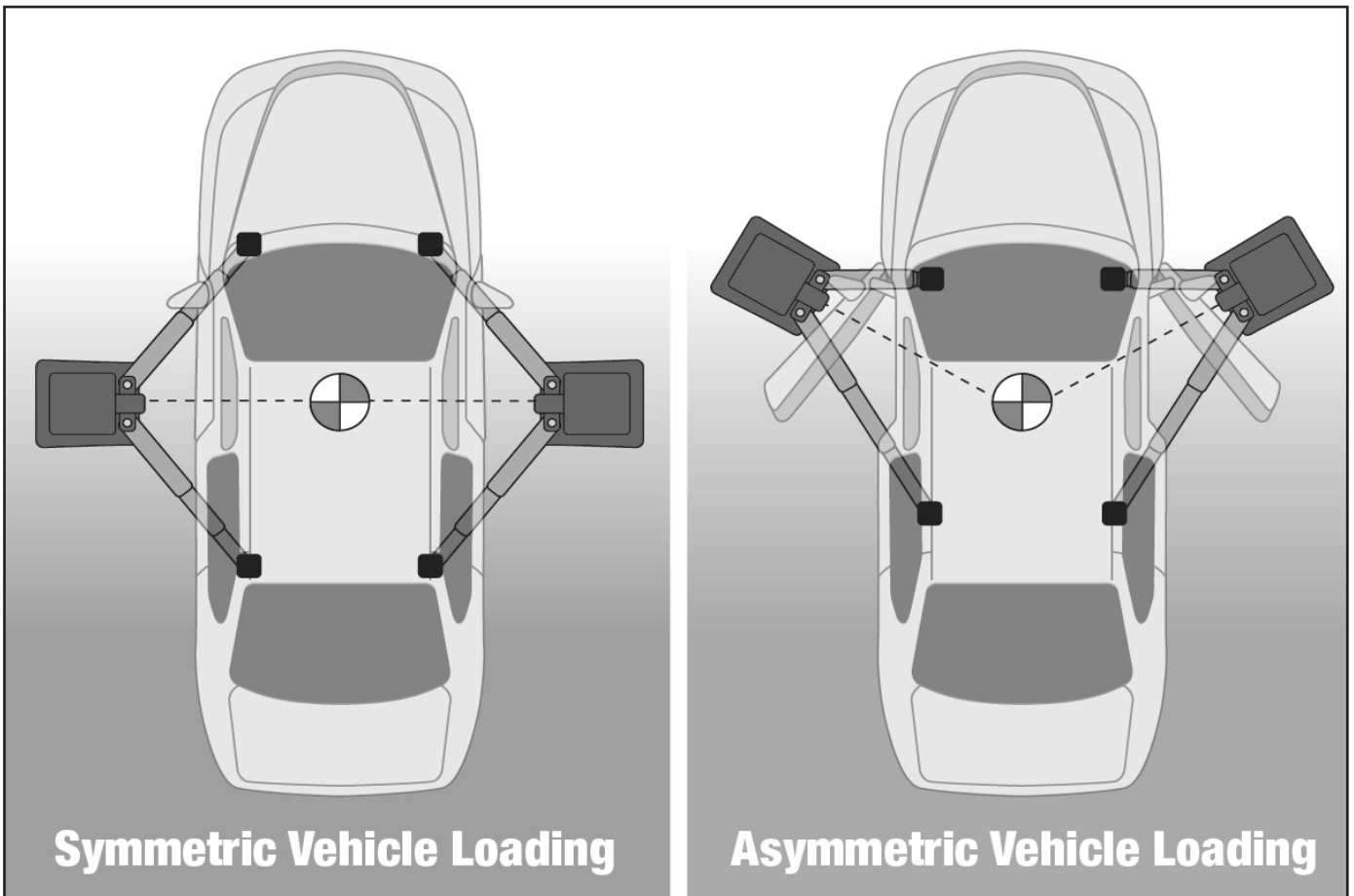

TO RAISE LIFT

- ◆ Read operating and safety manuals before using lift.
- ◆ Always lift a vehicle according to the manufacturers recommended lifting points.
- ◆ Position vehicle between posts.
- ◆ Adjust swing arms so that the vehicle is positioned with the center of gravity midway between pads.
- ◆ Use truck adapters as needed. Never exceed 9" of pad height.
- ◆ **NEVER** use lift pad assemblies without rubber slip over pads in place.
- ◆ Raise the vehicle by depressing button until the vehicle just lifts off the ground. Re-check to make sure the vehicle is secure and all locking pins are lock in place.
- ◆ Raise vehicle to desired height. Lower vehicle onto nearest safety,
- ◆ Always ensure safeties are engaged before any attempt is made to work on or near vehicle.

TO LOWER THE LIFT

- ◆ First raise the lift clear to the safeties.
- ◆ Release safeties by pulling on the safety handle.
- ◆ Be sure tool trays, stands or personnel are cleared from under the vehicle.
- ◆ Lower vehicle by activating lowering handle on power unit.
- ◆ Before removing vehicle from lift; position lift arms and supports to provide an unobstructed exit.
- ◆ **NEVER**, drive over lift arms.

REQUIRED MONTHLY MAINTENANCE

- ◆ Check all arm adjusting locks for proper operation.
- ◆ Check all cables connections, bolts and pins to insure proper mounting and torque.
- ◆ Visually inspect safeties for proper operation.
- ◆ Lubricate posts with grease.
- ◆ Inspect all anchors bolts and retighten if necessary.
- ◆ Check all posts for squareness and plumb.
- ◆ Inspect all pivot arms pins making sure they are properly secure.
- ◆ Check equalizer cable tension, and adjust if necessary.
- ◆ If lift is equipped with over head microswitch, check for proper operation.



1. **WARNING!** If cement anchor bolts are loose or any component of the lift is found to be defective, **DO NOT USE THE LIFT!!**
2. Never operate the lift with any person or equipment below the vehicle.
3. Never exceed the rated lift capacity.
4. Always ensure the safeties are engaged before any attempt is made to work on or near the vehicle.
5. Never leave lift in elevated position unless the safeties are engaged.
6. Do not permit electric motor to get wet! Motor damage caused by dampness is not covered under warranty.

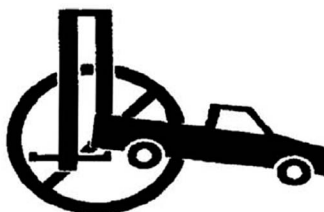

NEVER LIFT ANY VEHICLE IN ANY MANNER WITH LESS THAN ALL FOUR (4) ARMS. RATED CAPACITY OF EACH LIFT ARM IS NO GREATER THAN ONE FOURTH (1/4) OF THE OVERALL LIFT CAPACITY.



WIRE ROPE INSPECTION AND MAINTENANCE

◆ Lifting cables should be replaced every three - five years or when visible signs of damage are apparent. **DO NOT USE LIFT WITH DEFECTIVE / WORN CABLES.**

◆ Lifting cables should be maintained in a well-lubricated condition at all times. Wire rope is only fully protected when each wire strand is lubricated both internal and external. Excessive wear will shorten the life of the wire rope. The factory suggested wire rope lubricant that penetrates to the core of the rope and provides long-term lubrication between each individual strand is 90-WT gear oil or ALMASOL® Wire Rope Lubricant. In order to make sure that the inner layers of the rope remain well lubricated, lubrication should be carried out at intervals not exceeding three months during operation.

◆ All sheaves and guide rollers in contact with the moving rope should be given regular visual checks for surface wear and lubricated to make sure that they run freely. This operation should be carried out at appropriate intervals generally not exceeding three months during operation. For all sheave axles, the factory recommends standard wheel bearing grease. For all sheaves and/or guide rollers, the factory recommends 90-WT gear oil or similar heavy lubricant applied by any method including pump / spray dispensing, brush, hand and/or swabbing.

HOW OFTEN TO INSPECT

◆ Lifting cables should be visually inspected at least once each day when in use, as suggested by American Petroleum Institute (API) RP54 guidelines.

◆ Any lifting cables that have met the criteria for removal must be immediately replaced.

WHEN TO REPLACE LIFTING CABLES DUE TO BROKEN WIRES

◆ Lifting cables should be removed from service when you see six randomly distributed broken wires within any one lay length, or three broken wires in one strand within one lay length.

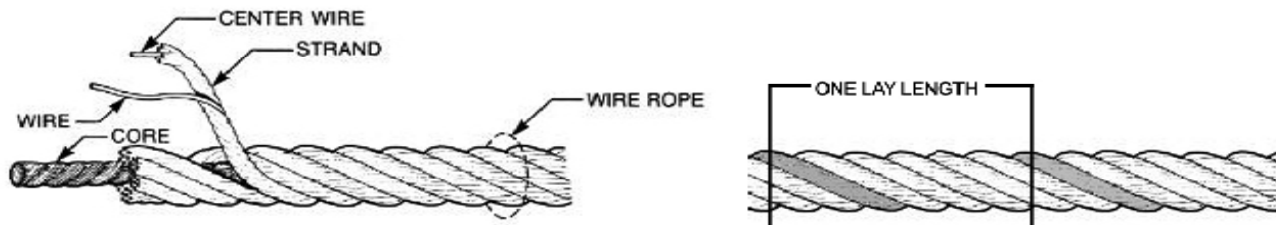

The three basic components of a typical wire rope.

OTHER REASONS TO REPLACE LIFTING CABLES

- ◆ Corrosion that pits the wires and/or connectors.
- ◆ Evidence of kinking, crushing, cutting, bird-caging or a popped core.
- ◆ Wear that exceeds 10% of a wire's original diameter.
- ◆ Evidence of heat damage.

HOW TO FIND BROKEN WIRES

◆ The first step is to relax your rope to a stationary position and move the pick-up points off the sheaves. Clean the surface of the rope with a cloth — a wire brush, if necessary — so you can see any breaks.

◆ Flex the rope to expose any broken wires hidden in the valleys between the strands.

◆ Visually check for any broken wires. One way to check for crown breaks is to run a cloth along the rope to check for possible snags.

◆ With an awl, probe between wires and strands and lift any wires that appear loose. Evidence of internal broken wires may require a more extensive rope examination.

! WARNING

WIRE ROPE INSPECTION AND MAINTENANCE

- Lifting cables should be replaced every three years or when visible signs of damage are apparent. **DO NOT USE LIFT WITH DEFECTIVE: WORN CABLES.**
- Wire rope should be maintained in a well-lubricated condition at all times. Wire rope is only fully protected when each wire strand is lubricated both internally and externally. Excessive wear will shorten the life of the wire rope. The factory suggested wire rope lubricant that penetrates to the core of the rope and provides long term lubrication between each individual strand is **AMSOIL Synthetic Open Gear and Wire Rope Compound** or **90WT** gear oil or similar heavy lubricant. In order to make sure that the inner layers of the rope remains well lubricated, lubrication should be carried out at intervals not exceeding three months during operation.
- All sheaves and guide rollers in contact with the moving rope should be given regular visual checks for surface wear and lubricated to make sure that they run freely. This operation should be carried out at appropriate intervals generally not exceeding three months during operation. For all sheave axles, the factory recommends standard wheel bearing grease. For all sheaves and /or guide rollers, the factory recommends **90 WT** gear oil or similar heavy lubricant applied by any method including pump / spray dispensing, brush, hand and /or swabbing.

Failure to read, understand, and follow these instructions may cause death or serious injury.
Read and understand these instructions before using lift.

SAFETY INSTRUCTIONS



Read operating and safety manuals before using lift. ©

SAFETY INSTRUCTIONS



Proper maintenance and inspection is necessary for safe operation. ©

SAFETY INSTRUCTIONS



Do not operate a damaged lift. ©

The messages and pictographs shown are generic in nature and are meant to generally represent hazards common to all automotive lifts regardless of specific style

Funding for the development and validation of these labels was provided by the Automotive Lift Institute, PO Box 33116 Indianalantic, FL 32903

They are protected by copyright
Set of labels may be obtained from
ALI or its member companies

© 1992 by ALI, Inc

ALI/WL1018

! DANGER

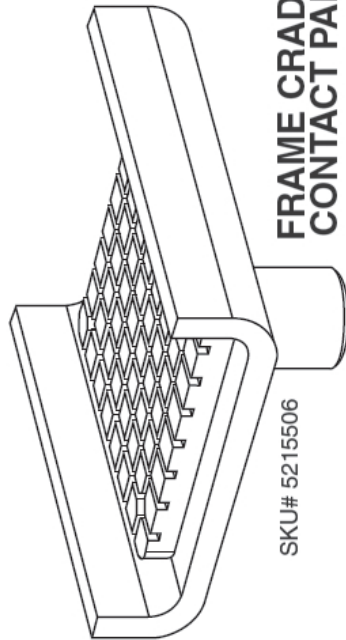

SKU# 5215506

FRAME CRADLE CONTACT PADS

USE PROPER ADAPTERS

Do not attempt to lift trucks or other frame type vehicles with standard flat contact pads. Frame cradle contact pads are recommended for use when lifting trucks, vans, or other frame vehicles. NEVER use lift with missing or damaged rubber pads. ALWAYS REPLACE rubber contact pads when worn or damaged. Contact BendPak or your BendPak dealer for product information.

BendPak, Inc. ®

P/N 5905585

▲ WARNING		▲ WARNING	
	Position vehicle with center of gravity midway between adapters.		Clear area if vehicle is in danger of falling.
▲ WARNING		▲ WARNING	
	Avoid excessive rocking of vehicle while on lift.		Remain clear of lift when raising or lowering vehicle.
▲ WARNING		▲ WARNING	
	Keep feet clear of lift while lowering.		Do not override self-closing lift controls.

The messages and pictographs shown are generic in nature and are meant to generally represent hazards common to all automotive lifts regardless of specific style.
Funding for the development and validation of these labels was provided by the Automotive Lift Institute, PO Box 33116 Indianapolis, FL 32903.
They are protected by copyright. Set of labels may be obtained from ALI or its member companies.
© 1992 by ALI, Inc. ALI/WL101W

▲ CAUTION		▲ CAUTION	
	Lift to be used by trained operator only.		Authorized personnel only in lift area.
▲ CAUTION		▲ CAUTION	
	Use vehicle manufacturer's lift points.		Always use safety stands when removing or installing heavy components.
▲ CAUTION		▲ CAUTION	
	Use height extenders when necessary to ensure good contact.		Auxiliary adapters may reduce load capacity.

The messages and pictographs shown are generic in nature and are meant to generally represent hazards common to all automotive lifts regardless of specific style.
Funding for the development and validation of these labels was provided by the Automotive Lift Institute, PO Box 33116 Indianapolis, FL 32903.
They are protected by copyright. Set of labels may be obtained from ALI or its member companies.
© 1992 by ALI, Inc. ALI/WL101C

Safe Lift Operation

Automotive and truck lifts are critical to the operation and profitability of your business. The safe use of this and other lifts in your shop is critical in preventing employee injuries and damage to customer's vehicles. By operating lifts safely you can insure that your shop is profitable, productive and safe.

Safe operation of automotive lifts requires that only trained employees should be allowed to use the lift.

TRAINING SHOULD INCLUDE, BUT NOT LIMITED TO:

- ◆ Proper positioning of the vehicle on the lift arms. (See manufacturers minimize wheel base loading requirements.)
- ◆ Use of the operating controls.
- ◆ Understanding the lift capacity.
- ◆ Proper use of jack stands or other load supporting devices.
- ◆ Proper use, understanding and visual identification of safety lock devices and their operation.
- ◆ Reviewing the safety rules.
- ◆ Proper housekeeping procedures (lift area should be free of grease, oil, tools, equipment, trash, and other debris).
- ◆ A daily inspection of the lift should be completed prior to its use. Safety devices, operating controls, lift arms and other critical parts should be inspected prior to using the lift.
- ◆ All maintenance and repairs of the lift should be completed by following the manufacturer's requirements. Lift repair parts should meet or exceed OEM specifications. Repairs should only be completed by a qualified lift technician.
- ◆ The vehicle manufacturer's recommendations should be used for spotting and lifting the vehicle.

LIFT OPERATION / SAFETY

- ◆ It is important that you know the load limit. Be careful that you do not overload the lift . If you are unsure what the load limit is, check the data plate found on one of the lift columns or contact the manufacturer.
- ◆ The center of gravity should be followed closely to what the manufacturer recommends.
- ◆ Always make sure you have proper overhead clearance. Additionally, check that attachments, (vehicle signs, campers, antennas, etc.) are not in the way.
- ◆ Be sure that prior to the vehicle being raised, the doors, trunk, and hood are closed securely.
- ◆ Prior to being raised, make sure there is no one standing closer than six feet from the lift.
- ◆ After positioning the vehicle on the lift runways, set the emergency brake, make sure the ignition is off, the doors are closed, overhead obstructions are cleared, and the transmission is in neutral.
- ◆ Double check that the automatic chock devices are in position and then when the lift is raised, observe the chocks.
- ◆ Put pads or adapters in the right position under the contact points that have been recommended.
- ◆ The lift should be raised just until the vehicle's wheels are about one foot off the ground. If contact with the vehicle is uneven or it appears that the vehicle is not sitting secure, carefully lower the lift and readjust.
- ◆ Always consider potential problems that might cause a vehicle to slip, i.e., heavy cargo, undercoating, etc.
- ◆ Pay attention when walking under a vehicle that is up on the hydraulic lift.



- ◆ **DO NOT** leave the controls while the lift is still in motion.
- ◆ **DO NOT** stand directly in front of the vehicle or in the bay when vehicle is being loaded or driven into position.
- ◆ **DO NOT** go near vehicle or attempt to work on the vehicle when being raised or lowered.
- ◆ **REMAIN CLEAR** of lift when raising or lowering vehicle.
- ◆ **DO NOT** rock the vehicle while on the lift or remove any heavy component from vehicle that may cause excessive weight shift.
- ◆ **DO NOT** lower the vehicle until people, materials, and tools are clear
- ◆ **ALWAYS ENSURE** that the safeties are engaged and lowered on to the safeties before any attempt is made to work on or near vehicle.
- ◆ Some vehicle maintenance and repair activities may cause the vehicle to shift. Follow the manufacturer's guidelines when performing these operations. The use of jack stands or alternate lift points may be required when completing some repairs.
- ◆ **READ AND UNDERSTAND** all safety warning procedures before operating lift.
- ◆ **KEEP HANDS AND FEET CLEAR.** Remove hands and feet from any moving parts. Keep feet clear of lift when lowering. Avoid pinch points.
- ◆ **ONLY TRAINED OPERATORS** should operate this lift. All non-trained personnel should be kept away from work area. Never let non-trained personnel come in contact with, or operate lift.
- ◆ **USE LIFT CORRECTLY.** Use lift in the proper manner. Never use lifting adapters other than what is approved by the manufacturer.
- ◆ **DO NOT** override self-closing lift controls.
- ◆ **CLEAR AREA** if vehicle is on danger of falling.
- ◆ **STAY ALERT.** Watch what you are doing. Use common sense. Be aware.
- ◆ **CHECK FOR DAMAGED PARTS.** Check for alignment of moving parts, breakage of parts or any condition that may affect its operation. Do not use lift if any component is broken or damaged.
- ◆ **NEVER** remove safety related components from the lift. Do not use lift if safety related components are damaged or missing.
- ◆ When the lift is being lowered, make sure everyone is standing at least six feet away.
- ◆ Be sure there are no jacks, tools, equipment, left under the lift before lowering.
- ◆ Always lower the vehicle down slowly and smoothly.

LIFT WILL NOT RAISE

POSSIBLE CAUSE

1. Air in oil, (1,2,8,13)
2. Cylinder binding, (9)
3. Cylinder leaks internally, (9)
4. Motor run backward under pressure, (11)
5. Lowering valve leaks, (3,4,6,10,11)
6. Motor runs backwards, (7,14,11)
7. Pump damaged, (10,11)
8. Pump won't prime, (1,8,13,14,3,12,10,11)
9. Relief valve leaks, (10,11)
10. Voltage to motor incorrect, (7,14,11)

REMEDY

INSTRUCTION

- | | |
|--|--|
| 1. Check for proper oil level. | The oil level should be up to the bleed screw in the reservoir with the lift all the way down. |
| 2. Bleed cylinders. | See Installation Manual |
| 3. Flush release valve to get rid of. possible contamination | Hold release handle down and start unit allowing it to run for 15 seconds. |
| 4. Dirty oil. | Replace oil with clean Dexron ATF. |
| 5. Tighten all fasteners. | Tighten fasteners to recommended torques. |
| 6. Check for free movement of release. | If handle does not move freely, replace bracket or handle assembly. |
| 7. Check if motor is wired correctly. | Compare wiring of motor to electrical diagram on drawing. |
| 8. Oil seal damaged or cocked | Replace oil seal around pump shaft. |
| 9. See Installation Manual | Contact BendPak Customer Support. |
| 10. Replace with new part | Replace with new part. |
| 11. Return unit for repair | Return unit for repair. |
| 12. Check pump-mounting bolts | Bolts should be 15 to 18 ft. lbs. |
| 13. Inlet screen clogged | Clean inlet screen or replace. |
| 14. Check wall outlet voltages and wiring | Make sure unit and wall outlet are wired properly. |

LIFT WILL NOT RAISE

POSSIBLE CAUSE

1. Air in oil, (1,2,8,13)
2. Cylinder binding, (9)
3. Cylinder leaks internally, (9)
4. Motor run backward under pressure, (11)
5. Lowering valve leaks, (3,4,6,10,11)
6. Motor runs backwards, (7,14,11)
7. Pump damaged, (10,11)
8. Pump won't prime, (1,8,13,14,3,12,10,11)
9. Relief valve leaks, (10,11)
10. Voltage to motor incorrect, (7,14,11)

REMEDY

1. Check for proper oil level.
2. Bleed cylinders.
3. Flush release valve to get rid of possible contamination
4. Dirty oil.
5. Tighten all fasteners.
6. Check for free movement of release.
7. Check if motor is wired correctly.
8. Oil seal damaged or cocked
9. See Installation Manual
10. Replace with new part
11. Return unit for repair
12. Check pump-mounting bolts
13. Inlet screen clogged
14. Check wall outlet voltages and wiring

INSTRUCTION

- The oil level should be up to the bleed screw in the reservoir with the lift all the way down.
- See Installation Manual
- Hold release handle down and start unit allowing it to run for 15 seconds.
- Replace oil with clean Dexron ATF.
- Tighten fasteners to recommended torques.
- If handle does not move freely, replace bracket or handle assembly.
- Compare wiring of motor to electrical diagram on drawing.
- Replace oil seal around pump shaft.
- Contact BendPak Customer Support.
- Replace with new part.
- Return unit for repair.
- Bolts should be 15 to 18 ft. lbs.
- Clean inlet screen or replace.
- Make sure unit and wall outlet are wired properly.

MOTOR WILL NOT RUN

POSSIBLE CAUSE

1. Fuse blown, (5,2,1,3,4)
2. Limit switch burned out, (1,2,3,4)
3. Microswitch burned out, (1,2,3,4)
4. Motor burned out, (1,2,3,4,6)
5. Voltage to motor incorrect, (2,1,8)

REMEDY

- | REMEDY | INSTRUCTION |
|---|---|
| 1. Check for correct voltage | Compare supply voltage with voltage on motor name tag. Check that the wire is sized correctly. N.E.C. table 310-12 requires AWG 10 for 25 Amps. |
| 2. Check motor is wired correctly | Compare wiring of motor to electrical diagram on drawing. |
| 3. Don't use extension cords | According to N.E.C. : " The size of the conductors... should be such that the voltage drop would not exceed 3% to the farthest outlet for power..." Do not run motor at 115 VAC – damage to the motor will occur. |
| 4. Replace with new part | Replace with new part. |
| 5. Reset circuit breaker/fuse | Reset circuit breaker/fuse. |
| 6. Return unit for repair | Return unit for repair. |
| 7. See Installation Manual | See Installation Manual. |
| 8. Check wall outlet voltage and wiring | Make sure unit and wall outlet is wired properly. Motor must run at 208/230 VAC. |

LIFT LOWERS SLOWLY OR NOT AT ALL

POSSIBLE CAUSE

1. Cylinders binding, (1)
2. Release valve clogged, (5,4,2,3)
3. Pressure fitting too long, (6)

REMEDY

- | REMEDY | INSTRUCTION |
|---|--|
| 1. See Installation Manual | Contact BendPak Customer Support. |
| 2. Replace with new part | Replace with new part. |
| 3. Return for repair | Return for repair. |
| 4. Check oil. | Use clean 10-WT hydraulic oil or Dexron-III automatic transmission fluid only. If ATF is contaminated, replace with clean ATF and clean entire system. |
| 5. Clean release valve | Wash release valve in solvent and blow out with air. |
| 6. Replace fitting with short thread lead | Replace fitting with short thread lead. |

WILL NOT RAISE LOADED LIFT

POSSIBLE CAUSE

1. Air in oil, (1,2,3,4)
2. Cylinder binding, (5)
3. Cylinder leaks internally, (5)
4. Lift overloaded, (6,5)
5. Lowering valve leaks, (7,8,1,5,9)
6. Motor runs backwards, (10,12,9)
7. Pump damaged, (5,9)
8. Pump won't prime, (1,2,3,4,5,11,9)
9. Relief valve leaks, (8,5,9)
10. Voltage to motor incorrect, (10,12,5)

REMEDY

1. Check oil level The oil level should be up to the bleed screw in the reservoir with the lift all the way down.
2. Check/Tighten inlet tubes Replace inlet hose assembly.
3. Oil seal damaged or cocked Replace oil seal and install.
4. Bleed cylinders See Installation Manual.
5. See Installation Manual Contact BendPak Customer Support.
6. Check vehicle weight Compare weight of vehicle to weight limit of the lift.
7. Flush release valve Hold release handle down and start unit allowing it to run for 15 seconds.
8. Replace with new part Replace with new part.
9. Return unit for repair Return unit for repair.
10. Check motor is wired correctly Compare wiring of motor to electrical diagram on power unit drawing.
11. Inlet screen clogged Clean inlet screen or replace.
12. Check wall outlet voltage and wiring Make sure unit and wall outlet is wired properly.

INSTRUCTION

IMPORTANT

If vehicle becomes stranded in the air, follow all operation instructions as shown on pages 27 - 31. If after observing that all mechanical locks are released and the lift still fails move following all standard operating procedures, immediately stop using the lift and contact factory or factory approved service center for further instructions.

LIFT WILL NOT STAY UP

POSSIBLE CAUSE



1. Air in oil, (1,2,3)
2. Check valve leaks, (6)
3. Cylinders leak internally, (7)
4. Lowering valve leaks, (4,5,1,7,6)
5. Leaking fittings, (8)

REMEDY

1. Check oil level The oil level should be up to the bleed screw in the reservoir with the lift all the way down.
2. Oil seal damaged and cocked Replace oil seal around pump shaft.
3. Bleed cylinder Refer to Installation Manual.
4. Flush release valve Hold release handle down and start unit allowing it to run for 15 seconds.
5. Replace with new valve Replace with new valve.
6. Return unit for repair Return unit for repair.
7. See Installation Manual Contact BendPak Customer Support.
8. Check complete hydraulic system for leaks. Tighten all hydraulics fittings and inspect all hoses.

INSTRUCTION

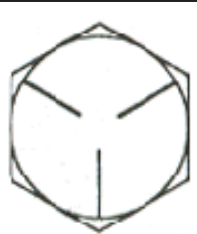
Torque Recommendations

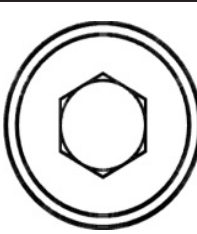
VALUES ARE STATED IN FOOT POUNDS (ft-lb)					
					
		SAE 0-1-2	SAE Grade 5	SAE Grade 8	SOCKET HEAD CAP SCREW
		CLASS 4.8	CLASS 8.8	CLASS 10.9	CLASS 12.9
Bolt Size (SAE)	Bolt Size (Metric)				
1/4-20	M6 x 1.0	6	10	14	13
5/16-18	M8 x 1.25	12	19	29	31.4
3/8-16	M10 x 1.50	20	33	47	62
7/16-14		32	54	78	
1/2-13	M12 x 1.75	47	78	119	108
9/16-12	M14 x 2.00	69	114	169	173
5/8-11	M16 x 2.00	96	154	230	269
3/4-10	M18 x 2.50	155	257	380	372
7/8-9	M22 x 2.50	206	382	600	716
3/4 Anchor Bolts		75 MIN 110 MAX			

INSTALLATION FORM

Customer Name:		Date of Installation:
Company Name:		
Street Address:		
City:	State:	Zip:
Phone:	Fax:	

Pre-Install Agreement

I, (the undersigned) acting as the owner of the business listed above assume responsibility for any permits required, either state or county mandated, related to the installation and/or operation of this equipment. I assume responsibility for the concrete floor and condition thereof, now or later, where the above equipment model(s) are installed. I will assume all liability for losses, damages (including loss of use), expenses, demands, claims, and judgments in connection with or arising out of any personal injury or alleged damage to property, sustained or alleged to have been sustained in connection with, or to have arisen out of the condition and/or drilling of the concrete near or adjacent to the equipment model(s) listed above. If my employee(s) offer assistance of any kind during installation of the above equipment model(s) I hold the manufacturer and installation company harmless of all liability for losses, damages, expenses, claims, and judgments in connection with or arising out of any personal injury or alleged damage to property, sustained or alleged to have been sustained in connection with the installation of the above equipment model(s).

I understand that the lifts above are supplied with concrete fasteners meeting the criteria of the American National Standard "Automotive Lifts - Safety Requirements for Construction, Testing, and Validation" ANSI/ALI ALCTV-1998, and that I will be responsible for all charges related to any special regional structural and/or seismic anchoring requirements specified by any other agencies and/or codes such as the Uniform Building Code (UBC) and/or International Building Code (IBC).

Customer Signature: _____ Print Name: _____ Date: _____

Post-Installation Check-Off

- | | |
|---|---|
| <input type="checkbox"/> Base and Columns Properly Shimmed And Stable | <input type="checkbox"/> Lubrication of Critical Components |
| <input type="checkbox"/> Anchor Bolts Tightened | <input type="checkbox"/> Lift Adapters |
| <input type="checkbox"/> Runways Properly Attached and Secured | <input type="checkbox"/> Check For Overhead Obstructions |
| <input type="checkbox"/> Electric Power Supply Confirmed | <input type="checkbox"/> Runways Level |
| <input type="checkbox"/> Cables / Chains Adjusted Properly | <input type="checkbox"/> All Screws, Bolts, and Pins Secured |
| <input type="checkbox"/> Safety Locks Functioning Properly | <input type="checkbox"/> Surrounding Area and Lift Clean In Appearance |
| <input type="checkbox"/> Check For Hydraulic Leaks | <input type="checkbox"/> Proper Operation, Maintenance and Safety Explained |
| <input type="checkbox"/> Oil Level | <input type="checkbox"/> Operation and Safety Manual(s) Left at Site |

I, (the undersigned) confirm that the above installation procedure(s) were completed. I understand that I will be responsible for maintaining this equipment as outlined in the accompanied **Installation and Operation Manual** and **ANSI/ALI ALOIM Safety Requirements for Operation, Inspection and Maintenance**. I understand that personal injury and/or damage to property can occur if the above equipment model(s) are not maintained or used improperly and take full responsibility for training my employees on proper use and maintenance of this equipment. I hold the manufacturer and installation company harmless of all liability for losses, damages (including loss of use), expenses, demands, claims, and judgments in connection with or related to improper use, improper training, or lack of required maintenance. I understand that the warranty does not cover replacement of parts worn or damaged due to normal use or lack of required maintenance

Customer Signature: _____ Print Name: _____ Date: _____

Installer Signature: _____ Print Name: _____ Date: _____

Installer Company Name: _____

Street Address: _____

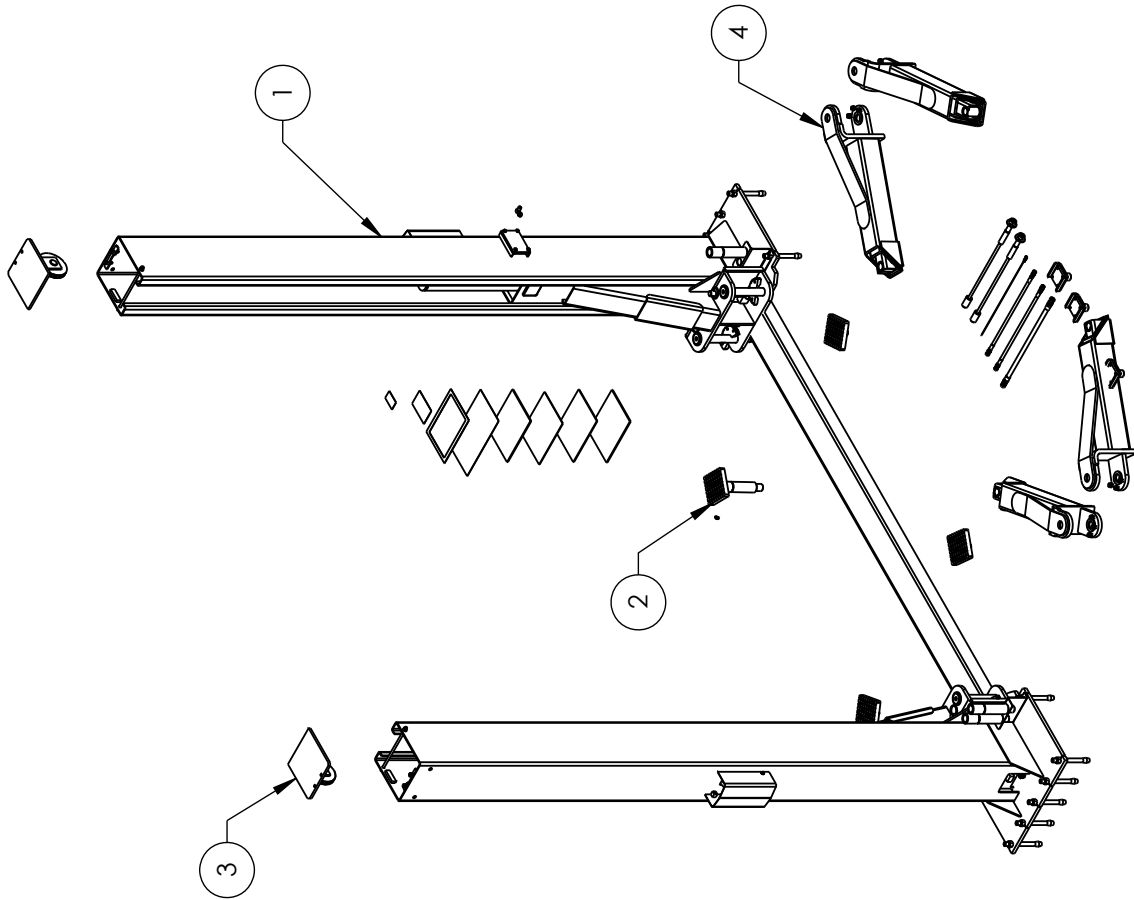

City: _____ State: _____ Zip: _____

Phone: _____ Phone (Other): _____



ITEM NO	PART NUMBER	DESCRIPTION	QTY	REV
1	5245137	XPR-12FD LIFT SUPERSTRUCTURE	1	M
2	5250132	XPR-12FD/XPR-12FD-LWB PARTS BOX	1	M
3	5215376	XPR-12FD TOP EQUALIZER PULLEY PLATE ASSEMBLY	2	F
4	5210149	XPR-12C/FD TRIPLE TELESCOPING ARM ASSEMBLY	4	G

DO NOT SCALE DRAWING		NAME	DATE
DIMENSIONS ARE IN MM		TM	02/12/2010
		CHECKED	MM
			04/01/2013

		THIRD ANGLE PROJECTION 
MATERIAL: ---		TITLE: XPR-12FD RECEIVED LIFT VER C
SIZE: ---		SIZE DWG. NO. 5260142
		REV R
		SCALE: 1:35
		SHEET 1 OF 2

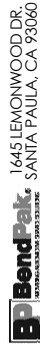

NOTE: UNLESS OTHERWISE SPECIFIED.
 1. SEE SHIPPING INSTRUCTIONS FOR FINAL PACKAGING

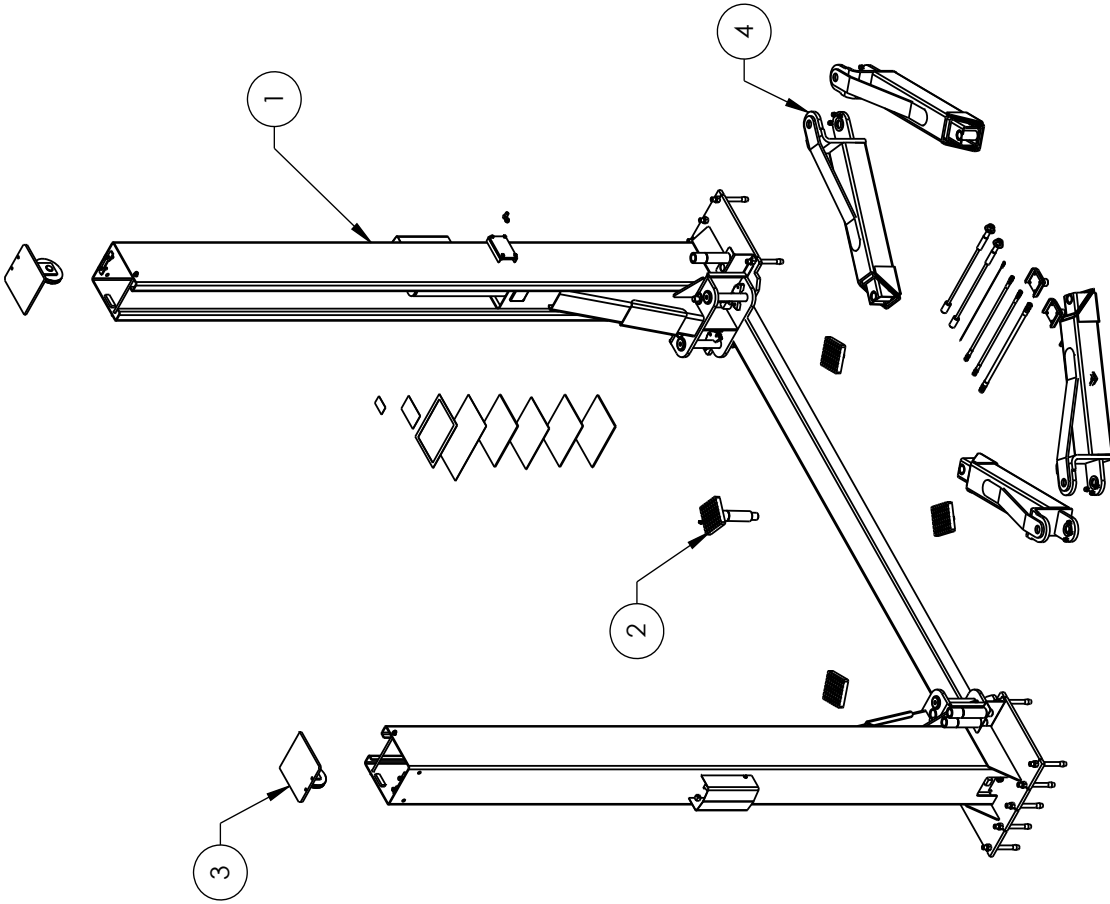

ITEM NO	PART NUMBER	DESCRIPTION	QTY	REV
1	5245137	XPR-12FD LIFT SUPERSTRUCTURE	1	M
2	5250132	XPR-12FD/XPR-12FD-LWB PARIS BOX	1	M
3	5215376	XPR-12FD TOP EQUALIZER PULLEY PLATE ASSEMBLY	2	F
4	5215219	XPR-12-LWB TRIPLE TELESCOPING ARM	4	F

DO NOT SCALE DRAWING		NAME	DATE
DIMENSIONS ARE IN MM		TM	02/15/2010
 THIRD ANGLE PROJECTION		CHECKED	MM
		MM	04/01/2013

		BendPak 1645 LEMONWOOD DR. SANTA PAULA, CA 93060	
MATERIAL: ---		TITLE: XPR-12FD-LWB RECEIVED LIFT VER C	
SIZE: ---		SIZE DWG. NO. A 5260144	
		REV R	
		SCALE: 1:35	
		SHEET 1 OF 2	

NOTE: UNLESS OTHERWISE SPECIFIED.
 1. SEE SHIPPING INSTRUCTIONS FOR FINAL PACKAGING

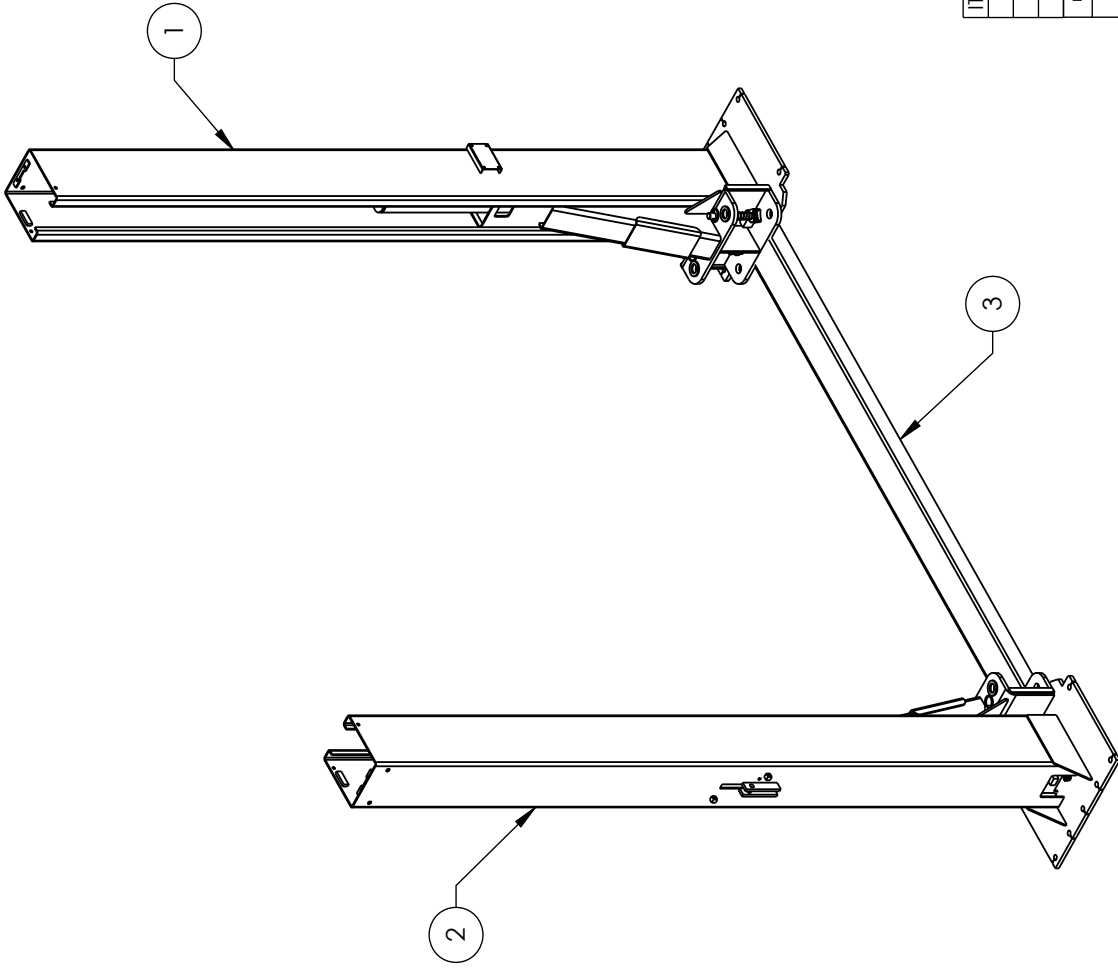

ITEM NO	PART NUMBER	DESCRIPTION	QTY	REV
1	5215356	XPR-12FD POWER SIDE POST ASSEMBLY	1	M
2	5215233	XPR-12FD OFF SIDE POST ASSEMBLY	1	L
3	5210047	XPR-12FD GROUND PLATE	1	B

DO NOT SCALE DRAWING		NAME	DATE
DIMENSIONS ARE IN MM		TM	02/12/2010
		CHECKED	MM
		02/14/2013	

THIRD ANGLE PROJECTION		TITLE:
		XPR-12FD LIFT SUPERSTRUCTURE
MATERIAL:	---	SIZE DWG. NO.
SIZE:	---	A
<small>PROPRIETARY AND CONFIDENTIAL THE INFORMATION CONTAINED HEREIN IS THE SOLE PROPERTY OF BENDPAK INC. ANY REPRODUCTION IN PART OR AS A WHOLE WITHOUT PERMISSION OF BENDPAK INC. IS PROHIBITED.</small>		REV
		M

NEXT ASSEMBLY		SCALE: 1:30
5260142		
5260144		

**NOTE: UNLESS OTHERWISE SPECIFIED,
SEE SHIPPING INSTRUCTIONS FOR FINAL PACKAGING**

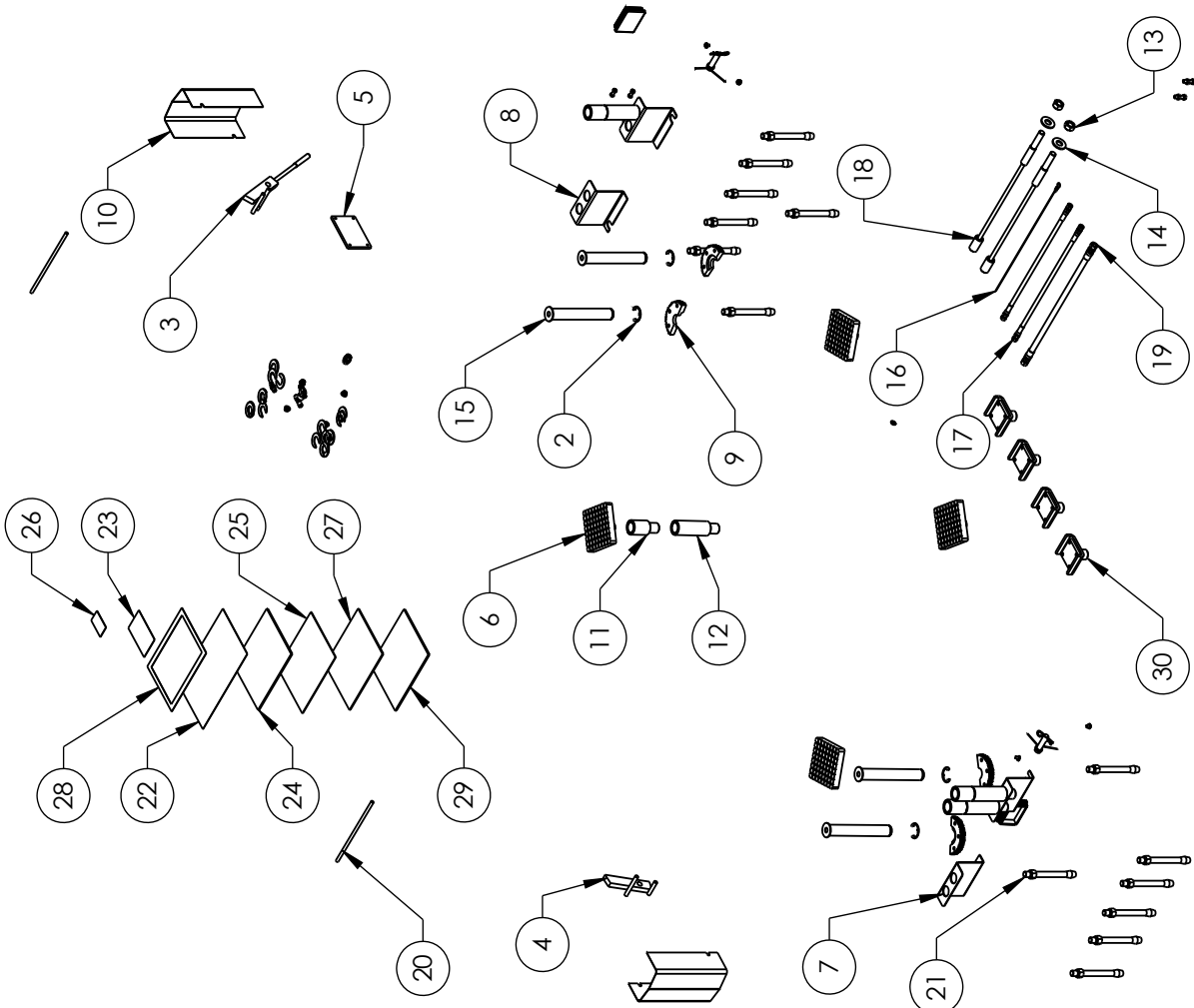

NOTE: UNLESS OTHERWISE SPECIFIED.

1. INSERT PARTS BAG INTO PARTS BOX FOR SHIPMENT
2. SEE SHIPPING INSTRUCTIONS FOR FINAL PACKAGING
3. THREAD 5535358 ONTO CABLES WITH 5545342 FOR SHIPMENT

ITEM NO.	PART NUMBER	DESCRIPTION	QTY	REV
1	5174114	XPR-9D/12FD PARTS BAG	1	E
2	5540129	RING Ø38mm OD	4	-
3	5210007	XPR POWER SIDE SAFETY ASSEMBLY	1	D
4	5210010	XPR OFF SIDE SAFETY WELDMENT	1	B
5	5715003	POWER UNIT VIBRATION DAMPENER	1	B
6	5215250	XPR-12/15/18 SQUARE SLIP ON LIFT PAD ASSEMBLY	4	C
7	5730670	XPR-12/15/18C POST ASSEMBLY LIFT HEAD FOOT R.H.	2	B
8	5730669	XPR-12C/12FD/15/18C POST ASSEMBLY LIFT HEAD FOOT GUARD L.H.	2	C
9	5736605	XPR-12 BOLT ON ARM RESTRAINT GEAR	4	A
10	5210009	XPR-71R/71RFD/9D/10/12/12FD/15/18C OFF SIDE SAFETY COVER	2	C
11	5746390	GP/XPR/RJ/MD-6XP SHORT LIFT PAD EXTENSION (113mm I.G.)	4	B
12	5746395	GP/XPR/RJ LONG LIFT PAD EXTENSION (182mm I.G.)	4	B
13	5535011	NUT M22 x 2.5 NL	2	-
14	5545345	WASHER M22 x 50mm FLA	2	B
15	5505346	XPR-12C/FD LIFT HEAD PIN WELDMENT	4	A
16	5595124	XPR-12-FD Ø2.4 x 7400 SAFETY CABLE	1	B
17	5570118	XPR-12FD HYDRAULIC HOSE ASSEMBLY Ø6.35 x 1562mm DS	2	B
18	5595070	XPR-12FD CABLE ASSY Ø12 x 10800mm	2	B
19	5570126	XPR-12FD HYDRAULIC HOSE ASSY Ø10 x 3150mm DS	2	B
20	5746166	DOUBLE THREADED ROD M10 x 1.5 x 295	14	-
21	5530308	AB 3/4" x 7"	14	-
22	5900109	CAUTION LABEL ALI/M/L 101C	1	-
23	5900151	BENDPAK #90 WARRANTY CARD	1	-
24	5900280	ALI/FP FRAME ENGAGING LIFTS GUIDE	1	-
25	5900152	ALIGN OIM OPERATION INSPECTION & MAINTENANCE	1	-
26	5900153	ALL SAFETY INSTRUCTIONS STICKER	1	-
27	5900147	SAFETY MANUAL ALI / SM 93-1	1	-
28	5905151	SAFETY TIPS CARD ALI-ST-90	1	-
29	5900042	XPR-9FD/9FDX/12FD INSTALLATION MANUAL	1	-
30	5215506	CRADLE LIFT PAD ADAPTER ASSEMBLY	4	C

DO NOT SCALE DRAWING
DIMENSIONS ARE IN MM

MATERIAL: ---
SITE: ---

THIRD ANGLE PROJECTION

DATE: 02/12/2010
DRAWN: TM
CHECKED: MM

BendPak 1645 LEMONWOOD DR.
SANTA PAULA, CA 93060

TITLE: XPR-12FD/XPR-12FD-LWB PARTS BOX

SCALE: 1:25

REV: M

DWG. NO.: 5250132

SHEET 1 OF 1

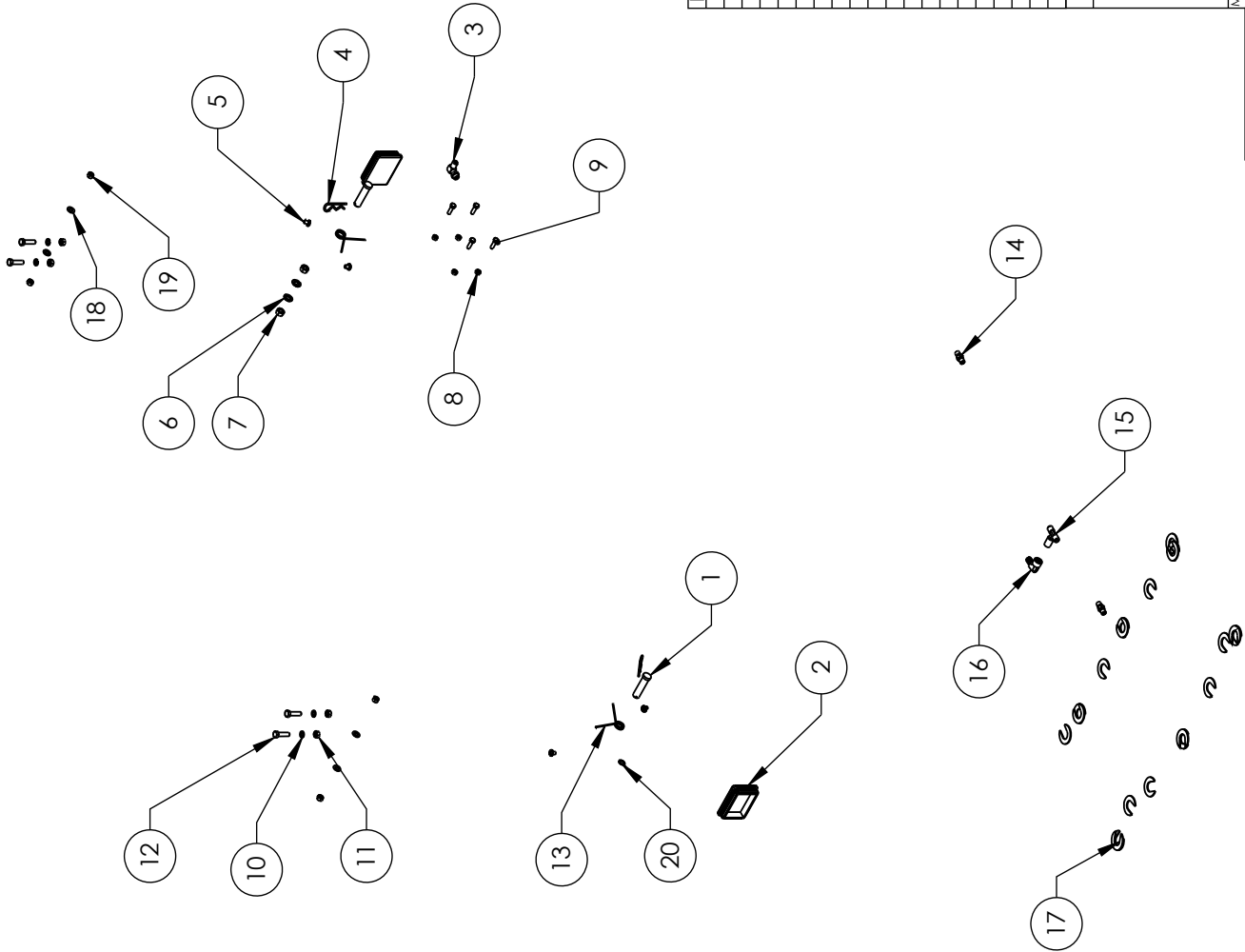

ITEM NO	PART NUMBER	DESCRIPTION	QTY	REV
1	5505113	GP-7/PL-6000/XPR SERIES SAFETY CLEVIS PIN	2	E
2	5715196	GP/XPR PLASTIC COVER BLOCK 105 x 80	2	B
3	5550183	FIG ELB -06 JIC -06L ORB	1	-
4	5505350	MODEL# 211 HAIR PIN/LARGE	2	-
5	5530314	PHPS M8 x 1.25 x 10	4	-
6	5545347	WASHER M12 FLAT WASHER	2	-
7	5535354	NUT M12 x 1.75	2	-
8	5535001	NUT M8 x 1.25 NL	4	-
9	5530010	HHB M8 x 1.25 x 25	4	-
10	5545251	WASHER M10 x 18mm SL	4	-
11	5535998	NUT M10 x 1.5	4	-
12	5530760	HEX HEAD BOLT M10x1.25x35	4	-
13	5540001	2.5 WIRE DIA. Ø25.5x150 LG.	2	-
14	5550147	FIG NPL -04 JIC -04 NPT	2	-
15	5550178	FIG TEE -04 JIC -04 JIC -06 NPT	1	-
16	5550109	FIG ELB -06 JIC x -06 F NPT	1	-
17	5545535	C WASHER SHIM FOR LIFTS	20	-
18	5545341	WASHER M10 x Ø20 FLAT	4	-
19	5535013	NUT M10 x 1.5 NL	4	-
20	5505031	ROTOR CLIP 1/2 INM SS	1	-

DO NOT SCALE DRAWING

DIMENSIONS ARE IN MM

SMILEY FACE

MATERIAL: ---

SIZE: ---

NEXT ASSEMBLY: ---

5750137

5750256

5750320

DRAWN: TM 02/10/2010

CHECKED: MT 03/07/2012

THIRD ANGLE PROJECTION

SMILEY FACE

PROPRIETARY AND CONFIDENTIAL
THE INFORMATION CONTAINED IN THIS DRAWING IS THE SOLE PROPERTY OF BENDPAK INC. ALL RIGHTS RESERVED. NO REPRODUCTION OR TRANSMISSION IS PERMITTED WITHOUT THE WRITTEN PERMISSION OF BENDPAK INC.

TITLE: XPR-9D/12FD PARTS BAG

SIZE: A

DWG. NO.: 5174114

REV: E

SCALE: 1:18

SHEET 1 OF 1

BendPak
1645 LEMONWOOD DR.
SANTA PAULA, CA 93060

**NOTE: UNLESS OTHERWISE SPECIFIED,
1. SEE SHIPPING INSTRUCTIONS FOR FINAL PACKAGING**

CE 2010 CERTIFICATE OF COMPLIANCE

Company: BendPak Inc.
1645 Lemonwood Dr.
Santa Paula, CA 93060

Report No. Q3 11 10 1TYU233

Summary

Test Model(s): XPR-12FD, XPR12-FD-LWB
Serial Number(s): As Listed
Description: Two-Post Hydraulic Lift
Date of Compliance Testing: 08/13/2011

After careful evaluation and testing of the above listed equipment model(s), all areas analyzed met or exceeded the below mentioned standard(s) for safe operation. The products identified above comply with the principal elements of the safety objectives of the Machinery Directive, Low Voltage Equipment Directive, and Electromagnetic Compatibility Directive and the manufacturer has applied the following standards.

Specific Referenced Standard(s) For Meeting Compliance Criteria:

EN1493:2010	Vehicle Lifts.
2006/42/EC	Machinery Directive
2006/95/EC	Low Voltage Directive
2004/108/EC	Electromagnetic Compatibility Directive
EN 60204-1:2006	Safety of machinery - Electrical equipment of machines - Part 1: General Requiriejments
EN 12100-1:2007	Safety of machinery - Basic concepts, general principles for design.

Other applicable standards partial or complete include, but not limited to; ANSI/ALI ALCTV-2011 Automotive Lifts - Safety Requirements for Construction, Testing, and Validation, CAN/CSA C22.2, ANSI/UL 201 American National Standard for Safety for Garage Equipment, Australian/New Zealand Standard AS/NZS 1418.9:1996, AWS D1.1 Structural Welding Code - Steel, ASTM A36/A36M-05 Standard Specification for Carbon Structural Steel, ASTM A618/A618M Standard Specification for Hot-Formed Welded and Seamless High-Strength Low-Alloy Structural Tubing, NF (CFR Reference) Standard Specification for Hot-Formed Welded and Seamless Carbon Steel Structural Tubing and SAE AMS 5080J Steel, Bars, Forgings, and Tubing, 0.31 0.38C (SAE 1035)



I hereby declare that the equipment named above has been designed to comply with the relevant sections of the above referenced specifications. The unit complies with all applicable Essential Requirements of the Directives.



[Signature]
Director, Standards Body

This page intentionally left blank.

This page intentionally left blank.



The best automotive service equipment on the planet.

**For Parts Or Service
Contact:**

**BendPak Inc. / Ranger Products
1645 Lemonwood Dr.
Santa Paula, CA. 93060**

**Tel: 1-805-933-9970
Toll Free: 1-800-253-2363
Fax: 1-805-933-9160**

www.bendpak.com

p/n 5900046

