



IMPORTANT SAFETY INSTRUCTIONS SAVE THESE INSTRUCTIONS

PLEASE READ THE ENTIRE CONTENTS OF THIS MANUAL PRIOR TO INSTALLATION AND OPERATION. BY PROCEEDING WITH LIFT INSTALLATION AND OPERATION YOU AGREE THAT YOU FULLY UNDERSTAND AND COMPREHEND THE FULL CONTENTS OF THIS MANUAL. FORWARD THIS MANUAL TO ALL OPERATORS. FAILURE TO OPERATE THIS EQUIPMENT AS DIRECTED MAY CAUSE INJURY OR DEATH.

MAN REV G 03-21-14
P/N 5900050

INSTALLATION AND OPERATION MANUAL

12,000 POUND CAPACITY
SURFACE MOUNTED
FULL-RISE SCISSOR LIFTS

MODELS:
XR-12000
XR-12000A

VERSION B
VERSION B

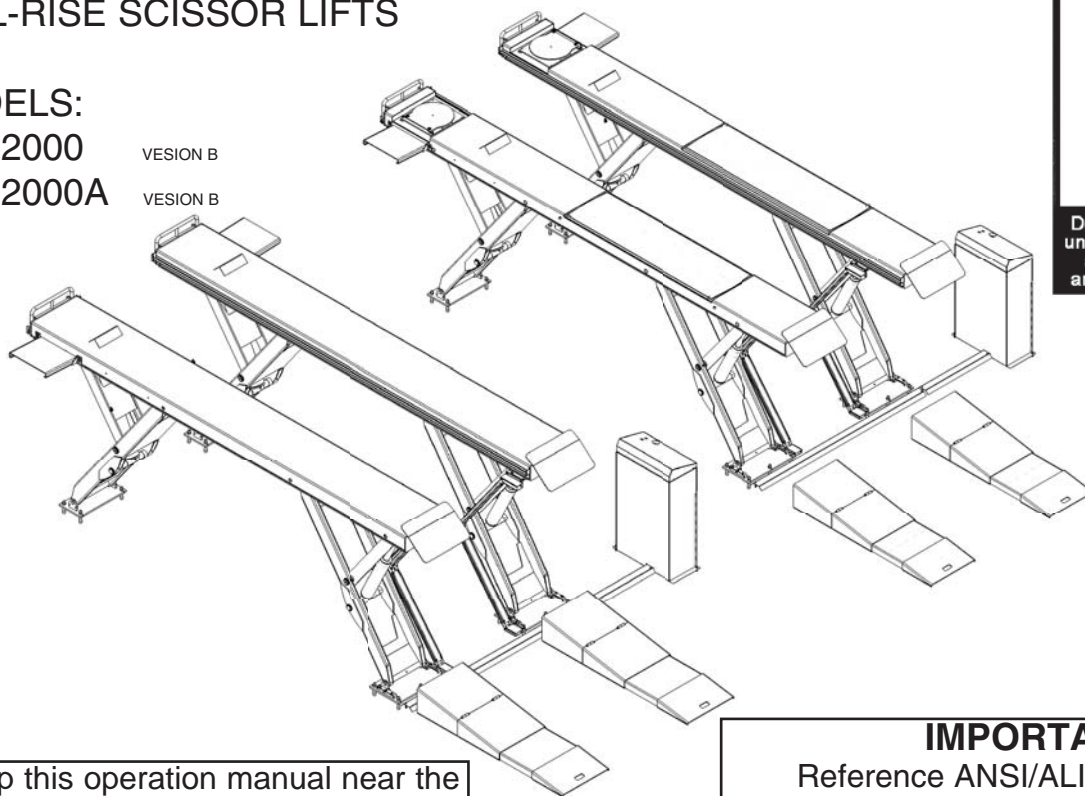

READ FIRST



Do not operate this machine until you read and understand all the dangers, warnings and cautions in this manual.

Keep this operation manual near the machine at all times. Make sure that ALL USERS read this manual.

IMPORTANT

Reference ANSI/ALI ALIS, Safety Requirements for Installation and Service of Automotive Lifts before installing lift.

RECEIVING

The shipment should be thoroughly inspected as soon as it is received. The signed Bill of Lading is acknowledgement by the shipping carrier as receipt of this product as listed in your invoice as being in a good condition of shipment. If any of these goods listed on this Bill of Lading are missing or damaged, do not accept goods until the shipping carrier makes a notation on the freight bill of the missing or damaged goods. Do this for your own protection.

BE SAFE

Your new lift was designed and built with safety in mind. However, your overall safety can be increased with proper training and thoughtful operation on the part of the operator. DO NOT operate or repair this equipment without reading this manual and the important safety instructions shown inside. Keep this operation manual near the lift at all times. Make sure that ALL USERS read and understand this manual.



1645 Lemonwood Dr.
Santa Paula, CA. 93060, USA
Toll Free 1-800-253-2363
Tel: 1-805-933-9970
Fax: 1-805-933-9160
wwwbendpak.com

12,000 POUND CAPACITY SURFACE MOUNTED FULL-RISE SCISSOR LIFTS

This instruction manual has been prepared specifically for you. Your new lift is the product of over 40 years of continuing research, testing and development; it is the most technically advanced lift on the market today.

READ THIS ENTIRE MANUAL BEFORE INSTALLATION & OPERATION BEGINS.

RECORD HERE THE LIFT AND POWER UNIT INFORMATION WHICH IS LOCATED ON THE SERIAL NUMBER DATA PLATES ON THE LIFT AND ON THE POWER UNIT

Power Unit Model # _____
Power Unit Date Of Mfg. _____
Power Unit Serial # _____
Max Operating Pressure 1,900 PSI

MODEL NO.	_____	SERIAL NO.	_____
VOLTAGE	_____	DATE OF MFG.	_____
LIFT CAP.	_____	POWER UNIT	_____

DANGER!
Disconnect Power
Before Servicing.

CE PCT TUV SUD SP G

BP BendPak
PROVIDING AUTOMOTIVE SERVICE SOLUTIONS

1645 Lemonwood Drive
Santa Paula, CA 93060
www.bendpak.com

ENGINEERED BY BENDPAK USA • MADE IN CHINA

This information will be required when calling for parts or warranty issues.
Only replace parts with BendPak approved parts.

PRODUCT WARRANTY

Our comprehensive product warranty means more than a commitment to you; it's also a commitment to the value of your new BendPak lift. For full warranty details and to register your new lift contact your nearest BendPak dealer or visit <http://www.bendpak.com/support/warranty/>

NOTE:

Every effort has been taken to ensure complete and accurate instructions have been included in this manual, however, possible product updates, revisions and or changes may have occurred since this printing. BendPak / Ranger reserves the right to change specifications without incurring any obligation for equipment previously or subsequently sold. Not responsible for typographical errors.

IMPORTANT NOTICE

Do not attempt to install this lift if you have never been trained on basic automotive lift installation procedures. Never attempt to lift components without proper lifting tools such as a forklift or cranes. Stay clear of any moving parts that can fall and cause injury. These instructions must be followed to ensure proper installation and operation of your lift. Failure to comply with these instructions can result in serious bodily harm and void product warranty. Manufacturer will assume no liability for loss or damage of any kind, expressed or implied resulting from improper installation or use of this product.

PLEASE READ ENTIRE MANUAL PRIOR TO INSTALLATION.

DEFINITIONS OF HAZARD LEVELS

Identify the hazard levels used in this manual with the following definitions and signal words:



DANGER !

Watch for this symbol as it means: Immediate hazards which will result in severe personal injury or death.



WARNING !

Watch for this symbol as it means: Hazards or unsafe practices which could result in severe personal injury or death.



CAUTION !

Watch for this symbol as it means: Hazards or unsafe practices which may result in minor personal injury, product or property damage.

OWNER'S RESPONSIBILITY

To maintain the lift and user safety, the responsibility of the owner is to read and follow these instructions:

- ◆ Follow all installation and operation instructions.
- ◆ Make sure installation conforms to all applicable Local, State, and Federal Codes, Rules, and Regulations; such as State and Federal OSHA Regulations and Electrical Codes.
- ◆ Carefully check the lift for correct initial function.
- ◆ Read and follow the safety instructions. Keep them readily available for machine operators.
- ◆ Make certain all operators are properly trained, know how to safely and correctly operate the unit, and are properly supervised.
- ◆ Allow unit operation only with all parts in place and operating safely.
- ◆ Carefully inspect the unit on a regular basis and perform all maintenance as required.
- ◆ Service and maintain the unit only with authorized or approved replacement parts.
- ◆ Keep all instructions permanently with the unit and all decals on the unit clean and visible.

BEFORE YOU BEGIN

NOTIFY THE CARRIER AT ONCE if any hidden loss or damage is discovered after receipt and request the carrier to make an inspection. If the carrier will not do so, prepare a signed statement to the effect that you have notified the carrier (on a specific date) and that the carrier has failed to comply with your request.

IT IS DIFFICULT TO COLLECT FOR LOSS OR DAMAGE AFTER YOU HAVE GIVEN THE CARRIER A CLEAR RECEIPT. Support claim with copies of the bill of lading, freight bill, invoice, and photographs, if available. BendPak's willingness to assist in helping you process your claim does not make BendPak responsible for collection of claims or replacement of lost or damaged materials.

CLEARANCES

XR-12000

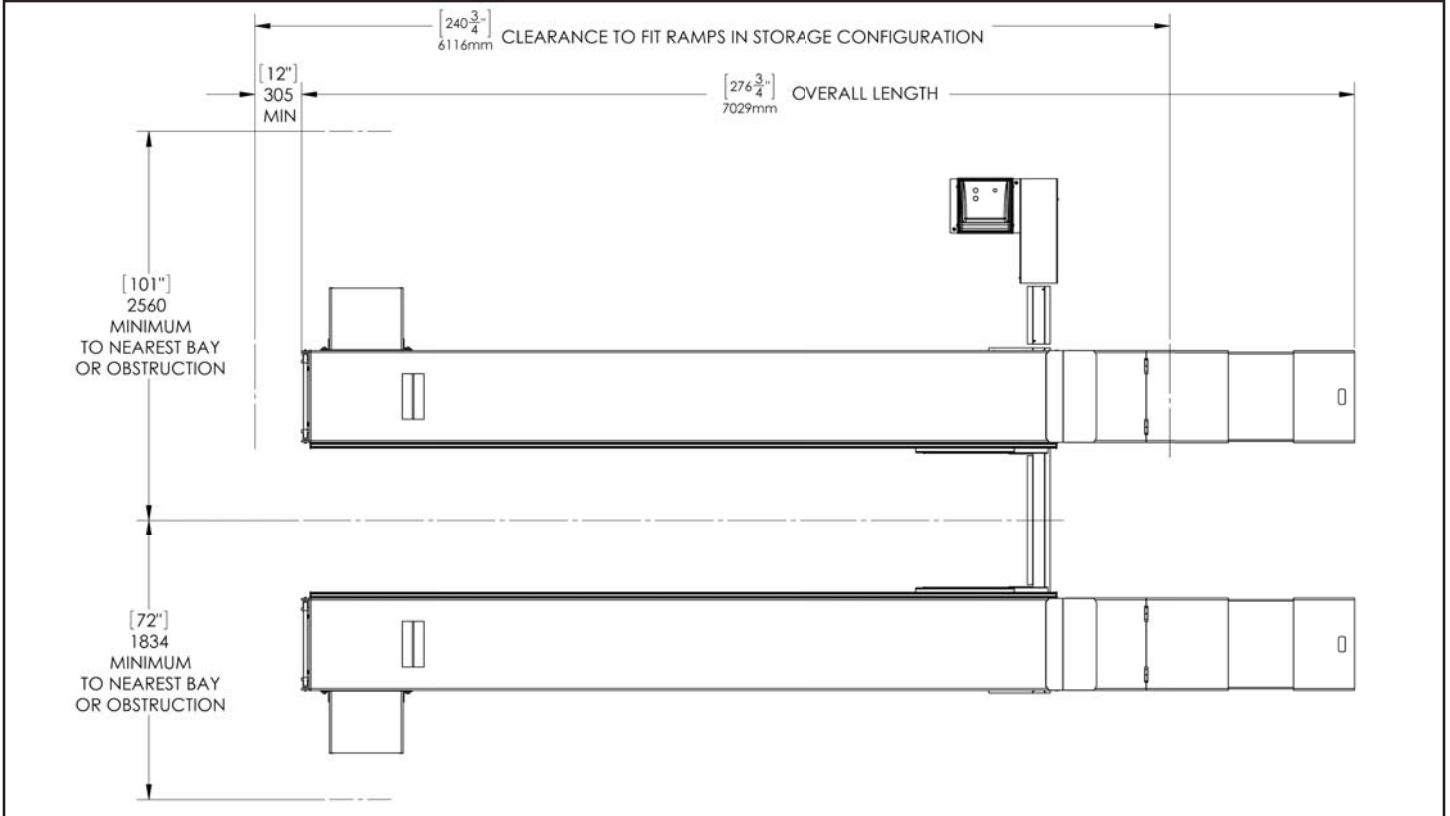

LIFT HEIGHT CLEARANCE NOTE: There must be a 1" MIN distance from top of the loaded vehicle to the nearest obstruction when the lift is in a raised position.

XR-12000A

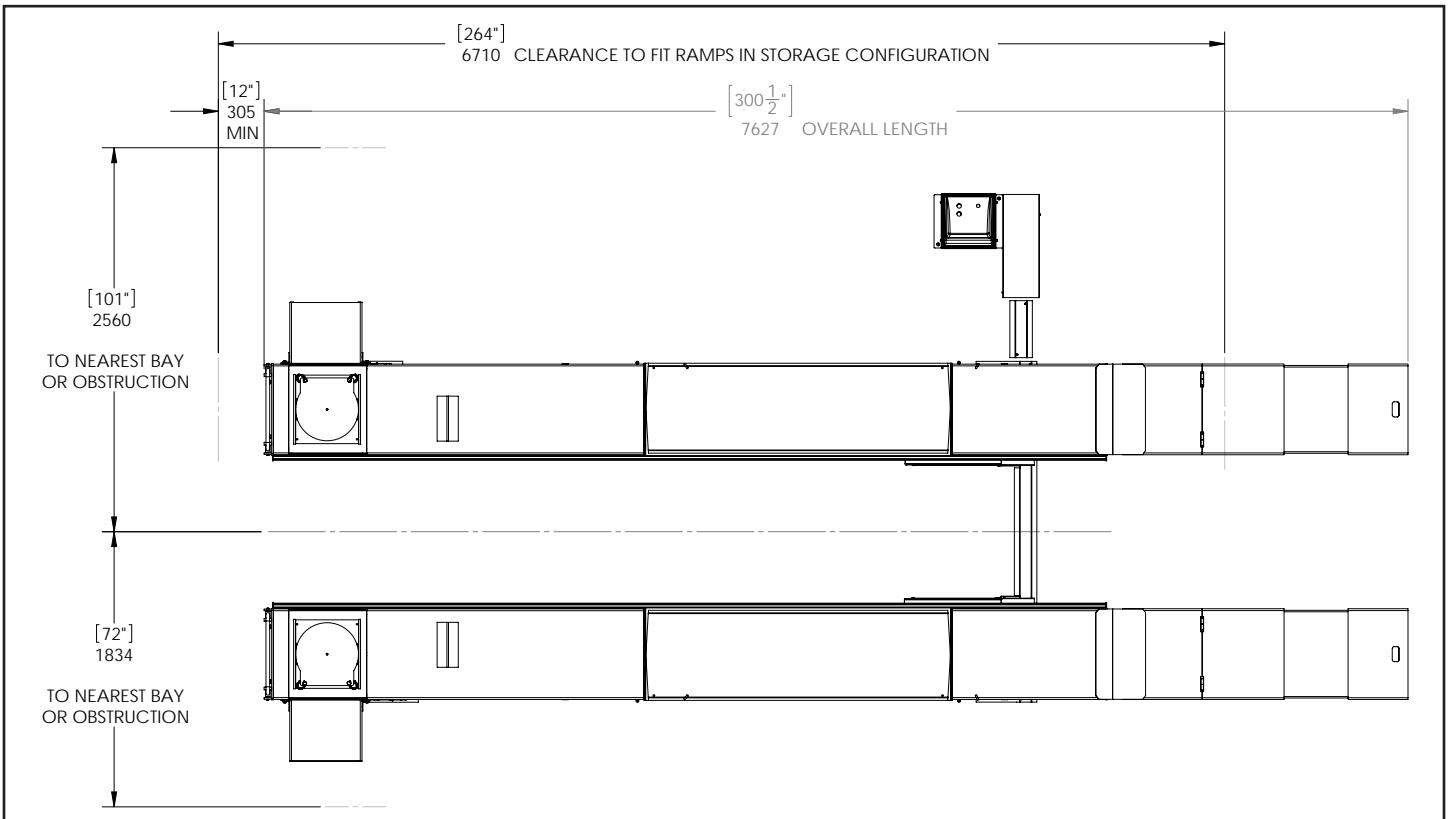

LIFT HEIGHT CLEARANCE NOTE: There must be a 1" MIN distance from top of the loaded vehicle to nearest obstruction when the lift is in a raised position.

TABLE OF CONTENTS

Contents	Page No.
Warranty / Serial Number Information	2
Definitions of Hazard Levels	3
Owner's Responsibility	3
Before You Begin	3
Clearances	4
Installer/Operator Agreement/ Protective Equipment	6
Introduction	7
Safety / Warning Instructions	7
Tools Required	8
Step 1 / Selecting Site	8
Step 2 / Floor Requirements	8
Concrete Specifications	8
Assembly View / Description of Parts	9
Floor Plan / General Specifications	10
Step 3 / Site Layout	11
Step 4 / Aligning the Ramp Assemblies	12
Step 5 / Power Unit Console Installation	12-13
Step 6 / Hydraulic Hose Connection	13
Step 7 / Safety Air Line Connection	13-14
Step 8 / Power Unit Electrical Connection	14, 17-18
Hose Connection/Air Line Routing/Wiring Diagrams.	15-17
Step 9 / Anchoring the Ramps	19
Step 10 / Installing Approach Ramps	19-20
Step 11 / Installing Accessories	20-21
Step 12 / Final Assembly	21
Step 13 / Safety Ladder Bolt Adjustment	21
Step 14 / Hydraulic Air Bleeding and Leveling	22-25
Step 15 / Operation	26
Step 16 / Turnplate Pocket Adjustment	26-27
Step 17 / Work Step Installation	27
Step 18 / Hose Cover Installation	27
Step 19 / Operation Instructions	28
Operation / Maintenance	28-32
Troubleshooting Guide	33-36
Grease Port / Lubrication Locations	37
Maintenance Records	38-40
Installation Form	41
Part Number Lists	42-46

**INSTALLER / OPERATOR
PLEASE READ AND FULLY
UNDERSTAND. BY PROCEEDING
YOU AGREE TO THE FOLLOWING.**

- ◆ I have visually inspected the site where the lift is to be installed and verified the concrete to be in good condition and free of cracks or other defects. I understand that installing a lift on cracked or defective concrete could cause lift failure resulting in personal injury or death.
- ◆ I understand that a level floor is required for proper installation and level lifting.
- ◆ I understand that I am responsible if my floor is of questionable slope and that I will be responsible for all charges related to pouring a new level concrete slab if required and any charges.
- ◆ I understand that BendPak lifts are supplied with concrete fasteners meeting the criteria of the American National Standard "Automotive Lifts - Safety Requirements for Construction, Testing, and Validation" ANSI/ALI ALCTV-2006, and that I will be responsible for all charges related to any special, regional, structural, and/or seismic anchoring requirements specified by any other agencies and/or codes such as the Uniform Building Code (UBC) and/or International Building Code (IBC).
- ◆ I will assume full responsibility for the concrete floor and condition thereof, now or later, where the above equipment model is to be installed. Failure to follow Danger, Warning, and Caution instructions may lead to serious personal injury or death to operator or bystander or damage to property.
- ◆ I understand that BendPak lifts are designed to be installed in indoor locations only. Failure to follow installation instructions may lead to serious personal injury or death to operator or bystander or damage to property or lift.



CAUTION

The safe operating temperature range for this product is 41° F. - 104 °F.



THIS SYMBOL POINTS OUT IMPORTANT SAFETY INSTRUCTIONS WHICH IF NOT FOLLOWED COULD ENDANGER THE PERSONAL SAFETY AND/OR PROPERTY OR YOURSELF AND OTHERS AND CAN CAUSE PERSONAL INJURY OR DEATH. READ AND FOLLOW ALL INSTRUCTIONS IN THIS MANUAL BEFORE ATTEMPTING TO OPERATE THIS MACHINE.



Failure to follow Danger, Warning, and Caution instructions may lead to serious personal injury or death to operator or bystander or damage to property.



Please read the entire manual prior to installation. Do not operate this machine until you have read and have understood all of the Danger, Warning and Caution alerts in this manual. For additional copies or further information, contact:

BendPak Inc.

1645 Lemonwood Dr.
Santa Paula, CA. 93060
1-805-933-9970
www.bendpak.com

**INSTALLER / OPERATOR
PROTECTIVE EQUIPMENT**

Personal protective equipment helps makes installation and operation safer, however, it does not take the place of safe operating practices. Always wear durable work clothing during any installation and/or service activity. Shop aprons or shop coats may also be worn, however loose-fitting clothing should be avoided.

Tight-fitting leather gloves are recommended to protect the technician's hands when handling parts. Sturdy leather steel-toe work shoes and oil resistant soles should be used by all service personnel to help prevent injury during typical installation and operation activities.

Eye protection is essential during installation and operation activities. Safety glasses with side shields, goggles, or face shields are acceptable. Everyday eyeglasses only have impact resistant lenses, they are not safety glasses. Back belts provide support during lifting activities and are also helpful in providing worker protection. Consideration should also be given to the use of hearing protection if service activity is performed in an enclosed area, or if noise levels are high.



INTRODUCTION

1. Carefully remove the crating and packing materials. **CAUTION!** Be careful when cutting steel banding material as items may become loose and fall causing personal harm or injury.

2. Check the voltage, phase and proper amperage requirements for the motor shown on the motor plate. Wiring should be performed by a certified electrician only.

IMPORTANT SAFETY INSTRUCTIONS !

Read these safety instructions entirely!

IMPORTANT NOTICE !

Do not attempt to install this lift if you have never been trained on basic automotive lift installation procedures.

Never attempt to lift components without proper lifting tools such as forklift or cranes.

Stay clear of any moving parts that can fall and cause injury.

1. **READ AND UNDERSTAND** all safety warning procedures before operating lift.

2. **KEEP HANDS AND FEET CLEAR.** Remove hands and feet from any moving parts. Keep feet clear of lift when lowering. Avoid pinch points.

3. **KEEP WORK AREA CLEAN.** Cluttered work areas invite injuries.

4. Consider work area environment. Do not expose equipment to rain. **DO NOT** use in damp or wet locations. Keep area well lighted.

5. **ONLY TRAINED OPERATORS** should operate this lift. All non-trained personnel should be kept away from work area. Never let non-trained personnel come in contact with, or operate lift.

6. **USE LIFT CORRECTLY.** Use lift in the proper manner. Never use lifting adapters other than what is approved by the manufacturer.

7. **DO NOT** override self-closing lift controls.

8. **REMAIN CLEAR** of lift when raising or lowering vehicle.

9. **CLEAR AREA** if vehicle is in danger of falling.

10. **ALWAYS ENSURE** that the safeties are engaged before any attempt is made to work on or near vehicle.

11. **DRESS PROPERLY.** Non-skid steel-toe footwear is recommended when operating lift.

12. **GUARD AGAINST ELECTRIC SHOCK.** This lift must be grounded while in use to protect the operator from electric shock. Never connect the green power cord wire to a live terminal. This is for ground only.



13. **DANGER!** The power unit used on this lift contains high voltage. Disconnect power at the receptacle before performing any electrical repairs. Secure plug so that it cannot be accidentally plugged in during service.



14. **WARNING! RISK OF EXPLOSION.** This equipment has internal arcing or sparking parts which should not be exposed to flammable vapors. This machine should not be located in a recessed area or below floor level.



15. **MAINTAIN WITH CARE.** Keep lift clean for better and safer performance. Follow manual for proper lubrication and maintenance instructions. Keep control handles and/or buttons dry, clean and free from grease and oil.

16. **STAY ALERT.** Watch what you are doing. Use common sense. Be aware.

17. **CHECK FOR DAMAGED PARTS.** Check for alignment of moving parts, breakage of parts or any condition that may affect its operation. Do not use lift if any component is broken or damaged.

18. **NEVER** remove safety related components from the lift. Do not use lift if safety related components are damaged or missing.

19. Keep hair, loose clothing, fingers, and all parts of body away from moving parts

20. Use only as described in this manual. Use only manufacturer's recommended attachments

21. **ALWAYS WEAR SAFETY GLASSES.** Everyday eye-glasses only have impact resistant lenses, they are not safety glasses

SAVE THESE INSTRUCTIONS

TOOLS REQUIRED

- ◆ Rotary Hammer Drill or Similar
- ◆ 3/4" Masonry Bit
- ◆ Hammer
- ◆ 4 Foot Level
- ◆ Open-End Wrench Set: SAE/Metric
- ◆ Socket And Ratchet Set: SAE/Metric
- ◆ Hex-Key / Allen Wrench Set
- ◆ Large Crescent Wrench
- ◆ Large Pipe Wrench
- ◆ Crow Bar
- ◆ Chalk Line
- ◆ Medium Flat Screwdriver
- ◆ Tape Measure: 25 Foot Minimum
- ◆ Needle Nose Pliers

IMPORTANT NOTICE

THESE INSTRUCTIONS MUST BE FOLLOWED TO INSURE PROPER INSTALLATION AND OPERATION OF YOUR LIFT. FAILURE TO COMPLY WITH THESE INSTRUCTIONS CAN RESULT IN SERIOUS BODILY HARM AND VOID PRODUCT WARRANTY. MANUFACTURER WILL ASSUME NO LIABILITY FOR LOSS OR DAMAGE OF ANY KIND, EXPRESSED OR IMPLIED, RESULTING FROM IMPROPER INSTALLATION OR USE OF THIS PRODUCT.

PLEASE READ ENTIRE MANUAL PRIOR TO INSTALLATION

STEP 1 (Selecting Site)

Before installing your new lift, check the following.

1. **LIFT LOCATION:** Always use architectural plans when available. Check the layout dimension against the floor plan requirements making sure that adequate space is available.
2. **OVERHEAD OBSTRUCTIONS:** The area where the lift will be located should be free of overhead obstructions such as heaters, building supports, electrical lines etc.
3. **DEFECTIVE FLOOR:** Visually inspect the site where the lift is to be installed and check for cracked or defective concrete.



4. Lift is designed for **INDOOR INSTALLATION ONLY**. Outdoor use permitted only if covered and dry. Always follow warnings illustrated on equipment labels.

STEP 2 (Floor Requirements)



This lift must be installed on a solid level concrete floor with no more than 3-degrees of slope. Failure to do so could cause personal injury or death.

A level floor is suggested for proper use and installation and level lifting. If a floor is of questionable slope, consider a survey of the site and/or the possibility of pouring a new level concrete slab.



- ◆ DO NOT install or use this lift on any asphalt surface or any surface other than concrete.
- ◆ DO NOT install or use this lift on expansion seams or on cracked or defective concrete.
- ◆ DO NOT install or use this lift on a second / elevated floor without first consulting building architect.
- ◆ DO NOT install or use this lift outdoors.

CONCRETE SPECIFICATIONS

LIFT MODEL	CONCRETE REQUIREMENTS
XR-12000	4" Min. Thickness / 3,000 PSI
XR-12000A	4" Min. Thickness / 3,000 PSI



DANGER!

ALL MODELS MUST BE INSTALLED ON 3000 PSI CONCRETE ONLY CONFORMING TO THE MINIMUM REQUIREMENTS SHOWN ABOVE. NEW CONCRETE MUST BE ADEQUATELY CURED FOR A MINIMUM OF 28 DAYS.

IMPORTANT NOTE

BendPak lifts are supplied with installation instructions and concrete fasteners meeting the criteria as prescribed by the American National Standard "Automotive Lifts - Safety Requirements for Construction, Testing, and Validation" ANSI/ALI ALCTV-2006. Lift buyers are responsible for any special regional structural and/or seismic anchoring requirements specified by any other agencies and/or codes such as the Uniform Building Code (UBC) and/or International Building Code (IBC).



When removing the lift from shipping angles, pay close attention as the ramps can slide and can cause injury. Prior to removing the bolts make sure the ramps are held securely by a fork lift or some other heavy lifting device.

PARTS INVENTORY

Be sure to take a complete inventory of parts prior to beginning installation.

Description	Qty
Power Unit Console	1
Left Ramp Assembly	1
Right Ramp Assembly	1
Drive-Up Ramps	2
Alignment Turnplate (XR-12000A only)	2
Work Step	2
Parts Box (Packing List Enclosed)	1
Parts Bag (Packaged in Part Box)	1

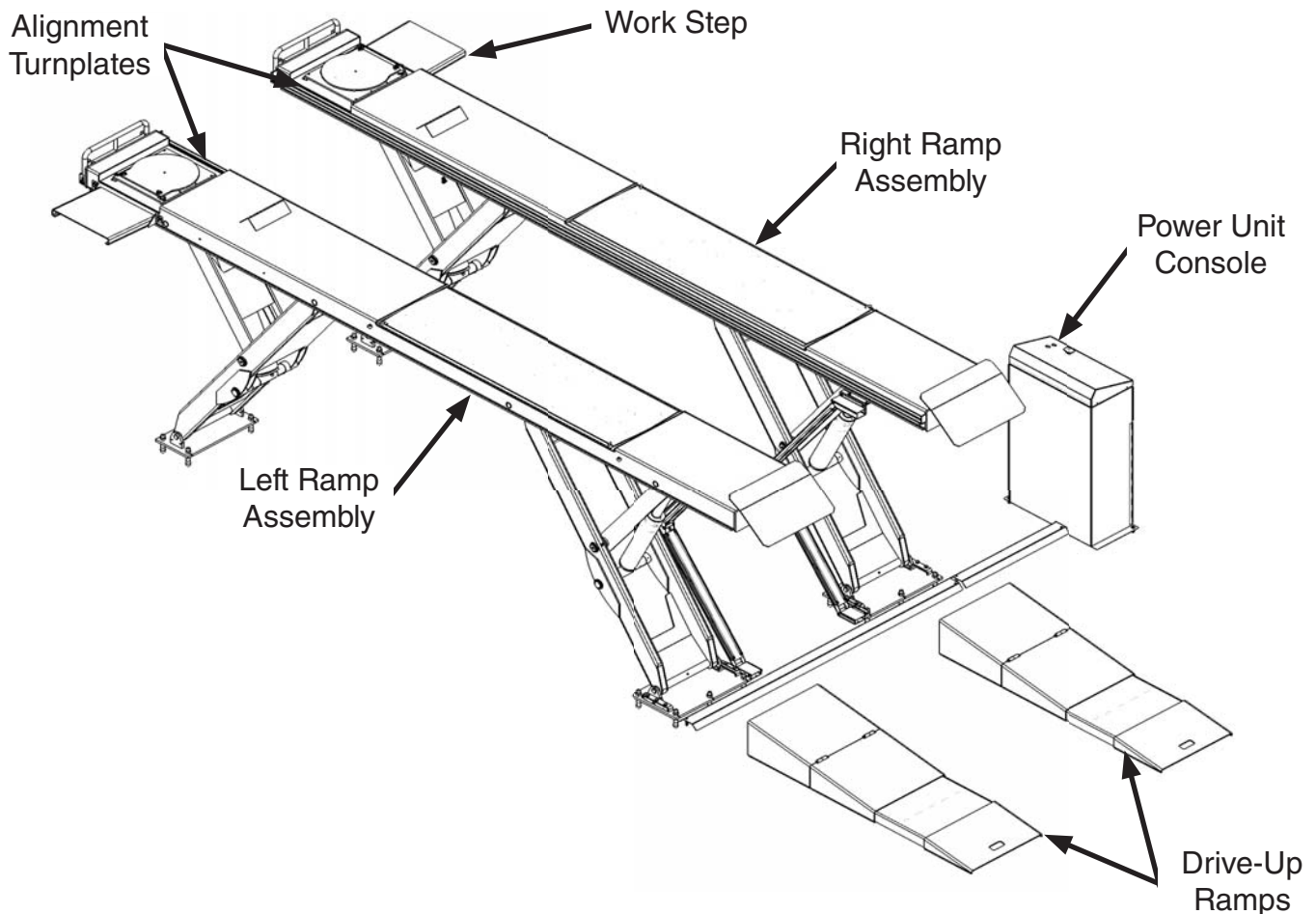

*Note: For reference only. Not assembly instruction

FLOOR PLAN / GENERAL SPECIFICATIONS

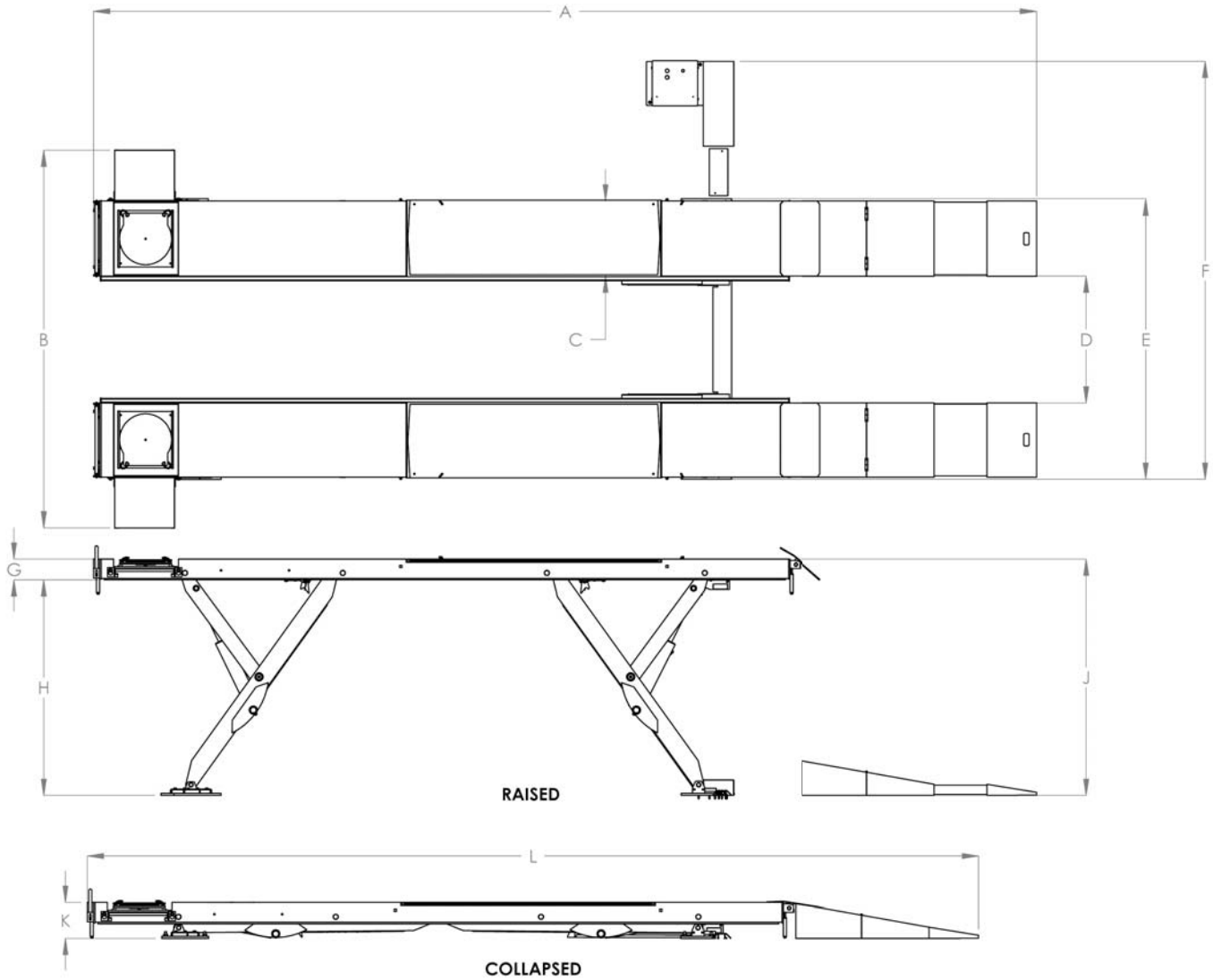

Measurement	XR-12000	XR-12000A
A - Overall Extended Length	276.7" / 7029mm	300.3" / 7627mm
B - Width w/ Steps	120.4" / 3057mm	120.4" / 3057mm
C - Ramp Width	23.8" / 604mm	23.8" / 604mm
D - Between Ramps	40.5" / 1028mm	40.5" / 1028mm
E - Overall Width (Baseplate to Baseplate)	89.5" / 2272mm	89.5" / 2272mm
F - Overall Width w/ Console	133.3" / 3385mm	133.3" / 3385mm
G - Ramp Height	6.6" / 168mm	6.6" / 168mm
H - Underramp Height	68.5" / 1741mm	68.5" / 1741mm
J - Raised Height	75.2" / 1910mm	75.2" / 1910mm
K - Collapsed Height	11.75" / 298mm	11.75" / 298mm
L - Overall Collapsed Length	257.5" / 6547mm	283.5" / 7201mm
Minimum 4 Wheel Alignment Wheelbase*	n/a	100" / 2540mm
Maximum 4 Wheel Alignment Wheelbase*	n/a	165" / 4191mm
Maximum 2 Wheel Alignment Wheelbase*	n/a	172" / 4369mm
Minimum General Wheelbase*	140" / 3556mm	140" / 3556mm
Maximum General Wheelbase*	178" / 4521mm	178" / 4521mm
Standard Motor **	220 VAC / 50/60Hz 1 Ph	220 VAC / 50/60Hz 1 Ph
Maximum Operating Pressure	2800 PSI	2800 PSI
(*) May vary depending on wheel size (**) Special Voltages Available upon Request.		

LAYOUT

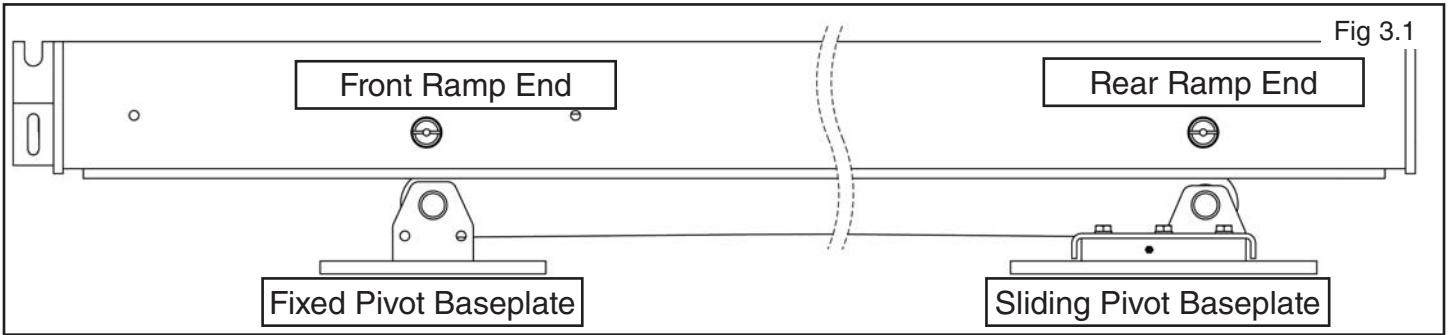

STEP 3 (Site Layout)

1. Select an appropriate site for where to install your new state-of-the-art BendPak lift using the chart on page 10.
2. Now determine which direction you would like the lift to face. A vehicle will approach the lift from the Rear Ramp End and drive forward to the Front Ramp End. (See Fig 3.1)
3. Once a location is determined, use a carpenter's chalk line to layout a grid for the Sliding Pivot Baseplate locations. Make sure to snap the chalk line long enough for the entire length of the ramp. This is needed to provide a reference line for the Fixed Pivot Baseplates, as these baseplates are narrower.

4. All measurements are made from Baseplate center anchor holes.

6. Keep all dimensions square within 1/8" (3mm) or malfunction of the lift can occur.



WARNING!
KEEP ALL DIMENSIONS SQUARE WITHIN 1/8" OR MALFUNCTION OF LIFT MAY OCCUR

7. CHECK ALL DIMENSIONS TWICE and make sure that the layout is perfectly square.

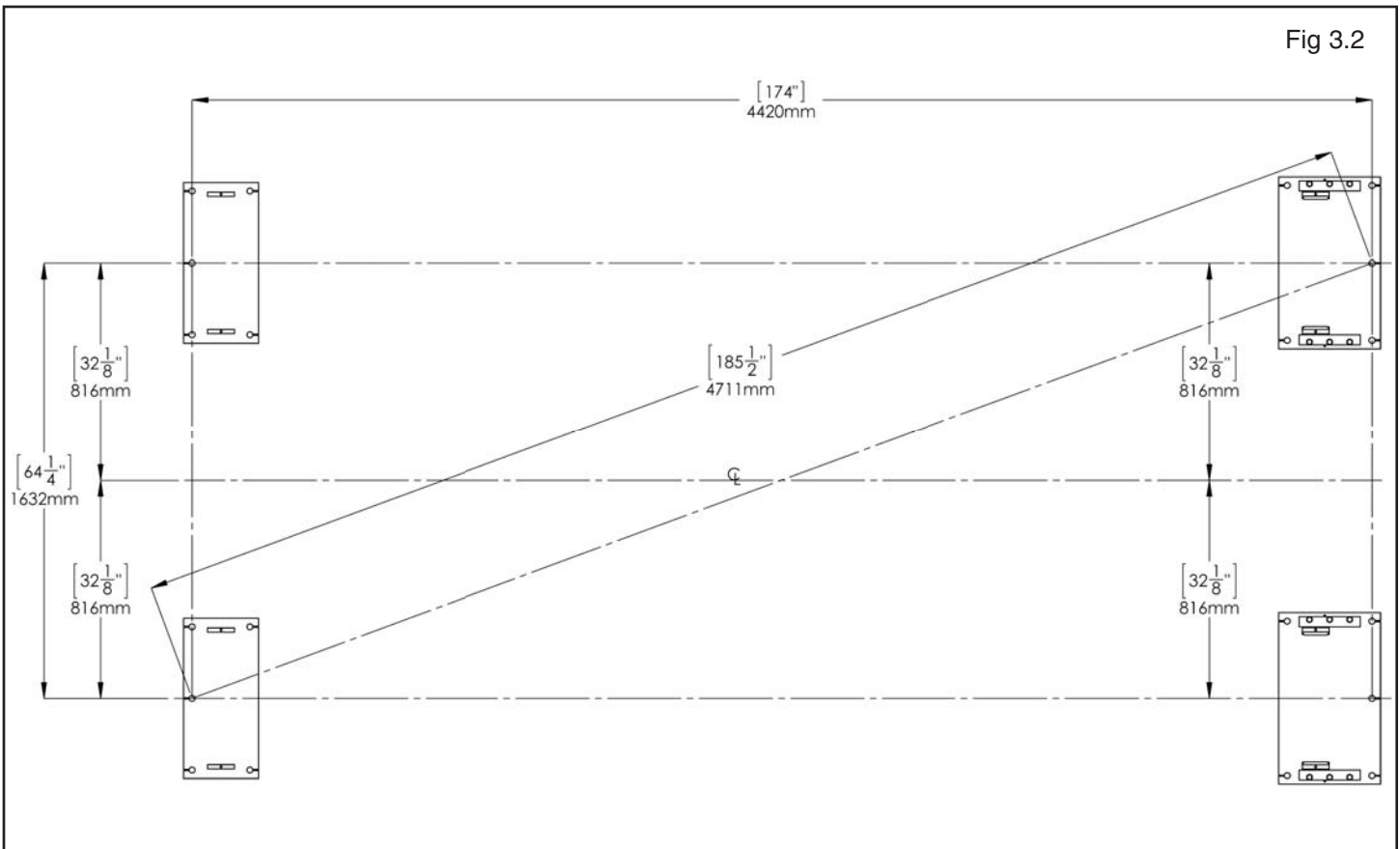

STEP 4 (Aligning the Ramp Assemblies)

1. Lift the Left Ramp Assembly and Right Ramp assembly into position and set the ramps down on to the layout created in Step 3

2. Align the Sliding Pivot Baseplates with the chalklines that were drawn in Step 3. (See Fig 4.1)

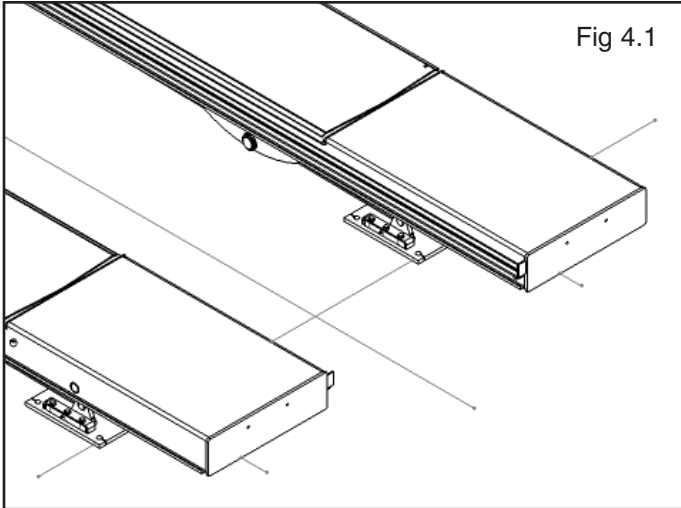

3. Align the Fixed Pivot Baseplates with the chalklines that were drawn in Step 3, using care so that the Sliding Pivot Baseplates do not shift during alignment. (See Fig 4.2)

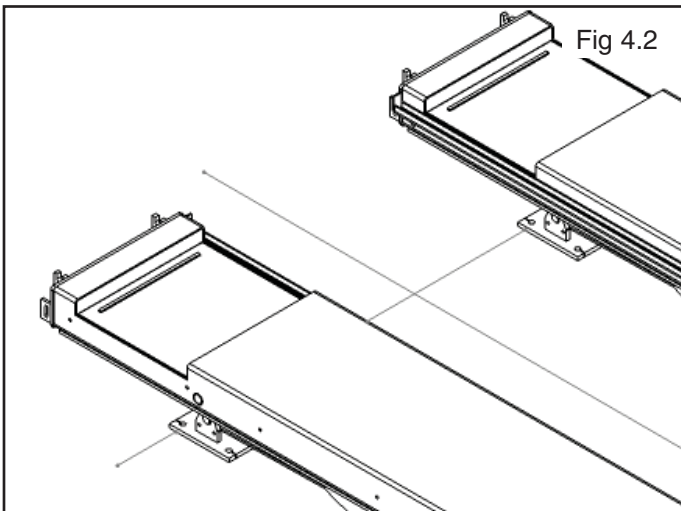

4. DO NOT attempt to bolt down the ramp assemblies at this time.

STEP 5 (Power Unit Console Installation)

1. Place the Power Unit Console next to the Right Ramp Assembly's Sliding Pivot Baseplate and align it using the measurements as shown in Figure 5.1

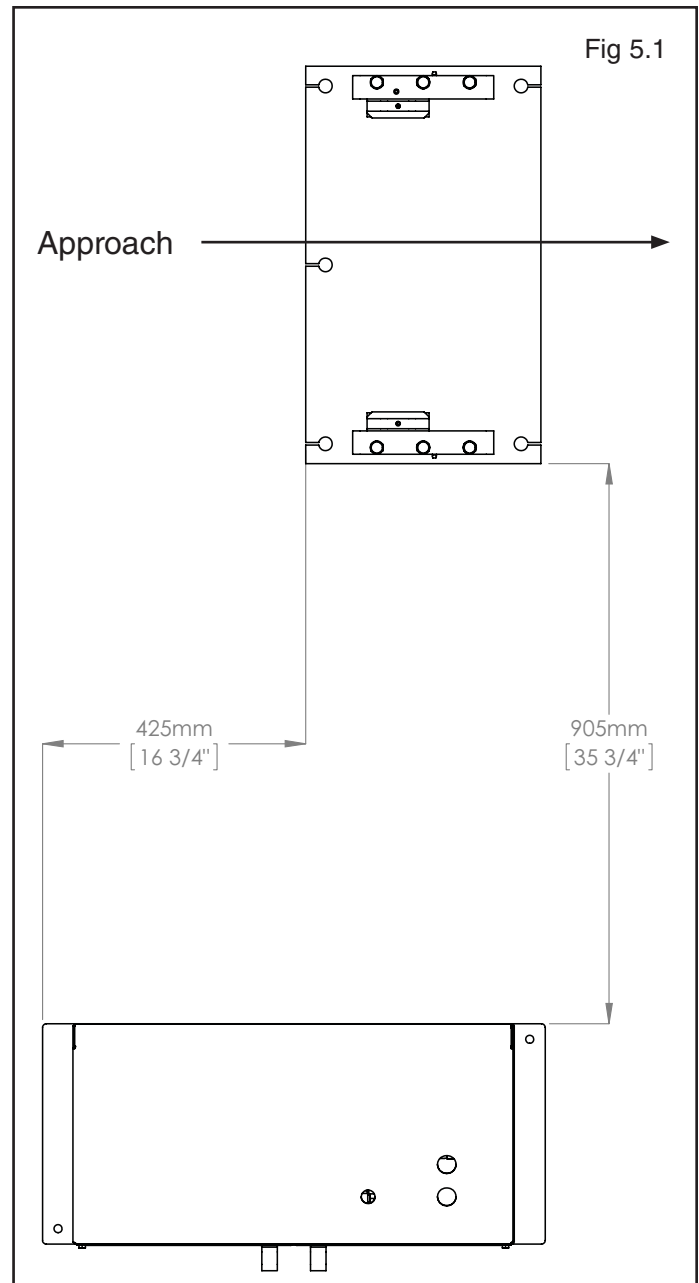

2. Using the console's baseplate as a guide drill two 3/8" holes into the concrete floor 1-1/2" deep making sure not to let the drill wobble. DO NOT ream the holes after drilling. (See Fig 5.2)

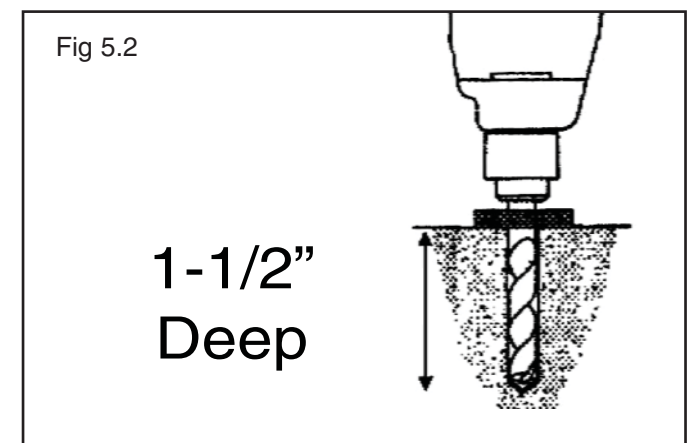

3. After drilling, remove dust thoroughly from each hole.
4. Assemble the washers and nuts on the anchors then tap into each hole with a hammer until the washer rests against the base plate. If shimming is required be sure that enough threads are left exposed. (See Fig. 5.3)

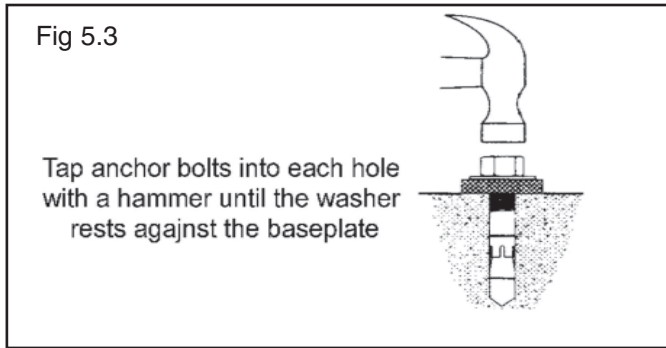

5. With anchor bolts in place, tighten by securing the nut to the base then turning 2-3 full turns clockwise. DO NOT use an impact wrench for this procedure. (See Fig. 5.4)

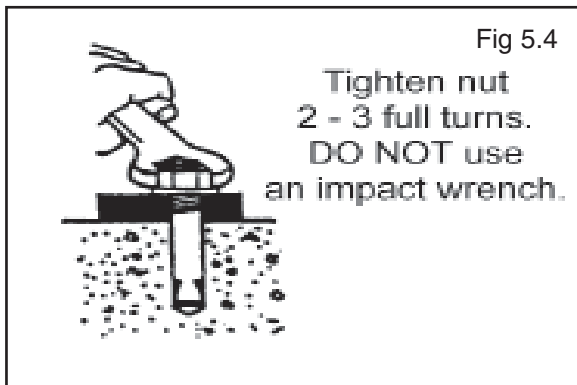

STEP 6 (Hydraulic Hose Connection)

1. Open the front doors of the Power Unit Console to access power unit and controls.
2. Your new lift has been pre-plumbed with hydraulic hoses. Connect the pre-marked hose ends to the corresponding marked port on the valve block assembly. (Ex. - S1 is connected to S1, etc) (See Fig 6.1)

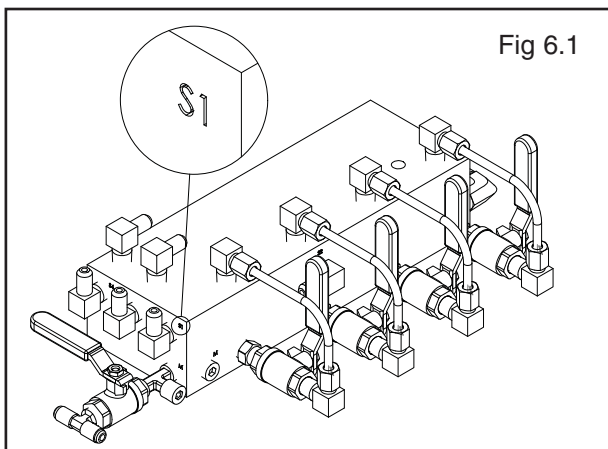

3. Remove port plug from the both ports in the Power Unit and install the 90° Fitting w/ O-ring into the Power Port (front port) and the 90° NPT fitting into the return port (rear port). Connect the Ø10mm Power Unit Hose Assembly to the power port and the Ø6.4mm Tank Hose to the return port.

4. Connect the Power Unit Hose Assembly to the Valve Block Assembly.
5. Connect the other end of the Tank Hose to the valve branching from the tee fitting at the bottom of the Valve Block Assembly.
6. Connect the other two hoses to the tee fitting located at the bottom of the entire Valve Block Assembly.
7. Cover the grouping of hoses temporarily with the long hose cover to prevent tripping over the hoses. Align the cutouts of the cover to the hose troughs so that the hoses may pass through in the cut outs. The cover plate will be anchored at a later time.



CAUTION!
DURING HOSE INSTALLATION, LOOSE HOSES POSE A TRIPPING HAZARD. BE AWARE OF LOOSE HOSES IN THE WORKSPACE TO AVOID INJURY.

STEP 7 (Safety Air Line Connection)

1. Your new lift has been pre-plumbed with 1/4" Poly-Flo air line hoses. Uncoil the air line hoses for both the Left and Right Ramp Safety Assemblies. (See Page 16 for routing diagram)
2. Starting with the air line on the Left Ramp Safety Assembly at the front of the lift, follow the same route with the air line as that of the hydraulic hoses.

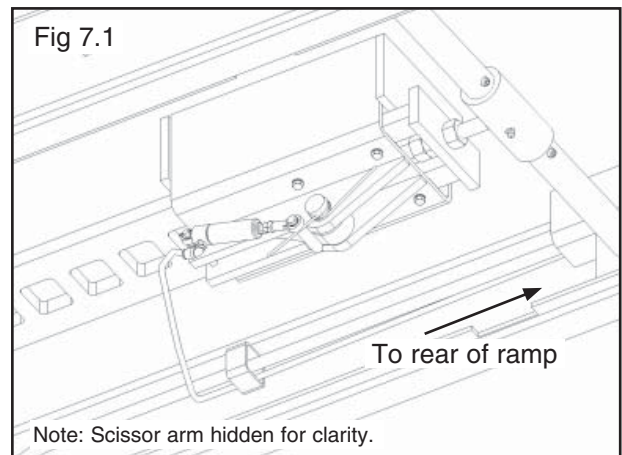

3. Once the air line hose route has reached the Left Ramp Assembly's Rear Safety, cut the air line hose and connect a Tee fitting to the air line end. (See Fig 7.2)

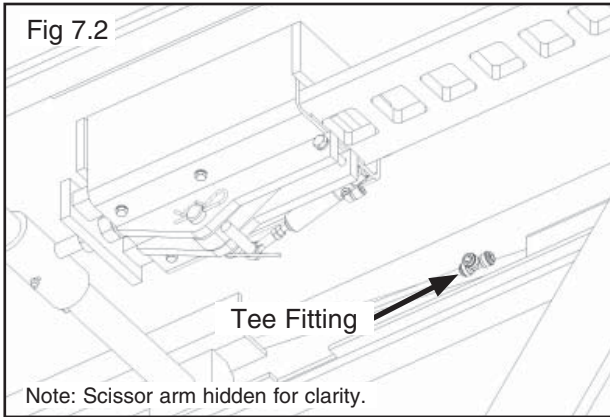

4. Connect a short section of the air line from the Rear Safety to the Tee fitting.

5. Route the air line hose down the left hand hose trough and through the floor cover to the opening for the right hand hose trough. (See Fig 7.3)

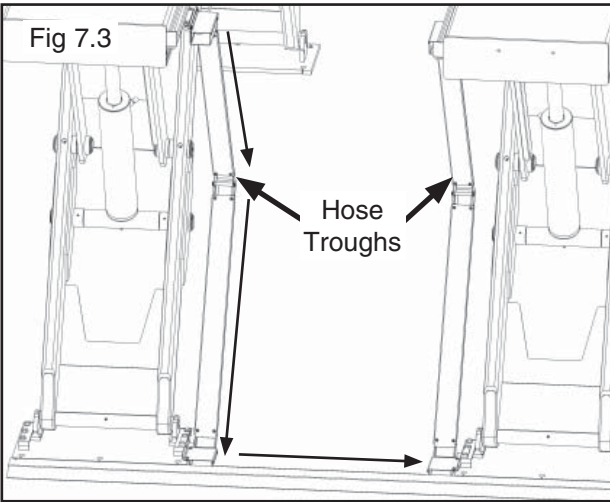

6. Cut the line and attach a Tee fitting.
7. Repeat items 1-5 for the Right Ramp Assembly.
8. Connect the air line from the Right Ramp Assembly to the Tee fitting from item 6.
9. Route the air line into the Power Unit Console and connect it to the Air Push Button. (See Fig 7.4)

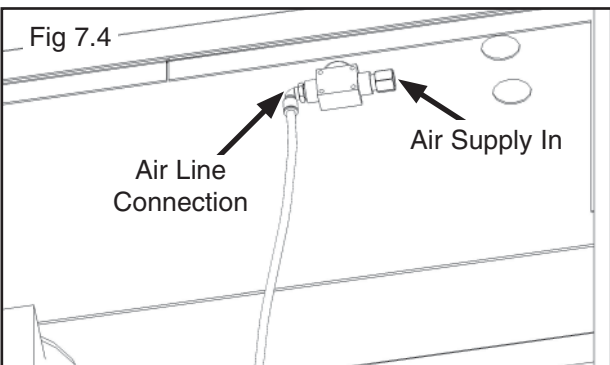

10. Connect the Air Push Button to your compressed air supply. Be sure that your compressed air supply does not exceed 125 PSI.

STEP 8 (Power Unit Electrical Connection)

1. The standard power unit for your lift is 220 volt, 60HZ, single phase. All wiring must be performed by a certified electrician only. SEE WIRING INSTRUCTIONS AFFIXED TO MOTOR FOR PROPER WIRING INSTRUCTIONS.
2. Route Power Cable through the hole in rear of Power Unit Console.



DANGER !
ALL WIRING MUST BE PERFORMED
BY A LICENSED ELECTRICIAN.



DANGER!
DO NOT PERFORM ANY MAINTENANCE OR
INSTALLATION OF ANY COMPONENTS WITHOUT
FIRST ENSURING THAT ELECTRICAL POWER HAS
BEEN DISCONNECTED AT THE SOURCE OR PANEL
AND CANNOT BE RE-ENERGIZED UNTIL ALL
MAINTENANCE AND/OR INSTALLATION
PROCEDURES ARE COMPLETED.

WARNING!
DO NOT RUN POWER UNIT WITHOUT OIL. DAMAGE TO
POWER UNIT PUMP CAN OCCUR. THE POWER UNIT
MUST BE KEPT DRY. DAMAGE TO POWER UNIT CAUSED
BY WATER OR OTHER LIQUIDS SUCH AS DETERGENTS,
ACID ETC., IS NOT COVERED UNDER WARRANTY.

OPERATE LIFT ONLY BETWEEN TEMPERATURES OF
41° - 104° F. IMPROPER ELECTRICAL HOOK-UP CAN
DAMAGE MOTOR AND WILL NOT BE COVERED UNDER
WARRANTY. MOTOR CAN NOT RUN ON 50HZ WITHOUT
A PHYSICAL CHANGE IN THE MOTOR.

USE A SEPARATE CIRCUIT BREAKER FOR EACH POWER
UNIT. PROTECT EACH CIRCUIT WITH TIME DELAY FUSE
OR CIRCUIT BREAKER.

FOR 208-230 VOLT, SINGLE PHASE, USE A 25 AMP FUSE.
FOR 208-230 VOLT, THREE PHASE, USE A 20 AMP FUSE.
FOR 380-440 VOLT, THREE PHASE, USE A 15 AMP FUSE.

HYDRAULIC HOSE ROUTING DIAGRAM

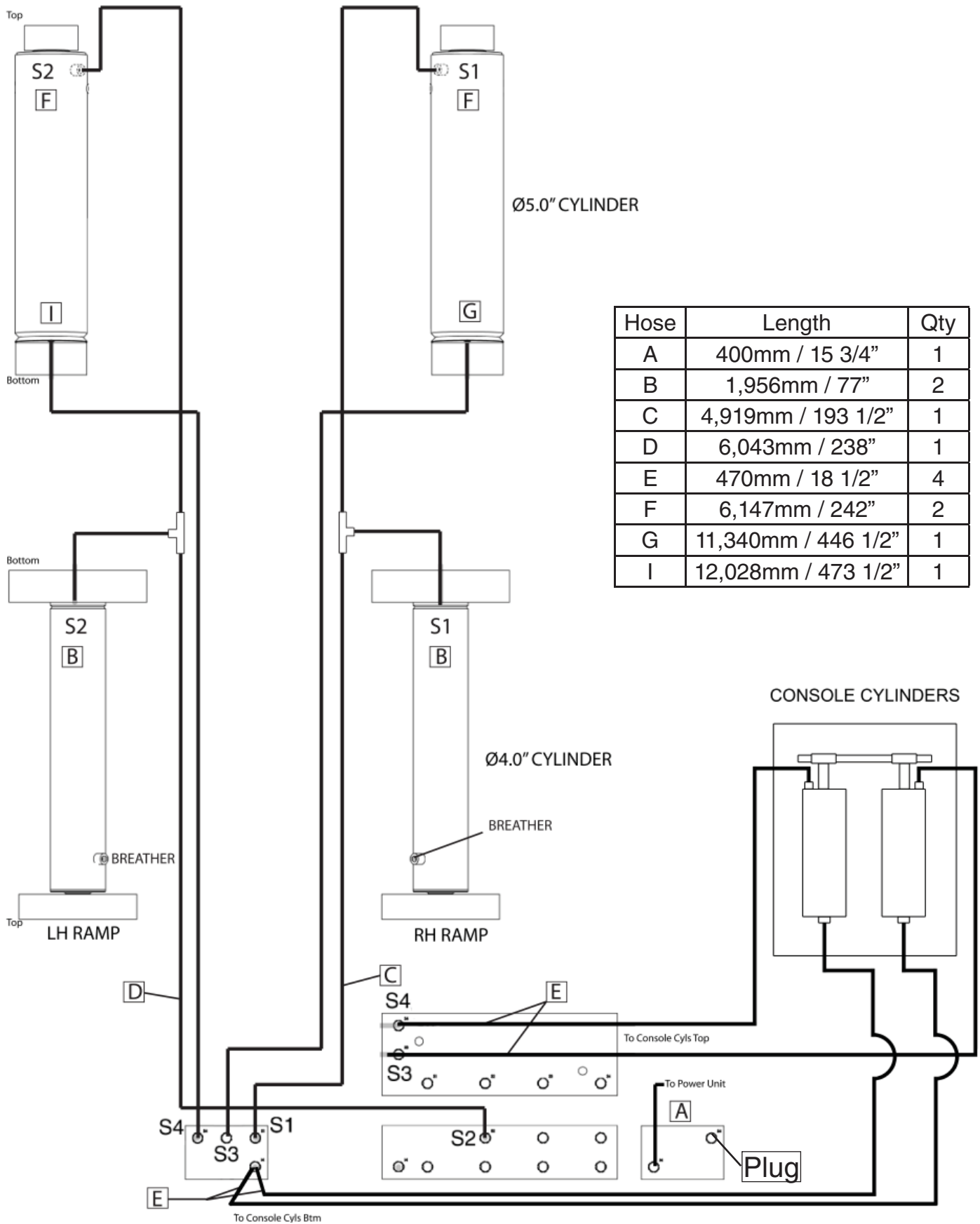

SAFETY AIR LINE ROUTING DIAGRAM

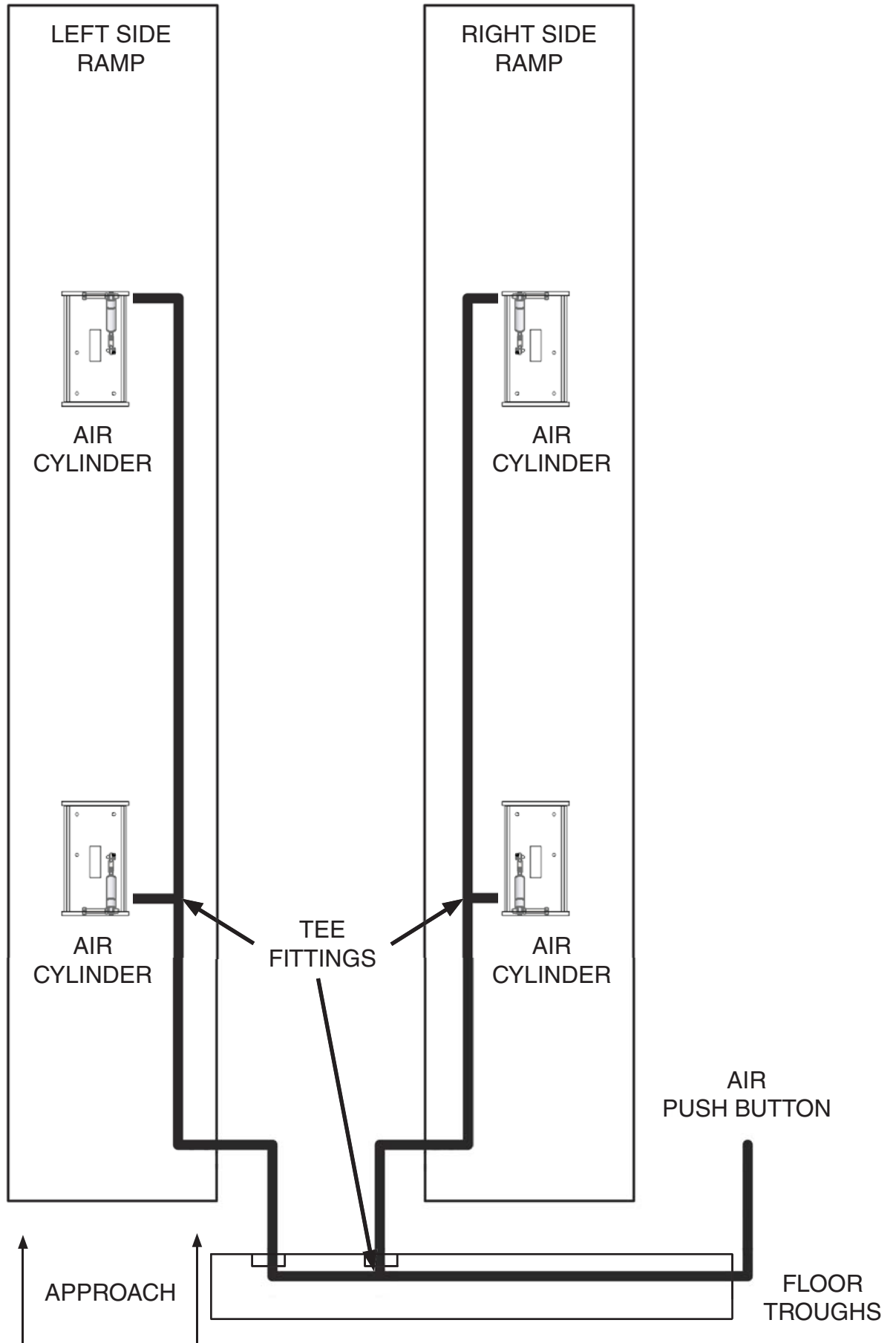

220V Wiring Diagram

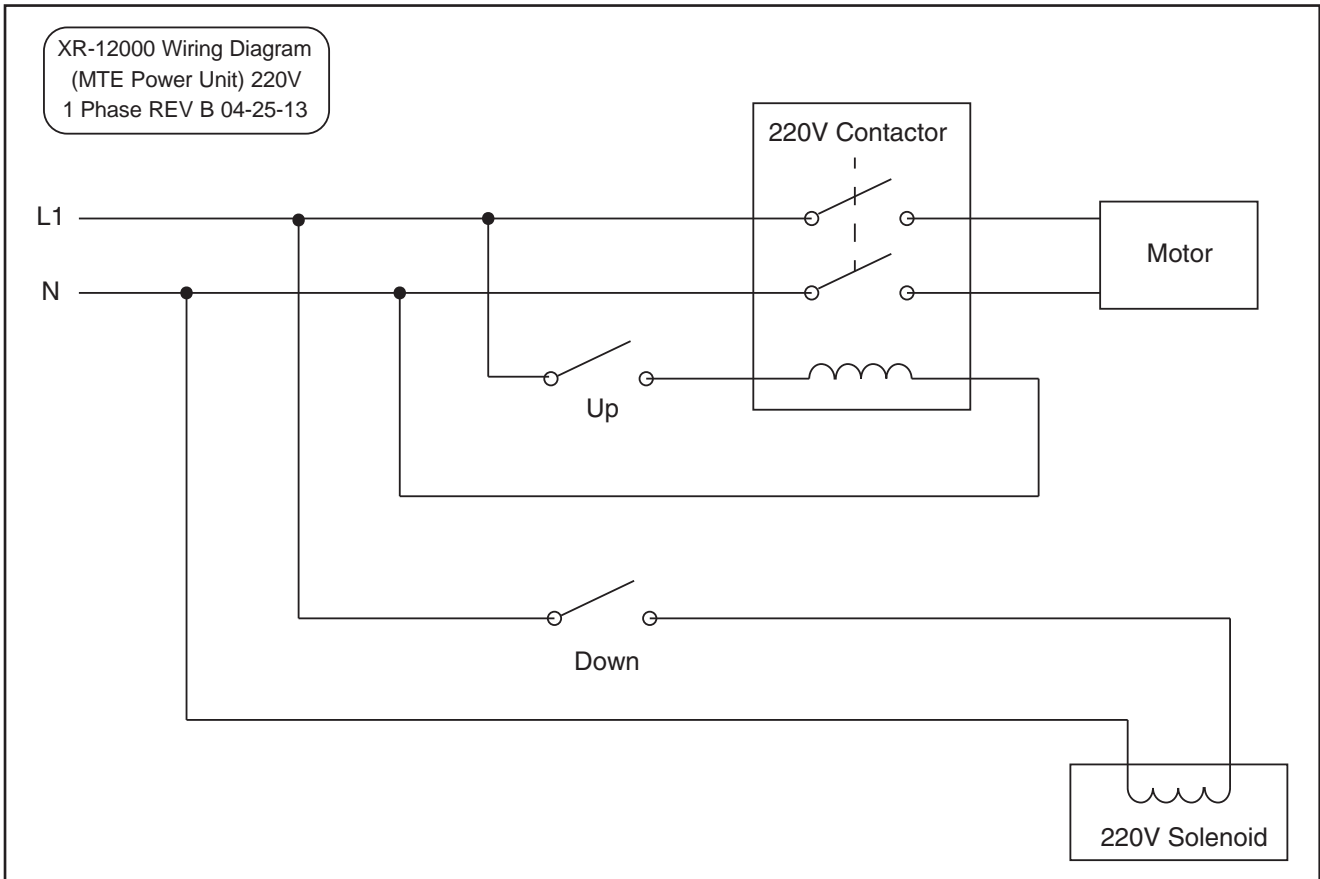

380V Wiring Diagram

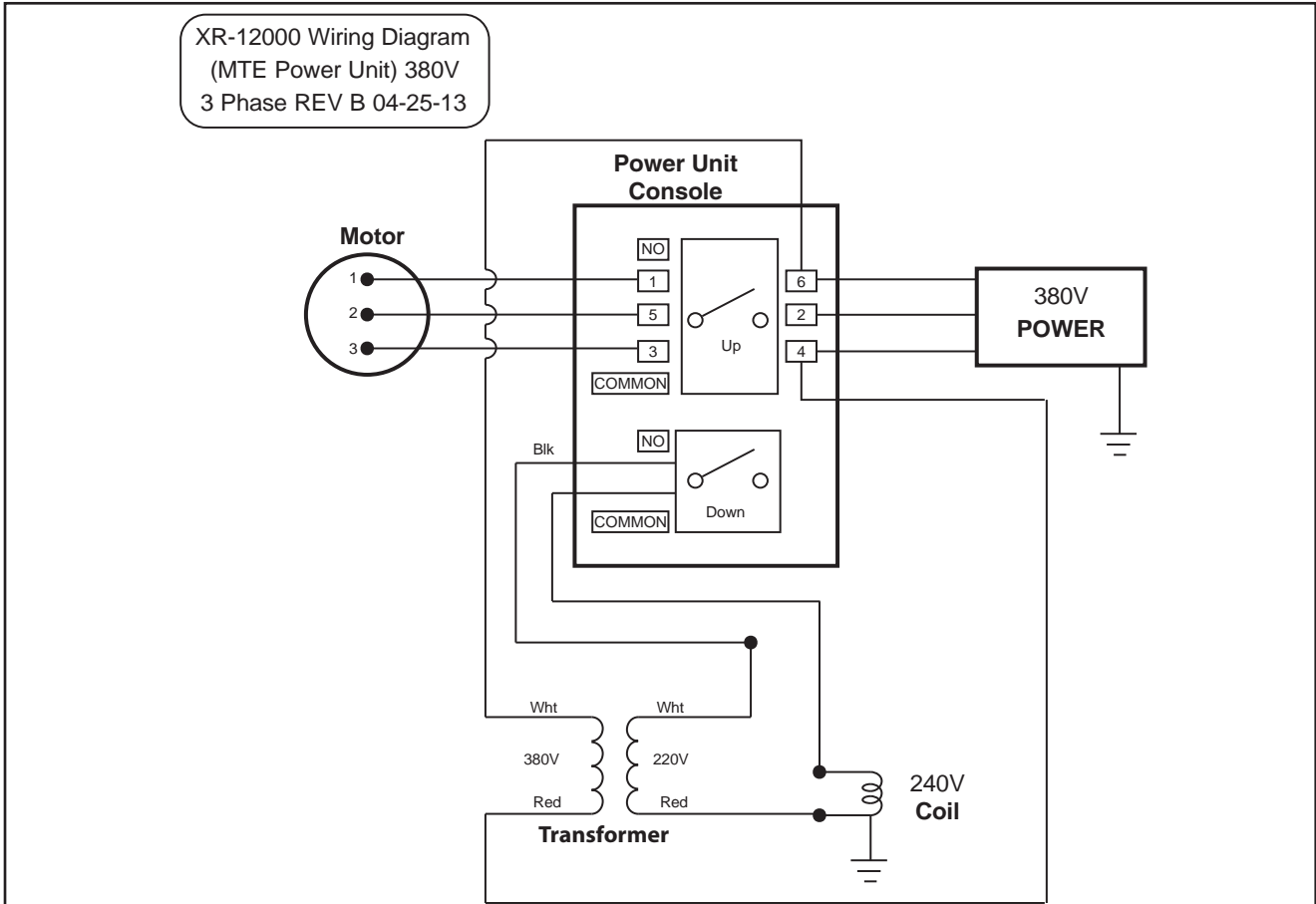



DANGER!

DO NOT PERFORM ANY MAINTENANCE OR INSTALLATION OF ANY COMPONENTS WITH OUT FIRST ENSURING THAT ELECTRICAL POWER HAS BEEN DISCONNECTED AT THE SOURCE OR PANEL AND CANNOT BE RE-ENERGIZED UNTIL ALL MAINTENANCE AND/OR INSTALLATION PROCEDURES ARE COMPLETED.



IMPORTANT POWER-UNIT INSTALLATION NOTES

- DO NOT run power unit without oil. Damage to pump can occur.
- The power unit must be kept dry. Damage to power unit caused by water or other liquids such as detergents, acid etc., is not covered under warranty.
- Improper electrical connection can damage motor and will not be covered under warranty.
- Motor can not run on 50HZ without a physical change in the motor.
- Use a separate breaker for each power unit.
- Protect each circuit with time delay fuse or circuit breaker.
- For 208-230 volt, single phase, use a 25 amp fuse.
- For 208-230 volt, three phase, use a 20 amp fuse.
- For 380-440 volt, three phase, use a 15 amp fuse.

Installation and adjustment.

DO NOT attempt to raise vehicle until a thorough operation check has been completed.

All wiring must be performed by a certified electrician only.

Single Phase

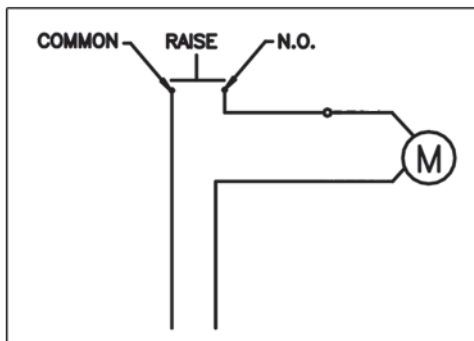

Three Phase

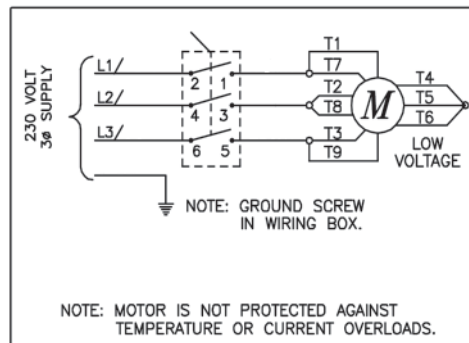

SEE WIRING INSTRUCTIONS AFFIXED TO
MOTOR FOR PROPER WIRING INSTRUCTIONS.

STEP 9 (Anchoring the Ramps)

NOTE:

BENDPAK LIFTS ARE SUPPLIED WITH INSTALLATION INSTRUCTIONS AND CONCRETE FASTENERS MEETING THE CRITERIA AS PRESCRIBED BY THE AMERICAN NATIONAL STANDARD "AUTOMOTIVE LIFTS - SAFETY REQUIREMENTS FOR CONSTRUCTION, TESTING, AND VALIDATION" ANSI/ALI ALCTV-2006. LIFT BUYERS ARE RESPONSIBLE FOR ANY SPECIAL REGIONAL STRUCTURAL AND/OR SEISMIC ANCHORING REQUIREMENTS SPECIFIED BY ANY OTHER AGENCIES AND/OR CODES SUCH AS THE UNIFORM BUILDING CODE (UBC) AND/OR INTERNATIONAL BUILDING CODE (IBC).

1. Before proceeding, make certain the lift is positioned with proper clearances around and overhead.

NOTE:

A LEVEL FLOOR IS SUGGESTED FOR PROPER INSTALLATION. SMALL DIFFERENCES IN FLOOR SLOPE MAY BE COMPENSATED FOR BY PROPER SHIMMING. ANY MAJOR SLOPE DIFFERENCES WILL AFFECT LEVEL LIFTING. IF A FLOOR IS OF QUESTIONABLE SLOPE, (MORE THAN 1" SIDE TO SIDE OR 2" WITHIN THE FULL LENGTH OF THE LIFT) CONSIDER POURING A NEW CONCRETE SLAB.



WARNING!

WHERE IT IS DESIRED TO RAISE THE BASE OF THE LIFT TO ACHIEVE LEVEL, THE ENTIRE FOOTPRINT OF THE BASE FRAME MUST BE FULLY SUPPORTED UNDERNEATH WITH STEEL PLATES OR CONCRETE. FAILURE TO DO SO WILL DAMAGE THE LIFT. THIS LIFT WAS DESIGNED TO BE A FLOOR MOUNT.

2. Using the base of the frame as a guide, drill each anchor hole in the concrete approximately 4" deep using a rotary hammer drill and 3/4" concrete drill-bit. (See Fig 9.1)

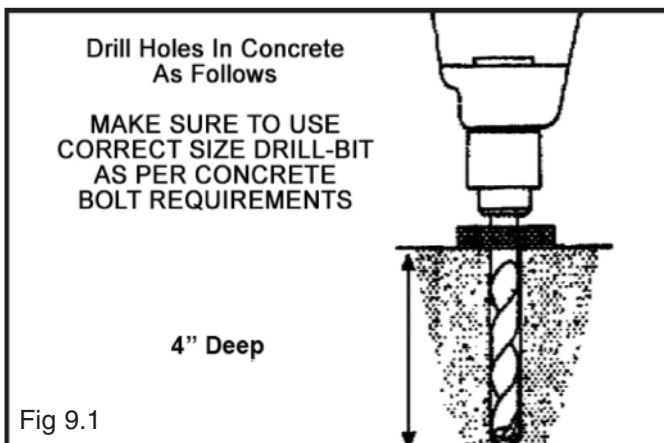

3. After drilling the anchor holes, remove the dust thoroughly from each hole using compressed air and/or wire brush. ALWAYS WEAR SAFETY GOGGLES.

4. Assemble the washers and nuts on the anchors then tap into each hole with a hammer until the washer rests against the baseplate. Be sure that if shimming is required, enough threads are left exposed. (See Fig. 9.2)

Fig 9.2

Tap anchor bolts into each hole with a hammer until the washer rests against the baseplate

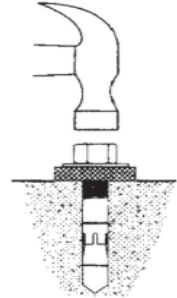

5. With the shims and Anchor Bolts in place, tighten nut three to five turns past finger tight. DO NOT use an impact wrench for this procedure. (See Fig. 9.3)

Tighten Nut
3-5 Turns.
Do Not Use
Impact Wrench!

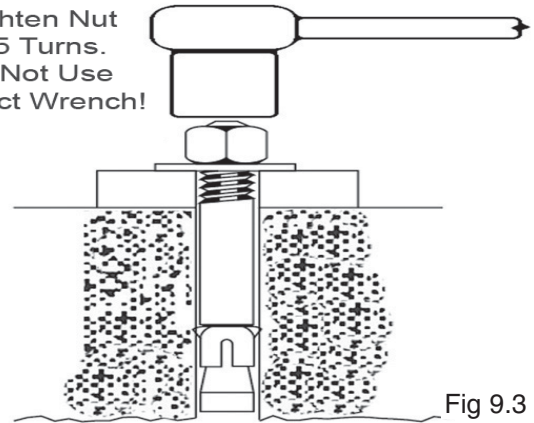

Fig 9.3

STEP 10 (Installing Approach Ramps)

1. With the ramps in the collapsed position, place the Approach ramps centered with the Left and Right ramp assemblies making sure there is a 3-3/4" gap in between each respective ramp assembly and Approach Ramp. (See Fig 10.1)

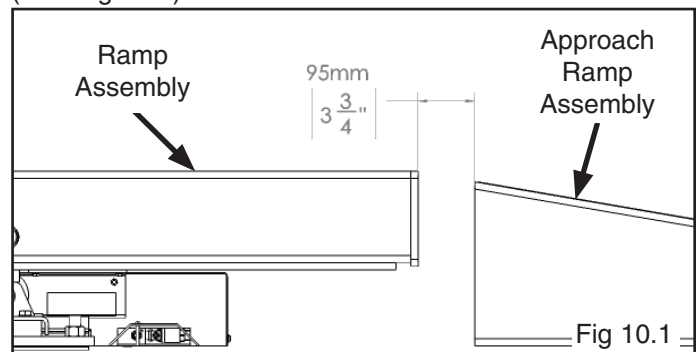
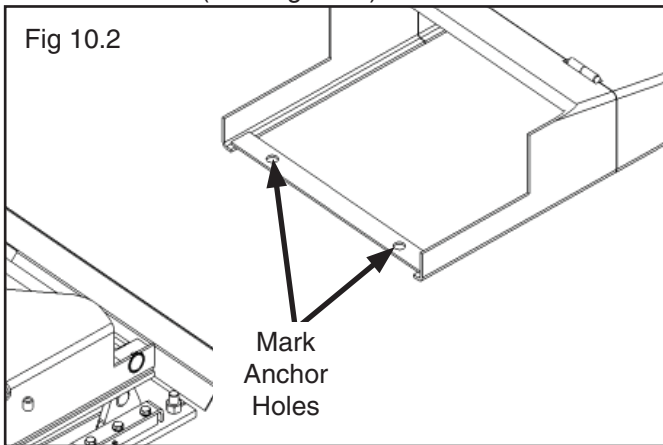
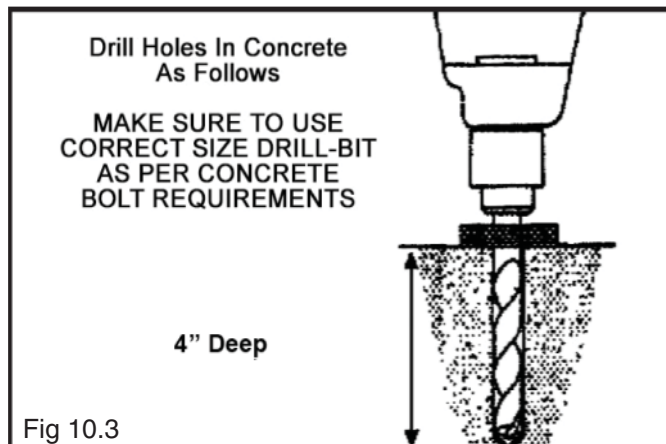

Fig 10.1

2. Using chalk or crayon, mark the floor anchor bolt holes on the concrete. (See Fig. 10.2)



3. Remove the approach ramps and drill each anchor hole for the approach ramps in the concrete approximately 4" deep using a rotary hammer drill and 3/4" concrete drill-bit. (See Fig 10.3)



4. After drilling the anchor holes, remove the dust thoroughly from each hole using compressed air and/or wire brush. ALWAYS WEAR SAFETY GOGGLES.

5. Replace the approach ramps and align the holes that were drilled in the concrete with the anchor holes on the approach ramps.

6. Assemble the washers and nuts on the anchors then tap into each hole with a hammer until the washer rests against the base. (See Fig. 10.4)

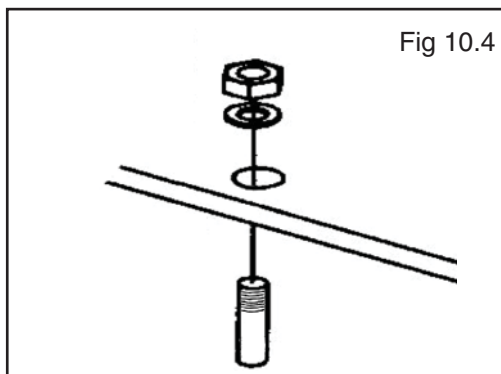

6. With the shims and Anchor Bolts in place, tighten nut three to five turns past finger tight. DO NOT use an impact wrench for this procedure. (See Fig. 10.5)

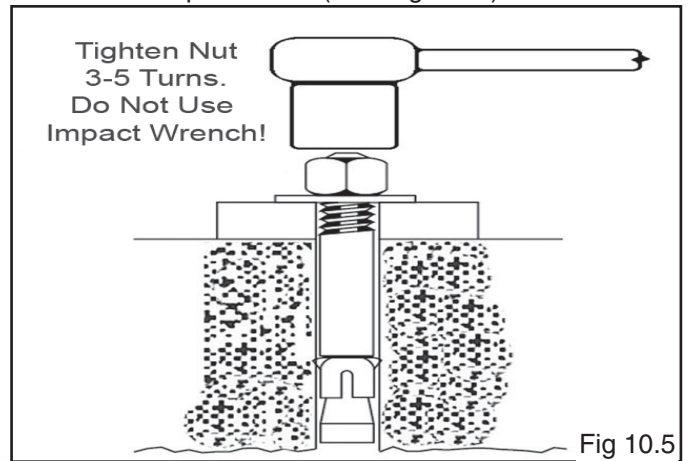

STEP 11 (Installing Accessories)

1. Place the Turnplates in the Turnplate pockets (Alignment Model Only). Level the Turnplate Pockets as shown in Step 17 on page 26.

2. Install the Front Tire stops using the Hinge Pins and C-clips as shown. (See Fig. 11.1)

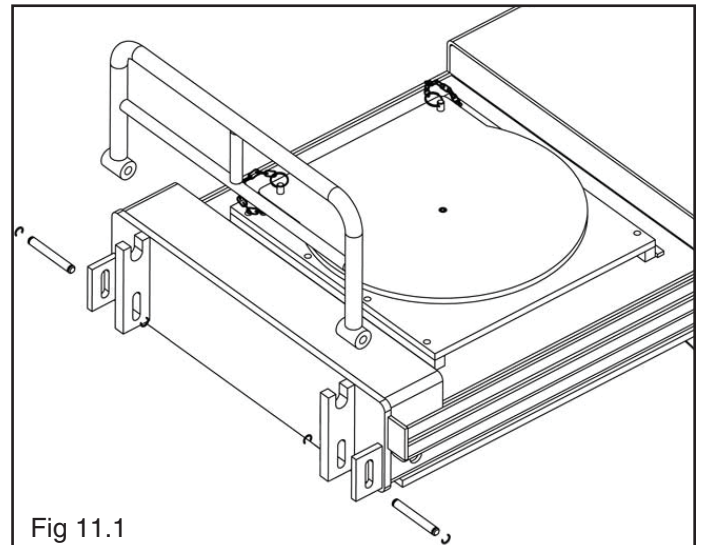

3. Install the Flip Up Ramps using the Flip Up ramp Bracket Pins and C-clips as shown. (See Fig. 11.2)

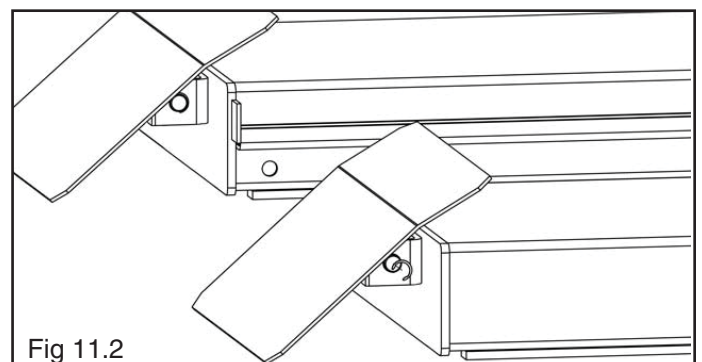

4. Insert the Rollback Spacer Bars between the Turnplate as needed for alignment procedures. (See Fig 11.3)

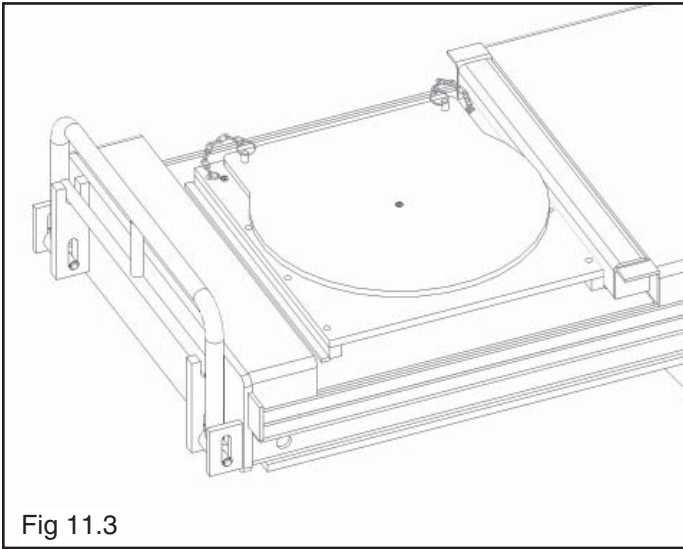

Fig 11.3

STEP 12 (Final Assembly)

1. Tighten all assembly and Anchor Bolts securely.

STEP 13 (Safety Ladder Bolt Adjustment)



WARNING!

ALWAYS use jack stands for any service or maintenance. NEVER go under or reach under the lift unless jack stands are securely in place and power to the lift has been disconnected to prevent others from inadvertently operating the lift.

1. If the safety locks do not engage uniformly (operator hears all four safeties spring into position) when the lift is raised to the top most position then the Safety Ladder needs to be adjusted.

2. Raise the lift until the first safety engages the topmost safety position.



WARNING!

DO NOT work on or near raised lift until support stands are in place to support the platform. Always ensure support stands are engaged before any attempt is made to work on or near the lift

3. After determining which safeties are not engaging the Safety Ladder, loosen the jam nuts and adjust the position of the ladder until the safety springs into position. Do this for each disengaged Safety Ladder. (See Fig 13.1)

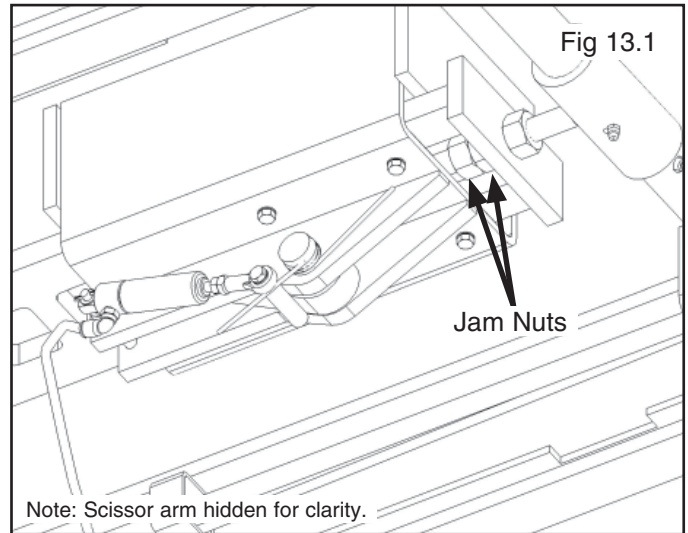

Fig 13.1

For more information on safety engagement see page 25.

STEP 14 (Hydraulic Air Bleeding and Leveling)



READ THE FOLLOWING START-UP INSTRUCTIONS CAREFULLY AND THOROUGHLY. PAY CLOSE ATTENTION TO EACH STEP AS DESCRIBED BELOW IN PRECISE ORDER. IF THESE INSTRUCTIONS ARE NOT FOLLOWED EXACTLY, DAMAGE TO THE LIFT CAN OCCUR WHICH IS NOT COVERED UNDER WARRANTY.

- To avoid personal injury, DO NOT ATTEMPT the following start-up and pre-leveling procedures with a vehicle on the runways.
- NEVER ATTEMPT any valve block adjustments with a vehicle on the runways at any time the lift is in operation.
- Never go under the lift runways or near any moving components until each scissor mechanism is securely blocked or the safety locks are fully engaged at all four corners to prevent accidental lowering of the lift.
- To avoid personal injury, stand clear of scissor leg mechanism while lift is in motion.
- ALWAYS use jack stands for any service or maintenance. NEVER go under or reach under the lift unless jack stands are securely in place and power to the lift has been disconnected to prevent others from inadvertently operating the lift. NEVER use jack stands with a load on the runways.

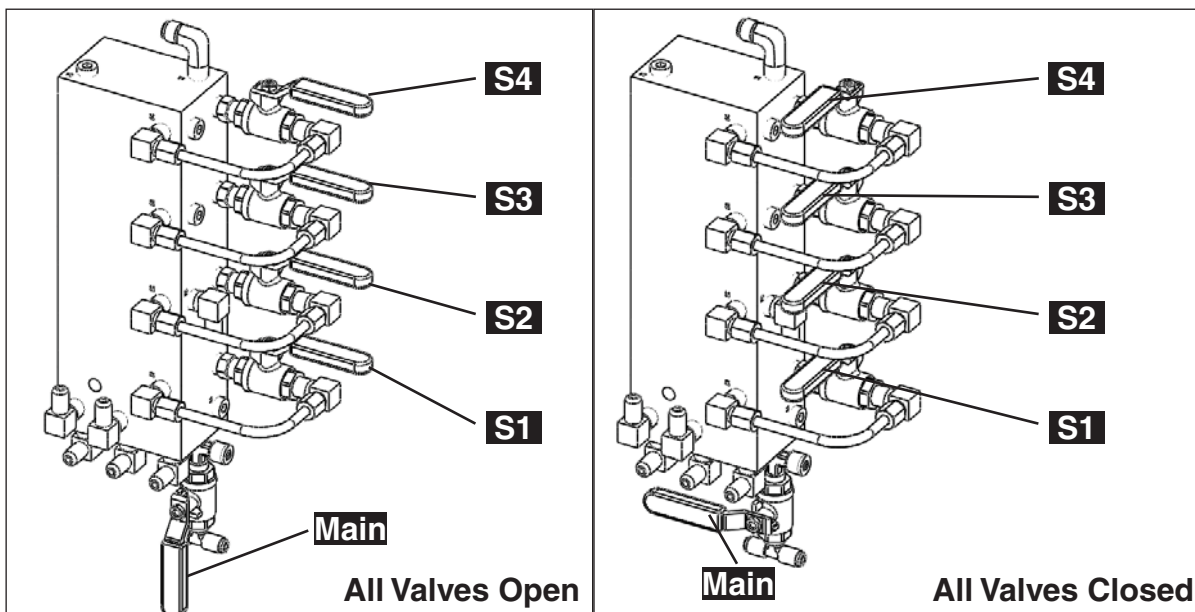

(Important Note: Never open block valves while simultaneously depressing the power console LOWER button unless specifically stated to do so.)

BLEEDING

STEP ONE - Hydraulic Air Bleeding - Filling the Console Cylinders

- Position the Main valve handle on the valve block to the **OPEN** position. Position all other valves to the **CLOSED** position.
- Press the RAISE button on the power console. This will extend the cylinders in the console. Tighten the bleed screws.
- When the lift ramps are 3-4' off of the ground, stop pressing the RAISE button and close the Main Valve Handle.
- Open the S3 and S4 Valve Handles.
- Press the LOWER button until both ramps have lowered to the floor.
- Close the S3 and S4 Valve Handles.
- Open the Main Valve Handle.

- Press the RAISE button. This will again extend the cylinders in the console while lifting both ramps. The ramps will not be even, this is normal.
- When the console cylinders have completely extended, the power unit sound will change. When this happens, stop pressing the RAISE button and close the Main Valve Handle.
- Open the S3 and S4 Valve Handles.
- Press the LOWER button until both ramps have lowered to the floor.
- Close all Valve Handles.
- Proceed to STEP TWO.

STEP TWO - Hydraulic Air Bleeding - Filling the Master Cylinders

- **OPEN** S3 and S4. **CLOSE** all other valves.

- Press the RAISE button until both ramps are approximately 3-4 feet off the ground.
- Stop pressing the RAISE button and close the S3 and S4 Valve Handles. All valve handles should be closed.
- Open the S1 and S2 Valve Handles.
- Press the LOWER button until the rear ends of the ramps are almost to the floor. The front ends of the ramps will still be raised.
- Close S1 and S2 Valve Handles.
- Open S3 and S4 Valve Handles.
- Press the RAISE button until the front ends of both ramps are fully raised. The rear ends of both ramps will not be fully raised. This is normal.
- Close the S3 and S4 Valve Handles.
- Open the S1 and S2 Valve Handles.
- Press the LOWER button until the rear of both ramps lower to the floor. The front of both ramps will still be raised. This is normal.
- Proceed to STEP THREE.

STEP THREE - Hydraulic Air Bleeding - Filling the Slave Cylinders

- **OPEN** the S1 and S2 Valve Handles.
- Press the RAISE button on the power console until the rear of the both ramps are fully raise and the power unit sound changes.
- **CLOSE** the S1 and S2 Valve Handles. All Valve Handles should be closed.
- Open the Main Valve Handle.
- Press the LOWER button until both ramps are lowered to the floor.
- This completes Bleeding of the Hydraulic System.
- Proceed to STEP FOUR.

LEVELING

STEP FOUR - Leveling - Equalizing Front to Back

- Open MAIN valve. All other valves should be closed.
- Press the RAISE button on the power console until both ramps are at a convenient height for checking level. Set the lift on locks.
- Check the lift level while on locks using a level.
- Press the RAISE button to lift the ramps off of the locks.
- Using the adjustabe threaded rods on the safety lock ladders adjust ladders as appropriate to assure lift is level on locks at your most commonly used height.
- Press the RAISE button to lift the ramps off of the locks.
- Close MAIN valve. All other valves should be closed.
- Check the level of the Right Ramp Assembly.
- **OPEN** S1.
- **RAISE** or **LOWER** until the rear of the ramp is level with the front.
- Check the level of the Left Ramp Assembly.
- **CLOSE** S1 and **OPEN** S2.

- **RAISE** or **LOWER** until the rear of the ramp is level with the front.
- **CLOSE all valves.**
- Proceed to STEP FIVE.

STEP FIVE - Leveling - Levelling Ramps

- Measure the height of each ramp.
- **OPEN** either S3 (Right Ramp) or S4 (Left Ramp), whichever is higher.
- **LOWER** until the ramps are at the same height.
- **CLOSE all valves.**
- **OPEN** the MAIN valve and **LOWER** the lift to the ground.
- Proceed to STEP SIX.

STEP SIX - Leveling - Final Height and Equalization Check

- **RAISE** lift to full height and **LOWER** to the ground four times.
- Check the height and level of each ramp and compare to the measurement in Step 5.

The optimum variance between corners is ½” or less.

NOTE: If all current processes have failed to equalize the lift, consult the troubleshooting guide on the following page. If troubleshooting options still fail, repeat process from the beginning.

If the lift is equalized, close the console doors and proceed to the Operation section.

STEP SEVEN - Final Check

1. Run the lift up and down a few times to be sure that the locks are engaging uniformly and that the safety release mechanisms are functioning properly. Re-adjust if necessary.
2. Drive a vehicle onto the lift making sure to set the emergency brake before exiting the vehicle.
3. Cycle the lift up and down two times with a vehicle loaded on the ramps to ensure that the locks are engaging uniformly and that the safety release mechanisms are functioning properly. Re-adjust if necessary.

POST INSTALLATION CHECKLIST

- ▶ Ramp Assemblies Properly Shimmed And Stable
- ▶ Anchor Bolts Tightened
- ▶ Pivot Pins Properly Secure
- ▶ Electric Power Supply Confirmed
- ▶ Equalizing Procedure Complete
- ▶ Safety Locks Functioning Properly
- ▶ Check For Hydraulic Leaks
- ▶ Lubrication of Critical Components
- ▶ All Screws, Bolts, and Pins Secured
- ▶ Operation and Safety Manuals On Site
- ▶ Perform an Operational Test With a Typical Vehicle

Equalization/Leveling Troubleshooting Guide

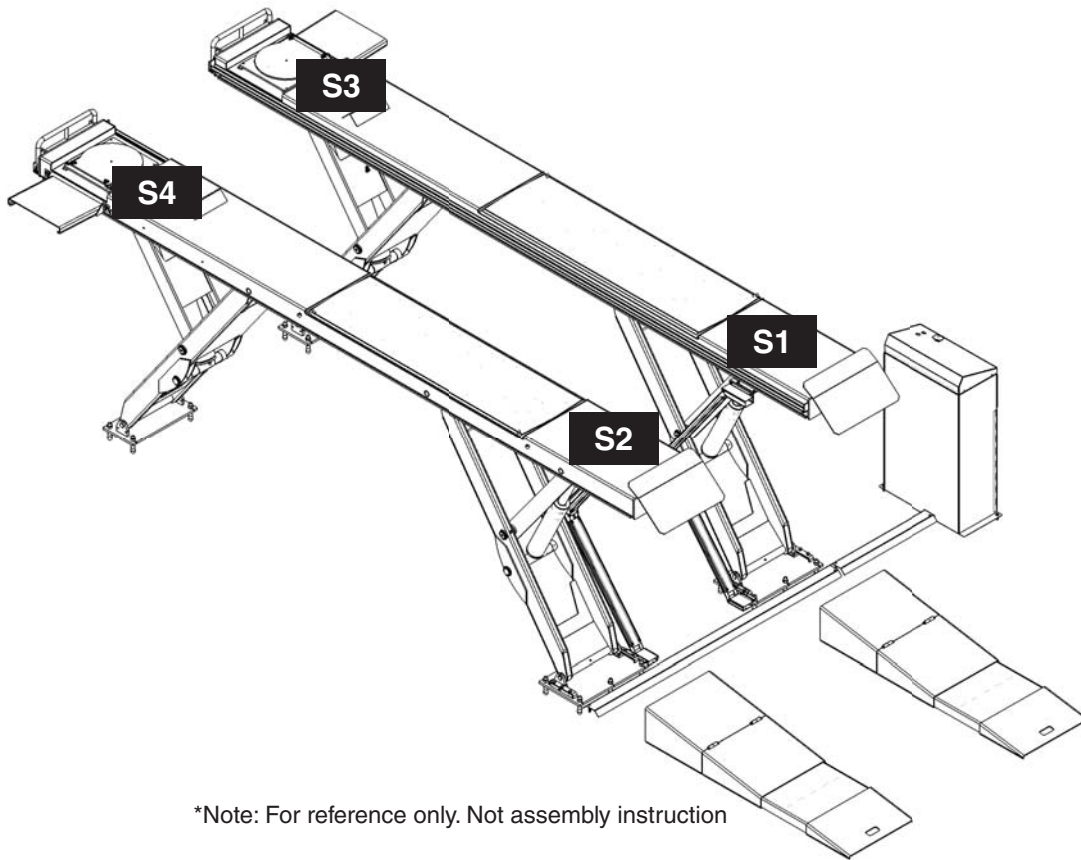

*Note: For reference only. Not assembly instruction

Corners S3 and S4 are unequal with S1 and S2 during lifting

- Open MAIN valve. All other valves should be closed.
- Press the LOWER button on the power console until both ramps are at a convenient height for checking level.
- Close MAIN valve. All other valves should be closed.
- Check the level of the Right Ramp Assembly.
- **OPEN** S1.
- RAISE or LOWER until the rear of the ramp is level with the front.
- Check the level of the Left Ramp Assembly.
- **CLOSE** S1 and **OPEN** S2.
- RAISE or LOWER until the rear of the ramp is level with the front.
- **CLOSE all valves.**

Corners S1 and S2 are out of level at full rise

- Open MAIN valve. All other valves should be closed.

- Press the LOWER button on the power console until both ramps are at a convenient height for checking level.
- Close MAIN valve. All other valves should be closed.
- Check the level of the Right Ramp Assembly.
- **OPEN** S1.
- RAISE or LOWER until the rear of the ramp is level with the front.
- Check the level of the Left Ramp Assembly.
- **CLOSE** S1 and **OPEN** S2.
- RAISE or LOWER until the rear of the ramp is level with the front.
- **CLOSE all valves.**

Master console cylinders are out of synch with lifting cylinders

Lift will not lower completely

- Lower the lift as far as possible.
- **CLOSE** MAIN valve.

- **OPEN** valves S3 and S4.
- Press the LOWER button until both ramps lower to the floor.
- **CLOSE** valves S3 and S4.
- **OPEN** MAIN valve

Lift will not raise completely

Lower the lift until it reaches floor level.

- **CLOSE** MAIN valve.
- **OPEN** valves S3 and S4.
- Press the RAISE button until lift approximately 24"
- **CLOSE** valves S3 and S4.
- **OPEN** MAIN valve
- Press the LOWER button until the ramps are lowered to the floor.
- Close the MAIN valve
- Open S3 and S4 valves
- Press the RAISE Button until the lift approximately 24" above the floor.
-
- Close the S3 and S4 Valves
- Open the MAIN Valve
- Press the LOWER button until the ramps are lowered to the floor.
- Repeat until the ramps cannot be lowered to the floor.
- Close the MAIN valve.
- Open S3 and S4 valves.
- Press the LOWER button until the ramps are lowered to the floor.
- Close the S3 and S4 valves.
- Open the main valve.

After Bleeding and Leveling the Baseplates have moved out of position

- **Reposition the Baseplates to the correct positions before installing anchor bolts.**
- **If a component has been replaced. Bleeding and Leveling must be repeated with the hydraulic system partially filled with fluid.**
- **Call customer service immediately. The complexity of different situations requires Bendpak experts to assist you in correctly bringing your lift back to working condition.**

OVER PRESSURE:

NOTE: Avoid pressing the raise button if the lift is in the maximum raised position. The sound of the motor will change in this situation. If the lift has been raised and the "raise" button has continued to be pressed, press the "lower" button for 1 second to relive system pressure.

STEP 15 (Operation)

To Raise Lift:

1. Position vehicle tires in the center of each Runway.
2. Set parking brake and use Wheel Chocks to hold vehicle in position. (See Fig. 15.1)

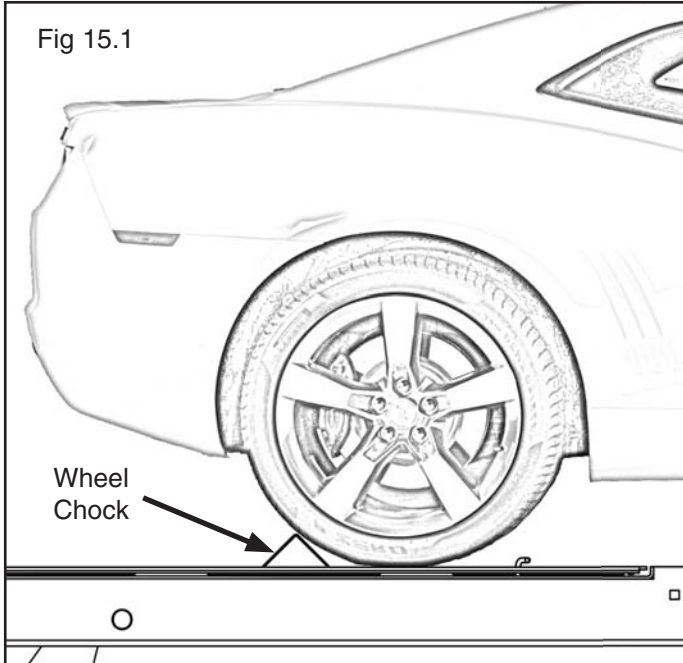

3. Before raising vehicle, be sure all personnel are clear of the lift and surrounding area. Pay careful attention to overhead clearances.
4. Raise the lift to the desired height by pressing the UP button on the power console.
5. After vehicle is raised to the desired height, lower the lift onto the nearest safety lock. ALWAYS MAKE SURE THAT ALL SAFETY LOCKS ARE ENGAGED before entering work area. (See Fig. 15.2)

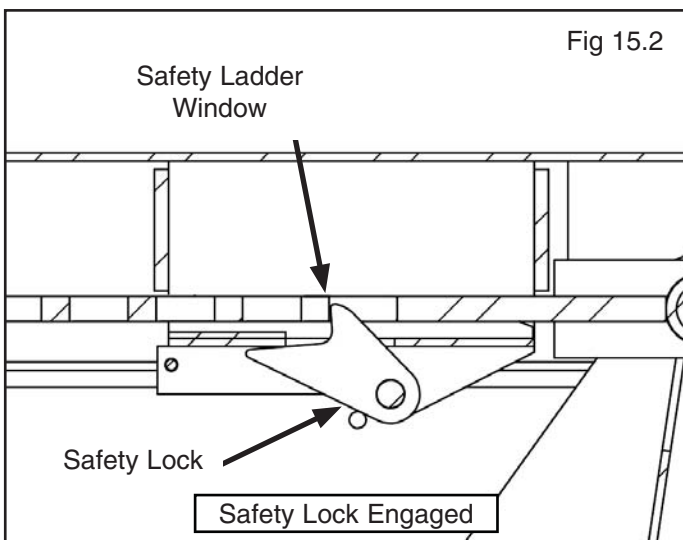

! DANGER

DANGER!

WHEN LOWERING THE LIFT PAY CLOSE ATTENTION THAT ALL PERSONNEL AND OBJECTS ARE KEPT CLEAR. ALWAYS KEEP A VISUAL LINE OF SIGHT ON THE LIFT AT ALL TIMES. ALWAYS MAKE SURE THAT ALL LOCKS ARE DISENGAGED. IF A SAFETY LOCK ENGAGES INADVERTENTLY UPON DESCENT, THE LIFT MAY MALFUNCTION CAUSING THE LOADED VEHICLE TO SHIFT UNDESIRABLY AND MAY CAUSE PERSONAL INJURY AND/OR DEATH.

To Lower Lift:

1. Before lowering vehicle, be sure all personnel are clear of the lift and surrounding area. Pay careful attention to overhead clearances. Be sure that all tools and equipment have been cleared from under the lift.
2. Raise the lift off of the Safety Locks by pressing the push button on the Power Console. Make sure the lift is raised by at least two inches to allow adequate clearance for the locks to clear.
3. Press the Push Button Air Safety Valve and HOLD. The safeties will disengage. (See Fig. 15.3)

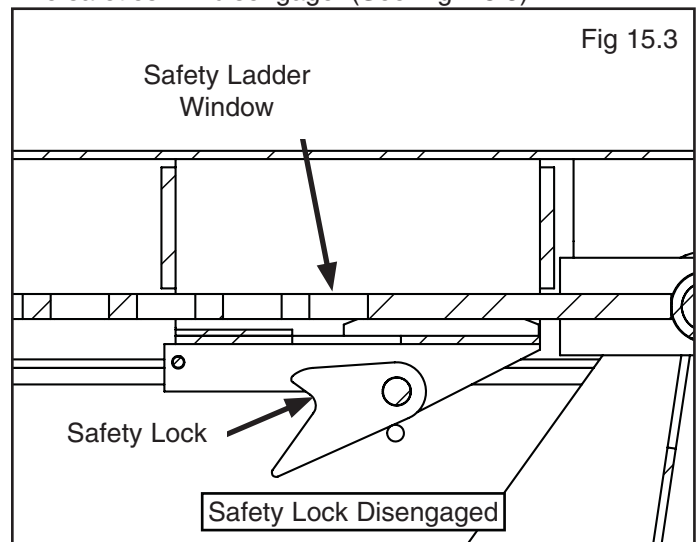

4. Push the LOWERING BUTTON on the Power Unit Console until the lift has descended to the desired height and release the Push Button Air Safety Valve.

STEP 16 *ALIGNMENT MODELS ONLY (Turnplate Pocket Adjustment)

1. After the lift installation, operation check and leveling of the lift has been completed.
2. Lower the lift onto the safeties at a convenient height.
3. Adjust the Turnplate pockets to level using the six adjustment bolts. (See Fig. 16.1)

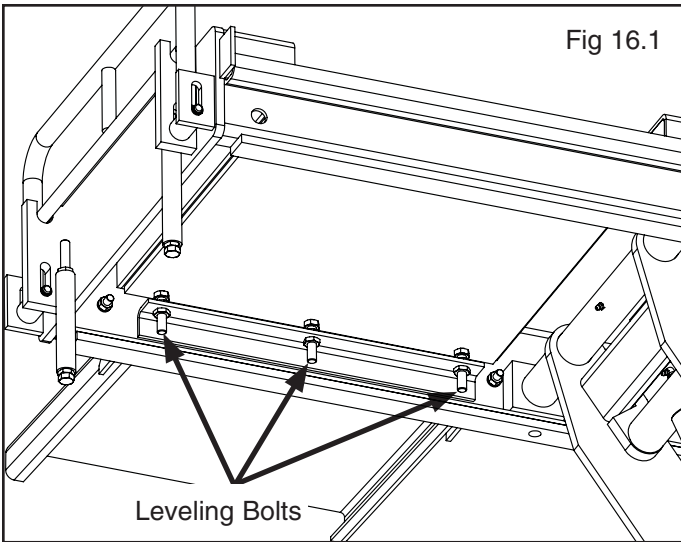

STEP 17 (Work Step Installation)

1. Install the Step Anchors in the desired locations on the ramp assemblies using the provided M10 hardware. (See Fig 17.1)

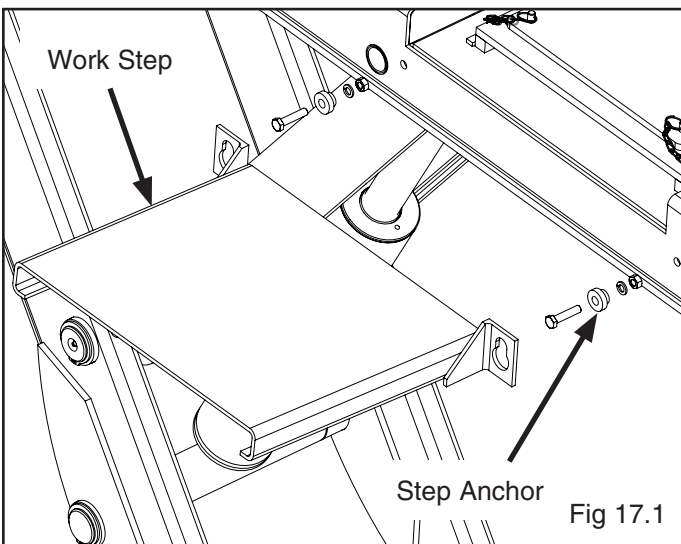

2. Align the Step Anchors with the keyhole slots on the Work Step. Fit the keyhole slots over the Step Anchors and drop the step into place.
3. To remove the Work Step, push the Work Step upwards so that the keyhole slots will be able to fit over the Step Anchors and pull the Work Step away from the ramp. Leave the Step Anchors in place for ease of installation of the Work Step for the next use.
4. To re-install, repeat Step 17 Item 2.



DANGER!
PRIOR TO WORKING UNDERNEATH THE LIFT,
MAKE CERTAIN SAFETY LOCKS ARE ENGAGED TO
PREVENT LIFT FROM UNEXPECTEDLY LOWERING

STEP 18 (Hose Cover Installation)

1. Raise ramps to provide ease of installation for this step.



CAUTION!
BE AWARE OF RAMP POSITION AND PARTS
PROTRUDING FROM RAMPS. INATTENTIVENESS
MAY RESULT IN PERSONAL INJURY.

2. Check fitment of the two floor troughs by placing them over the hose bundles. The Under Ramp Floor Trough should be placed under the ramps, with the cutouts facing the base plates as the hoses from the ramps are routed through them. The shorter Floor Trough should be placed in between the Under Ramp Floor Trough and the Power Unit Console.
3. Once the two troughs are in place, use the Under Ramp Floor Trough as a template, mark the four mounting holes on the concrete underneath with chalk or crayon and set aside the floor troughs.
4. Drill four holes at the locations marked with a 5/16" drill to a depth of 1-1/2". (See Fig 20.1) Pay attention to hose positions. DO NOT damage or pierce the hydraulic or pneumatic hoses.

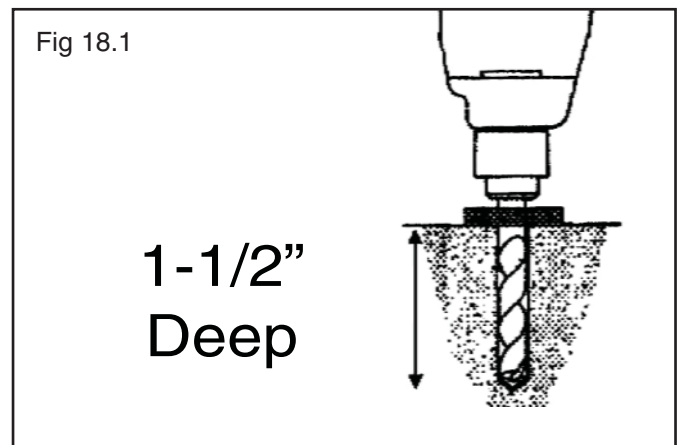

5. After drilling remove dust thoroughly, insert four plastic concrete anchors in to the holes that were drilled.
6. Replace the floor troughs so that the anchors line up with the mounting holes on the two floor troughs. Install four M5 Pan Head sheet metal screws to fasten the floor troughs to the concrete.

STEP 19 (Operation Instructions)

OWNER/EMPLOYER RESPONSIBILITIES

The Owner/Employer:

- Shall ensure that lift operators are qualified and that they are trained in the safe use and operation of the lift using the manufacturer's operating instructions; ALI/SM01-1, ALI Lifting it Right safety manual; ALI/ST-90 ALI Safety Tips card; ANSI/ALI ALOIM-2000, American National Standard for Automotive Lifts-Safety Requirements for Operation, Inspection and Maintenance; ALI/WL Series, ALI Uniform Warning Label Decals/Placards; and in the case of frame engaging lifts, ALI/LP-GUIDE, Vehicle Lifting Points/Quick Reference Guide for Frame Engaging Lifts.
- Shall establish procedures to periodically inspect the lift in accordance with the lift manufacturer's instructions or ANSI/ALI ALOIM-2000, American National Standard for Automotive Lifts-Safety Requirements for Operation, Inspection and Maintenance; and The Employer shall ensure that lift inspectors are qualified and that they are adequately trained in the inspection of the lift.
- Shall establish procedures to periodically maintain the lift in accordance with the lift manufacturer's instructions or ANSI/ALI ALOIM-2000, American National Standard for Automotive Lifts-Safety Requirements for Operation, Inspection and Maintenance; and The Employer shall ensure that lift maintenance personnel are qualified and that they are adequately trained in the maintenance of the lift.

- Shall maintain the periodic inspection and maintenance records recommended by the manufacturer or ANSI/ALI ALOIM-2000, American National Standard for Automotive Lifts-Safety Requirements for Operation, Inspection and Maintenance.
- Shall display the lift manufacturer's operating instructions; ALI/SM 93-1, ALI Lifting It Right safety manual; ALI/ST-90 ALI Safety Tips card; ANSI/ALI ALOIM-2000, American National Standard for Automotive Lifts-Safety Requirements for Operation, Inspection and Maintenance; and in the case of frame engaging lifts, ALI/LP-GUIDE, Vehicle Lifting Points/Quick Reference Guide for Frame Engaging Lifts; in a conspicuous location in the lift area convenient to the operator.
- Shall provide necessary lockout/tagout means for energy sources per ANSI Z244.1-1982 (R1993), Safety Requirements for the Lockout/Tagout of Energy Sources, before beginning any lift repairs.
- Shall not modify the lift in any manner without the prior written consent of the manufacturer.



Safe Lift Operation

Automotive and truck lifts are critical to the operation and profitability of your business. The safe use of this and other lifts in your shop is critical in preventing employee injuries and damage to customer's vehicles. By operating lifts safely you can ensure that your shop is profitable, productive and safe.

Safe operation of automotive lifts requires that only trained employees should be allowed to use the lift.

TRAINING SHOULD INCLUDE, BUT NOT LIMITED TO:

- ◆ Proper positioning of the vehicle on the runway. (See manufacturers minimize wheel base loading requirements.)
- ◆ Use of the operating controls.
- ◆ Understanding the lift capacity.
- ◆ Proper use of jack stands or other load supporting devices.

- ◆ Proper use, understanding and visual identification of safety lock devices and their operation.
- ◆ Reviewing the safety rules.
- ◆ Proper housekeeping procedures (lift area should be free of grease, oil, tools, equipment, trash, and other debris)
- ◆ A daily inspection of the lift should be completed prior to its use. Safety devices, operating controls, lift arms and other critical parts should be inspected prior to using the lift.
- ◆ All maintenance and repairs of the lift should be completed by following the manufacturer's requirements. Lift repair parts should meet or exceed OEM specifications. Repairs should only be completed by a qualified lift technician.
- ◆ The vehicle manufacturer's recommendations should be used for spotting and lifting the vehicle.

Safe Lift Operation (Cont'd)

LIFT OPERATION SAFETY

- ◆ It is important that you know the load limit. Be careful that you do not overload the lift. If you are unsure what the load limit is, check the data plate found on one of the lift columns or contact the manufacturer.
- ◆ The center of gravity should be followed closely to what the manufacturer recommends.
- ◆ Always make sure you have proper overhead clearance. Additionally, check that attachments, (vehicle signs, campers antennas, etc) are not in the way.
- ◆ Be sure that prior to the vehicle being raised, the doors, trunk, and hood are closed securely
- ◆ Prior to being raised, make sure there is no one standing closer than six feet from the lift
- ◆ After positioning the vehicle on the lift runways, set the emergency brake, make sure the ignition is off, the doors are closed, overhead obstructions are cleared, and the transmission is in neutral.
- ◆ Double check that the automatic chock devices are in position and then when the lift is raised, observe the chocks.
- ◆ Put pads or adapters in the right position under the contact points that have been recommended
- ◆ The lift should be raised just until the vehicle's wheels are about one foot off the ground. If contact with the vehicle is uneven or it appears that the vehicle is not sitting secure, carefully lower the lift and readjust.
- ◆ Always consider potential problems that might cause a vehicle to slip, i.e., heavy cargo, undercoating, etc.
- ◆ Pay attention when walking under a vehicle that is up on the hydraulic lift.



- ◆ **DO NOT** leave the controls while the lift is still in motion.
- ◆ **DO NOT** stand directly in front of the vehicle or in the bay when vehicle is being loaded or driven into position.
- ◆ **DO NOT** Go near vehicle or attempt to work on the vehicle when being raised or lowered.
- ◆ **REMAIN CLEAR** of lift when raising or lowering vehicle.
- ◆ **DO NOT** rock the vehicle while on the lift or remove any heavy component from vehicle that may cause exces-

sive weight shift.

- ◆ **DO NOT** lower the vehicle until people, materials, and tools are clear
- ◆ **ALWAYS ENSURE** that the safeties are engaged and lowered on to the safety locks before any attempt is made to work on or near vehicle.
- ◆ Some vehicle maintenance and repair activities may cause the vehicle to shift. Follow the manufacturer's guidelines when performing these operations. The use of jack stands or alternate lift points may be required when completing some repairs.
- ◆ **READ AND UNDERSTAND** all safety warning procedures before operating lift.
- ◆ **KEEP HANDS AND FEET CLEAR.** Remove hands and feet from any moving parts. Keep feet clear of lift when lowering. Avoid pinch points.
- ◆ **ONLY TRAINED OPERATORS** should operate this lift. All non-trained personnel should be kept away from work area. Never let non-trained personnel come in contact with, or operate lift.
- ◆ **USE LIFT CORRECTLY.** Use lift in the proper manner. Never use lifting adapters other than what is approved by the manufacturer.
- ◆ **DO NOT** override self-closing lift controls.
- ◆ **CLEAR AREA** if vehicle is on danger of falling.
- ◆ **STAY ALERT.** Watch what you are doing. Use common sense. Be aware.
- ◆ **CHECK FOR DAMAGED PARTS.** Check for alignment of moving parts, breakage of parts or any condition that may affect its operation. Do not use lift if any component is broken or damaged.
- ◆ **NEVER** remove safety related components from the lift. Do not use lift if safety related components are damaged or missing.
- ◆ When the lift is being lowered, make sure everyone is standing at least six feet away.
- ◆ Be sure there are no jacks, tools, equipment, left under the lift before lowering.
- ◆ Always lower the vehicle down slowly and smoothly.

MAINTENANCE INSTRUCTIONS

WEEKLY MAINTENANCE

1. Lubricate all pivot pins with general purpose grease at specified locations found on page 34.
2. Check all component connections, bolts and pins to ensure proper mounting.
3. Lubricate safety lock pivot points and Safety Ladder Adjustment Rods with general purpose light spray-oil.

MONTHLY MAINTENANCE

1. Check safety locks to ensure they are in good operating condition.
2. Check all hoses for excessive signs of wear.
3. Make a visual inspection of ALL MOVING PARTS and check for excessive signs of wear.
4. Replace ALL FAULTY PARTS before lift is put back into operation.



- ◆ **NEVER EXCEED THE RATED CAPACITY** of lift.
- ◆ **DO NOT USE LIFT** if any component is found to be defective or worn.
- ◆ **NEVER OPERATE LIFT** with any person or equipment below.
- ◆ **ALWAYS STAND CLEAR** of lift when lowering or raising.
- ◆ **ALWAYS INSURE SAFETY LOCKS ARE ENGAGED** before entering work area.
- ◆ **NEVER LEAVE LIFT IN ELEVATED CONDITION** unless all safety locks are engaged.
- ◆ Refer to ANSI/ALI ALOIM booklet for periodic inspection checklist and maintenance log sheet.

DANGER

THE MAXIMUM LIFTING CAPACITY FOR THIS LIFT IS DESCRIBED BELOW

Maximum Lifting Capacity

12,000 lbs. / 5443 kg

Max. Lifting Cap. / Front of Lift Center

6000 lbs. / 2722 kg

Max. Lifting Cap. / Rear of Lift Center

6000 lbs. / 2722 kg

Exceeding the weight capacity of this lift can damage lift and/or property and may cause personal harm, injury or death to operators and/or bystanders. All vehicles MUST be positioned on lift with CENTER OF GRAVITY midway between adapters and/or centered on runways. Damage to lift due to overloading or misuse IS NOT covered under warranty.

SAFETY INSTRUCTIONS



Read operating and safety manuals before using lift.

SAFETY INSTRUCTIONS



Proper maintenance and inspection is necessary for safe operation.

SAFETY INSTRUCTIONS



Do not operate a damaged lift.

The messages and pictographs shown are generic in nature and are meant to generally represent hazards common to all automotive lifts regardless of specific style.

Funding for the development and validation of these labels was provided by the Automotive Lift Institute, PO Box 33116 Indialantic, FL. 32903.

They are protected by copyright. Set of labels may be obtained from ALI or its member companies.

© 1992 by ALI, Inc.

ALI/WL200a

WARNING



Clear area if vehicle is in danger of falling.

WARNING



Remain clear of lift when raising or lowering vehicle.

WARNING



Keep clear of pinch points when lift is moving.

WARNING

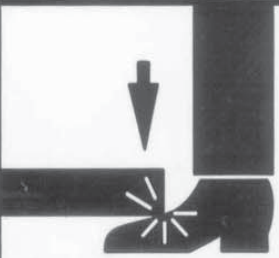

Keep feet clear of lift while lowering.

CAUTION



Lift to be used by trained operator ONLY.

CAUTION



Authorized personnel only in lift area.

WARNING



Do not override self-closing lift controls.

WARNING

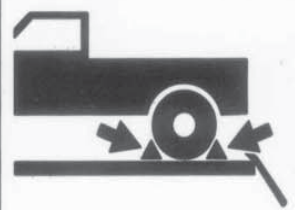

Chock wheel to prevent vehicle movement.

The messages and pictographs shown are generic in nature and are meant to generally represent hazards common to all automotive lifts regardless of specific style.

Funding for the development and validation of these labels was provided by the Automotive Lift Institute, PO Box 33116 Indialantic, FL. 32903.

They are protected by copyright. Set of labels may be obtained from ALI or its member companies.

© 1992 by ALI, Inc.

ALI/WL200c

The messages and pictographs shown are generic in nature and are meant to generally represent hazards common to all automotive lifts regardless of specific style.

Funding for the development and validation of these labels was provided by the Automotive Lift Institute, PO Box 33116 Indialantic, FL. 32903.

They are protected by copyright. Set of labels may be obtained from ALI or its member companies.

© 1992 by ALI, Inc.

ALI/WL200w

LIFT WILL NOT RAISE

POSSIBLE CAUSE

1. Air in oil, (1,2,7,12)
2. Cylinder binding, (8)
3. Cylinder leaks internally, (8)
4. Motor run backward under pressure, (10)
5. Lowering valve leaks, (3,4,9,10)
6. Motor runs backwards, (6,13,10)
7. Pump damaged, (9,10)
8. Pump won't prime, (1,3,7,9,10,11,12,13)
9. Relief valve leaks, (9,10)
10. Voltage to motor incorrect, (6,10,13)
11. Valves not closed fully or correctly (14)

REMEDY

- | REMEDY | INSTRUCTION |
|---|--|
| 1. Check for proper oil level. | The oil level should be up to the bleed screw in the reservoir with the lift all the way down. |
| 2. Bleed cylinders. | See Installation Manual |
| 3. Flush release valve to get rid of possible contamination | Simultaneously hold the lower button and the raise button allowing unit to run for 15 seconds. |
| 4. Dirty oil. | Replace oil with clean AW32 hydraulic oil. |
| 5. Tighten all fasteners. | Tighten fasteners to recommended torques. |
| 6. Check if motor is wired correctly. | .Compare wiring of motor to electrical diagram on drawing. |
| 7. Oil seal damaged or cocked | Replace oil seal around pump shaft. |
| 8. See Installation Manual | Contact BendPak Customer Support. |
| 9. Replace with new part | .Replace with new part. |
| 10. Return unit for repair | Return unit for repair. |
| 11. Check pump-mounting bolts | Bolts should be 15 to 18 ft. lbs. |
| 12. Inlet screen clogged | .Clean inlet screen or replace. |
| 13. Check wall outlet voltages and wiring | Make sure unit and wall outlet are wired properly. |
| 14. Check all valves inside console | .Make sure ALL valves are fully in the CLOSED position except for the MAIN valve. |

MOTOR WILL NOT RUN

POSSIBLE CAUSE

1. Fuse blown, (5,2,1,3,4)
2. Microswitch burned out, (1,2,3,4)
3. Motor burned out, (1,2,3,4,6)
4. Voltage to motor incorrect, (2,1,8)

REMEDY

- | REMEDY | INSTRUCTION |
|---|---|
| 1. Check for correct voltage | Compare supply voltage with voltage on motor name tag. Check that the wire is sized correctly. N.E.C. table 310-12 requires AWG 10 for 25 Amps. |
| 2. Check motor is wired correctly | Compare wiring of motor to electrical diagram on drawing. |
| 3. Don't use extension cords | According to N.E.C. : " The size of the conductors... should be such that the voltage drop would not exceed 3% to the farthest outlet for power..." Do not run motor at 115 VAC – damage to the motor will occur. |
| 4. Replace with new part | Replace with new part. |
| 5. Reset circuit breaker/fuse | Reset circuit breaker/fuse. |
| 6. Return unit for repair | Return unit for repair. |
| 7. See Installation Manual | See Installation Manual. |
| 8. Check wall outlet voltage and wiring | Make sure unit and wall outlet is wired properly. Motor must run at 208/230 VAC. |

INSTRUCTION

LIFT WILL NOT STAY UP

POSSIBLE CAUSE

1. Air in oil, (1,2,3)
2. Check valve leaks, (6)
3. Cylinders leak internally, (7)
4. Lowering valve leaks, (4,5,1,7,6)
5. Leaking fittings, (8)

REMEDY

- | REMEDY | INSTRUCTION |
|---|--|
| 1. Check oil level | The oil level should be up to the bleed screw in the reservoir with the lift all the way down. |
| 2. Oil seal damaged and cocked | Replace oil seal around pump shaft. |
| 3. Bleed cylinder | Refer to Installation Manual. |
| 4. Flush release valve | Simultaneously hold the lower button and the raise button allowing unit to run for 15 seconds. |
| 5. Replace with new valve | Replace with new valve. |
| 6. Return unit for repair | Return unit for repair. |
| 7. See Installation Manual | Contact BendPak Customer Support. |
| 8. Check complete hydraulic system for leaks. | Tighten all hydraulics fittings and inspects all hoses. |

INSTRUCTION

WILL NOT RAISE LOADED LIFT

POSSIBLE CAUSE

1. Air in oil, (1,2,3,4)
2. Cylinder binding, (5)
3. Cylinder leaks internally, (5)
4. Lift overloaded, (6,5)
5. Lowering valve leaks, (7,8,1,5,9)
6. Motor runs backwards, (10,12,9)
7. Pump damaged, (5,9)
8. Pump won't prime, (1,2,3,4,5,11,9)
9. Relief valve leaks, (8,5,9)
10. Voltage to motor incorrect, (10,12,5)

REMEDY

- | REMEDY | INSTRUCTION |
|--|--|
| 1. Check oil level | The oil level should be up to the bleed screw in the reservoir with the lift all the way down. |
| 2. Check/Tighten inlet tubes | Replace inlet hose assembly. |
| 3. Oil seal damaged or cocked | Replace oil seal and install. |
| 4. Bleed cylinders | See Installation Manual. |
| 5. See Installation Manual | Contact BendPak Customer Support. |
| 6. Check vehicle weight | Compare weight of vehicle to weight limit of the lift. |
| 7. Flush release valve | Simultaneously hold the lower button and the raise button allowing unit to run for 15 seconds. |
| 8. Replace with new part | Replace with new part. |
| 9. Return unit for repair | Return unit for repair. |
| 10. Check motor is wired correctly | Compare wiring of motor to electrical diagram on power unit drawing. |
| 11. Inlet screen clogged | Clean inlet screen or replace. |
| 12. Check wall outlet voltage and wiring | Make sure unit and wall outlet is wired properly. |

LIFT LOWERS SLOWLY OR NOT AT ALL

POSSIBLE CAUSE

1. Cylinders binding, (1)
2. Release valve clogged, (5,4,2,3)
3. Pressure fitting too long, (6)

REMEDY

- | REMEDY | INSTRUCTION |
|---|--|
| 1. See Installation Manual | Contact BendPak Customer Support. |
| 2. Replace with new part | Replace with new part. |
| 3. Return for repair | Return for repair. |
| 4. Check oil. | Use clean AW32 hydraulic oil only. If oil is contaminated, replace with clean hydraulic oil and flush entire system. |
| 5. Clean release valve | Wash release valve in solvent and blow out with air. |
| 6. Replace fitting with short thread lead | Replace fitting with short thread lead. |

INSTRUCTION

IMPORTANT



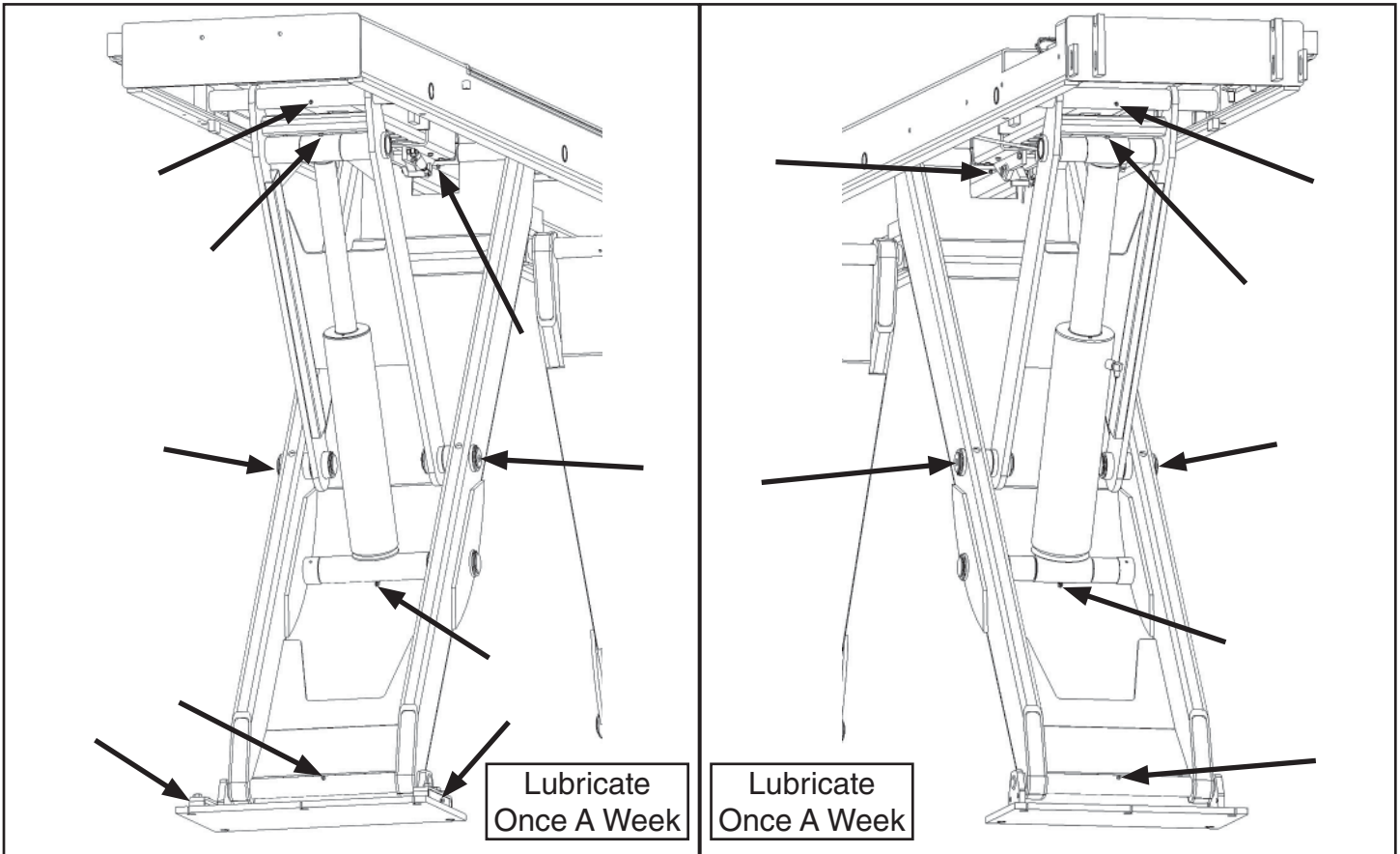

If vehicle becomes stranded in the air, follow all operation instructions as shown on pages 25 and preceding Troubleshooting sections. If after observing that all mechanical locks are released and the lift still fails move following all standard operating procedures, immediately stop using the lift and contact factory or factory approved service center for further instructions.

Grease Port / Lubrication Locations (Both Ramps)



Torque Recommendations

VALUES ARE STATED IN FOOT POUNDS (ft-lb)

					
		SAE 0-1-2 CLASS 4.8	SAE Grade 5 CLASS 8.8	SAE Grade 8 CLASS 10.9	SOCKET HEAD CAP SCREW CLASS 12.9
Bolt Size (SAE)	Bolt Size (Metric)				
1/4-20	M6 x 1.0	6	10	14	13
5/16-18	M8 x 1.25	12	19	29	31.4
3/8-16	M10 x 1.50	20	33	47	62
7/16-14		32	54	78	
1/2-13	M12 x 1.75	47	78	119	108
9/16-12	M14 x 2.00	69	114	169	173
5/8-11	M16 x 2.00	96	154	230	269
3/4-10	M18 x 2.50	155	257	380	372
7/8-9	M22 x 2.50	206	382	600	716
3/4 Anchor Bolts		75 MIN 110 MAX			

INSTALLATION FORM

Customer Name:		Date of Installation:
Company Name:		
Street Address:		
City:	State:	Zip:
Phone:	Fax:	

Pre-Install Agreement

I, (the undersigned) acting as the owner of the business listed above assume responsibility for any permits required, either state or county mandated, related to the installation and/or operation of this equipment. I assume responsibility for the concrete floor and condition thereof, now or later, where the above equipment model(s) are installed. I will assume all liability for losses, damages (including loss of use), expenses, demands, claims, and judgments in connection with or arising out of any personal injury or alleged damage to property, sustained or alleged to have been sustained in connection with, or to have arisen out of the condition and/or drilling of the concrete near or adjacent to the equipment model(s) listed above. If my employee(s) offer assistance of any kind during installation of the above equipment model(s) I hold the manufacturer and installation company harmless of all liability for losses, damages, expenses, claims, and judgments in connection with or arising out of any personal injury or alleged damage to property, sustained or alleged to have been sustained in connection with the installation of the above equipment model(s).

I understand that the lifts above are supplied with concrete fasteners meeting the criteria of the American National Standard "Automotive Lifts - Safety Requirements for Construction, Testing, and Validation" ANSI/ALI ALCTV-1998, and that I will be responsible for all charges related to any special regional structural and/or seismic anchoring requirements specified by any other agencies and/or codes such as the Uniform Building Code (UBC) and/or International Building Code (IBC).

Customer Signature: _____ Print Name: _____ Date: _____

Post-Installation Check-Off

- | | |
|--|--|
| <input type="checkbox"/> Base and Columns Properly Shimmed And Stable
<input type="checkbox"/> Anchor Bolts Tightened
<input type="checkbox"/> Runways Properly Attached and Secured
<input type="checkbox"/> Electric Power Supply Confirmed
<input type="checkbox"/> Cables / Chains Adjusted Properly
<input type="checkbox"/> Safety Locks Functioning Properly
<input type="checkbox"/> Check For Hydraulic Leaks
<input type="checkbox"/> Oil Level | <input type="checkbox"/> Lubrication of Critical Components
<input type="checkbox"/> Lift Adapters
<input type="checkbox"/> Check For Overhead Obstructions
<input type="checkbox"/> Runways Level
<input type="checkbox"/> All Screws, Bolts, and Pins Secured
<input type="checkbox"/> Surrounding Area and Lift Clean In Appearance
<input type="checkbox"/> Proper Operation, Maintenance and Safety Explained
<input type="checkbox"/> Operation and Safety Manual(s) Left at Site |
|--|--|

I, (the undersigned) confirm that the above installation procedure(s) were completed. I understand that I will be responsible for maintaining this equipment as outlined in the accompanied **Installation and Operation Manual** and **ANSI/ALI ALOIM Safety Requirements for Operation, Inspection and Maintenance**. I understand that personal injury and/or damage to property can occur if the above equipment model(s) are not maintained or used improperly and take full responsibility for training my employees on proper use and maintenance of this equipment. I hold the manufacturer and installation company harmless of all liability for losses, damages (including loss of use), expenses, demands, claims, and judgments in connection with or related to improper use, improper training, or lack of required maintenance. I understand that the warranty does not cover replacement of parts worn or damaged due to normal use or lack of required maintenance

Customer Signature: _____ Print Name: _____ Date: _____

Installer Signature: _____ Print Name: _____ Date: _____

Installer Company Name: _____

Street Address: _____

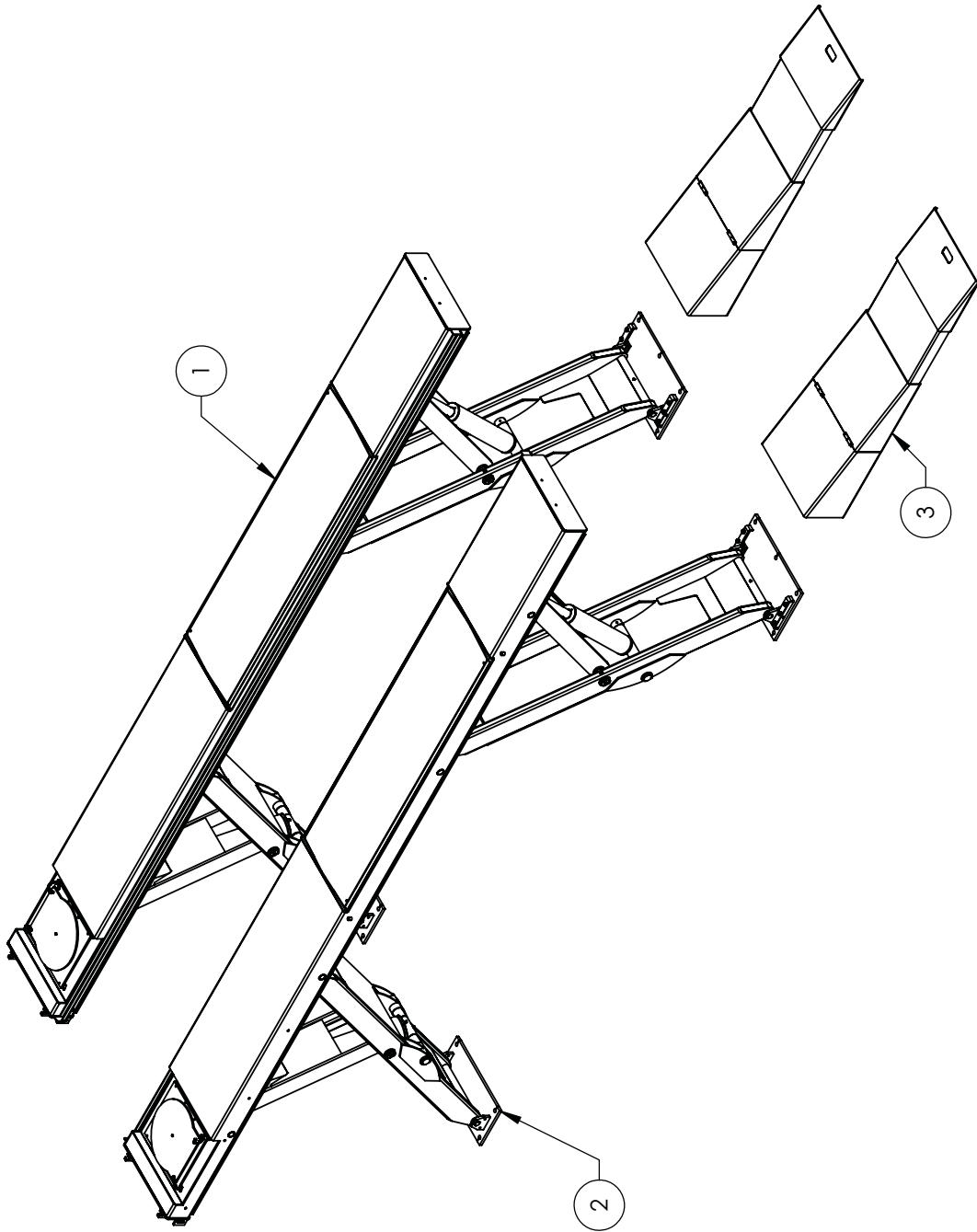

City: _____ State: _____ Zip: _____

Phone: _____ Phone (Other): _____



ITEM NO.	PART NUMBER	DESCRIPTION	QTY	REV
1	52155811	XR-12000A COMPLETE RIGHT RAMP ASSEMBLY	1	B
2	52155821	XR-12000A COMPLETE LEFT RAMP ASSEMBLY	1	B
3	5600438	XR-12 SERIES DRIVE UP RAMP WELDMENT	2	A

DO NOT SCALE DRAWING		NAME	DATE
DIMENSIONS ARE IN MM		TM	01/15/2013
		MM	03/12/2013

			
MATERIAL: ---		TITLE: XR-12000A LIFT SUPERSTRUCTURE	
SIZE: ---		SIZE DWG. NO. A 5245376	

PROPRIETARY AND CONFIDENTIAL THE INFORMATION CONTAINED IN THIS DRAWING IS THE PROPERTY OF BENDPAK INC. ANY REPRODUCTION IN PART OR AS A WHOLE WITHOUT THE WRITTEN PERMISSION OF BENDPAK INC. IS PROHIBITED.		1645 LEMONWOOD DR. BendPak SANTA PAULA, CA 93060 <small>INDUSTRIAL EQUIPMENT DIVISION</small>	
NEXT ASSEMBLY 5260101		SCALE: 1:38 SHEET 1 OF 1	

NOTE: UNLESS OTHERWISE SPECIFIED.
 1. SEE SHIPPING INSTRUCTIONS FOR FINAL PACKAGING

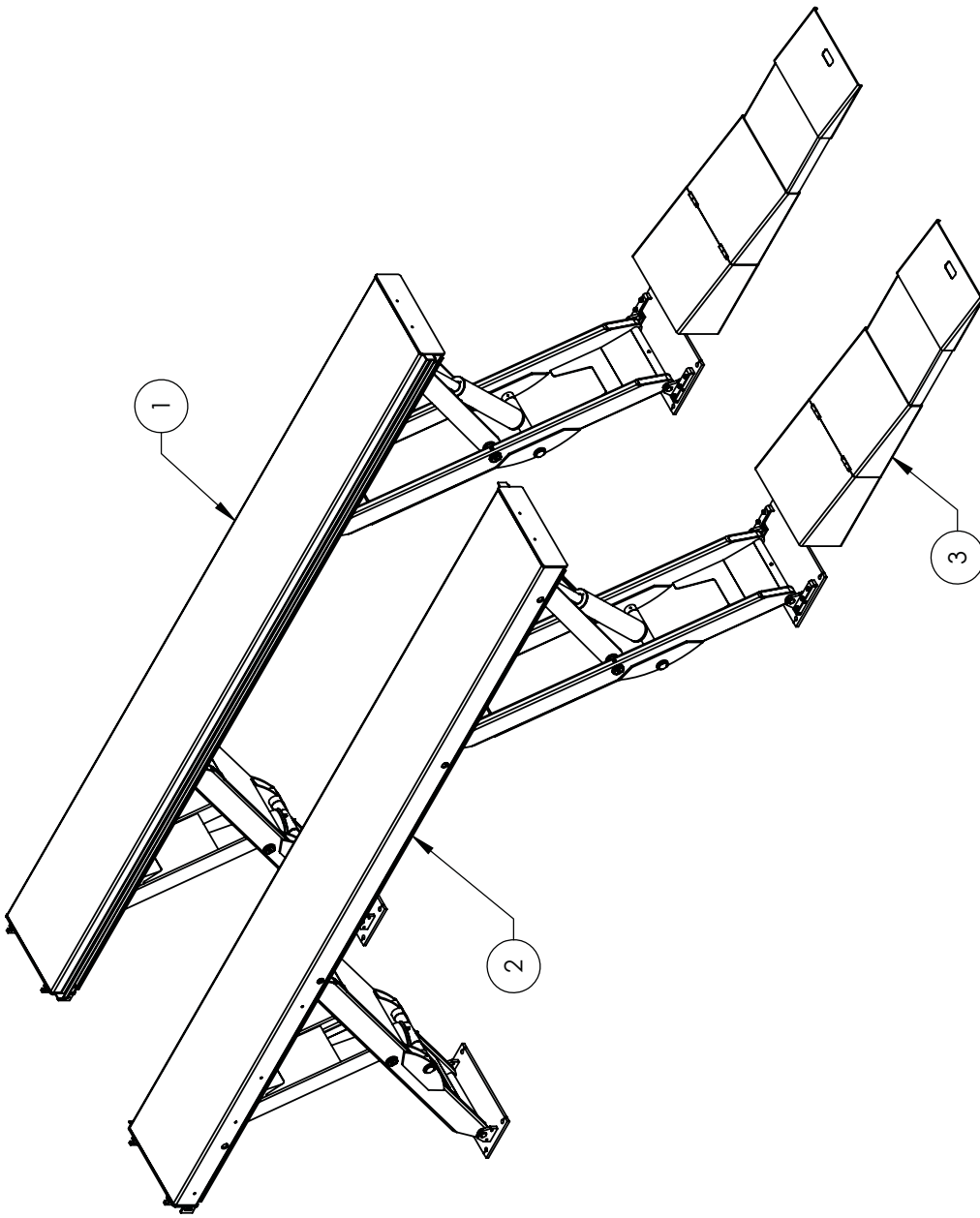

ITEM NO	PART NUMBER	DESCRIPTION	QTY	REV
1	5215585	XR-12000 COMPLETE RIGHT RAMP ASSEMBLY	1	B
2	5215586	XR-12000 COMPLETE LEFT RAMP ASSEMBLY	1	B
3	5600438	XR-12 SERIES DRIVE UP RAMP WEIDMENT	2	A

DO NOT SCALE DRAWING
 DIMENSIONS ARE IN MM

DRAWN TM 01/23/2013
 CHECKED MM 03/12/2013

THIRD ANGLE PROJECTION



TITLE: XR-12000 LIFT SUPERSTRUCTURE

SIZE DWG. NO. A 5245377

REV B

SCALE: 1:38

SHEET 1 OF 1



NOTE: UNLESS OTHERWISE SPECIFIED.
 1. SEE SHIPPING INSTRUCTIONS FOR FINAL PACKAGING

NEXT ASSEMBLY
 5260102

PROPERTY AND CONFIDENTIAL
 THE INFORMATION CONTAINED IN THIS DRAWING IS
 THE PROPERTY OF BENDPAK INC. ANY
 REPRODUCTION IN PART OR AS A WHOLE WITHOUT
 THE WRITTEN PERMISSION OF BENDPAK INC. IS
 PROHIBITED.

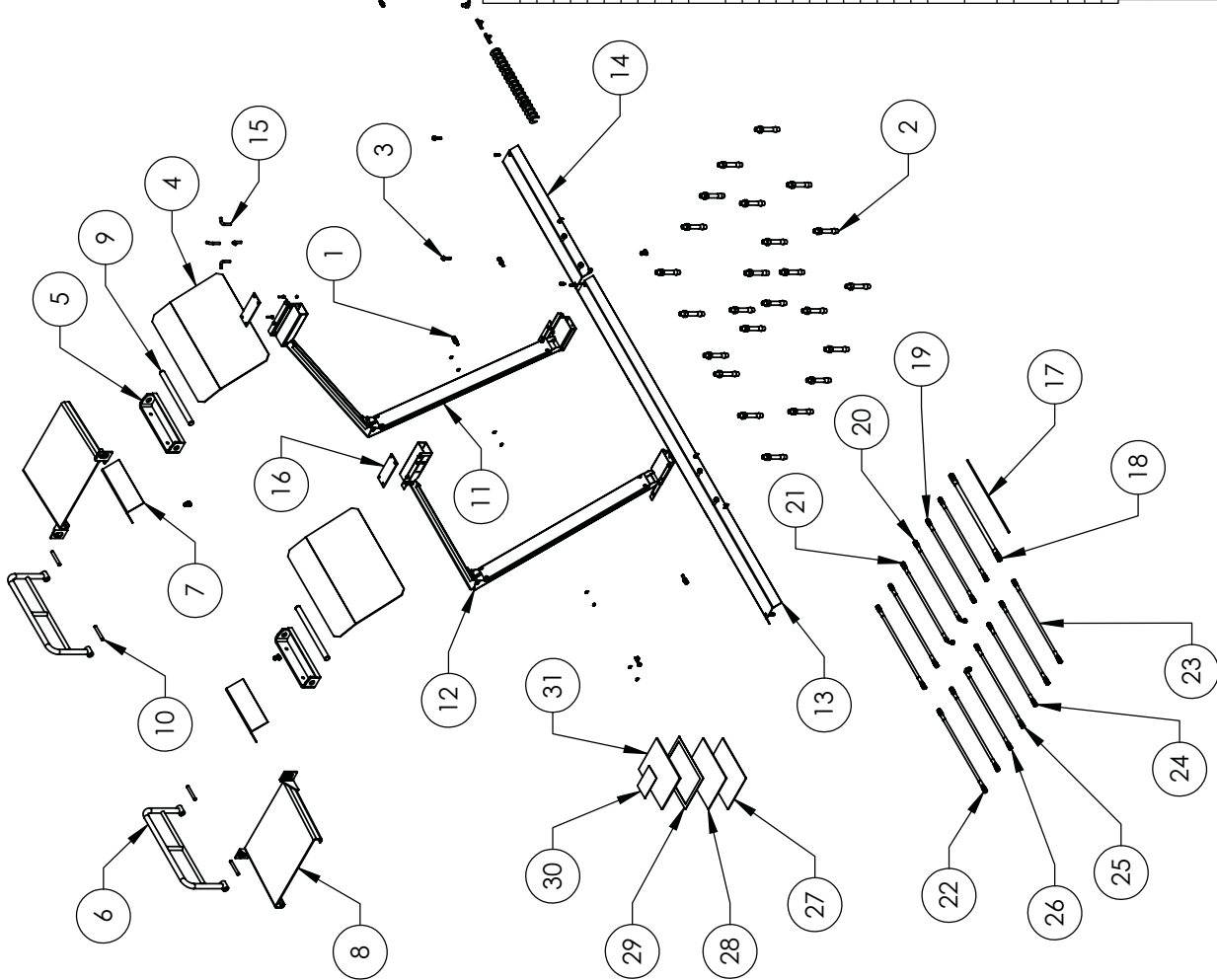

ITEM NO	PART NUMBER	DESCRIPTION	QTY	REV
1	5174680	XR-12000 SERIES PARTS BAG	1	A
2	51730455	AB 3/4" X 4' 3/4" W/II	24	-
3	5300309	AB Ø3.78" X 17.78"	2	-
4	5300307	XR-12 SERIES FLIP UP RAMP WELDMENT	2	B
5	5600437	XR-12 SERIES FLIP UP RAMP BRACKET WELDMENT	2	A
6	5600435	XR-12 SERIES TIRE STOP WELDMENT	2	B
7	5600436	XR-12 SERIES TIRE STOP WELDMENT	2	A
8	5700072	WHEEL CHOCK	2	B
9	5715179	WORK STEP	2	A
10	5746114	XR-12 SERIES FLIP UP RAMP PIN	4	A
11	5746115	XR-12 SERIES TIRE STOP HINGE PIN	4	A
12	5215364	XR-12000 SERIES RIGHT SIDE HOSE TROUGH ASSEMBLY	1	D
13	5215365	XR-12000 SERIES LEFT SIDE HOSE TROUGH ASSEMBLY	1	D
14	5701980	XR-12000 SERIES UNDER RAMP FLOOR TROUGH	1	D
15	5701983	XR-12000 SERIES UNDER RAMP FLOOR TROUGH	1	D
16	5745050	XR-12000 SERIES HOSE TROUGH RAMP CONNECTOR PLATE	4	A
17	5745051	SLIP FLATE LOCK PIN	2	A
18	5570795	1/4" POLY FLO TUBING	197.00mm	-
19	5570796	XR-12000 SERIES HYDRAULIC HOSE ASSY Ø10 x 400mm DS	2	A
20	5570039	XR-12000 SERIES HYDRAULIC HOSE ASSY Ø6.4 x 19.56mm DS	2	C
21	5570032	HOSE ASSEMBLY Ø6.4 x 5000mm	2	C
22	5570905	XR-12000 SERIES HOSE ASSEMBLY Ø6.4 x 6045mm	2	C
23	5570852	XR-12000 SERIES HYDRAULIC HOSE ASSY Ø6.4 x 470mm DS	4	A
24	5570004	XR-12000 SERIES HYDRAULIC HOSE ASSY Ø6.4 x 6147mm DS	2	B
25	5570208	XR-12000 SERIES HYDRAULIC HOSE ASSY Ø6.4 x 11340mm DS	1	A
26	5570205	XR-12000 SERIES HYDRAULIC HOSE ASSY Ø6.4 x 12028mm DS	1	A
27	5570204	XR-12000 SERIES HYDRAULIC HOSE ASSY Ø6.4 x 1100mm SB	1	A
28	5900152	ALIGN OIM OPERATION INSPECTION & MAINTENANCE	1	-
29	5900147	SAFETY MANUAL ALZ SM 93-1	1	-
30	5900151	SAFETY TIPS CARD ALST 90	1	-
31	5900050	BENDPAK #90 WARRANTY CARD	1	-
		XR-12000/12000A INSTALLATION MANUAL	1	-

DO NOT SCALE DRAWING

NAME: _____ DATE: _____

DRAWN: TM 01/21/2013

CHECKED: MM 02/21/2013

THIRD ANGLE PROJECTION

SMILEY FACE

MATERIAL: ----

SIZE: ----

PROPRIETARY AND CONFIDENTIAL
THE INFORMATION CONTAINED IN THIS DRAWING IS THE PROPERTY OF BENDPAK INC. ANY REPRODUCTION IN PART OR AS A WHOLE WITHOUT THE WRITTEN PERMISSION OF BENDPAK INC. IS PROHIBITED.

SCALE: 1:35

SHEET 1 OF 1

NOTE: UNLESS OTHERWISE SPECIFIED, SEE SHIPPING INSTRUCTIONS FOR FINAL PACKAGING

NEXT ASSEMBLY	5260101
5260101	5260102

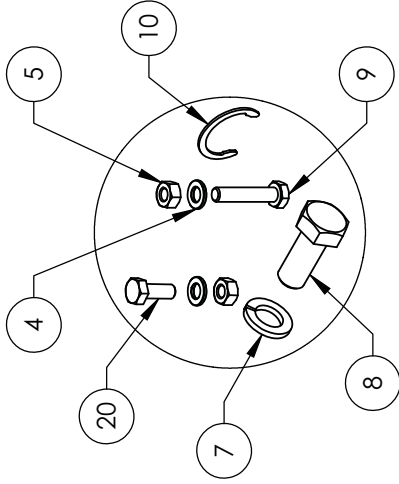
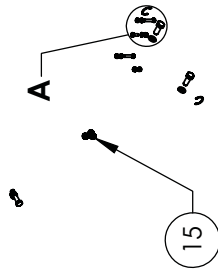
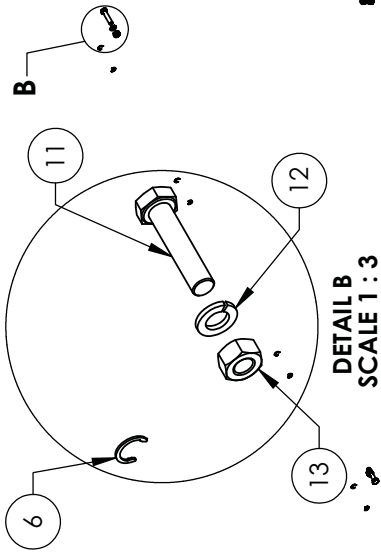

DETAIL A
SCALE 1:3

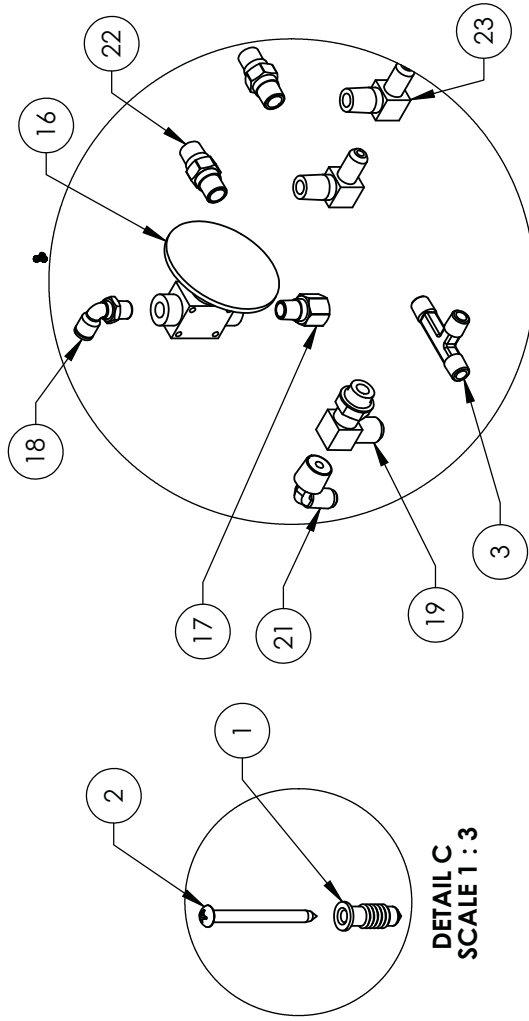
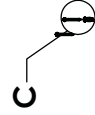
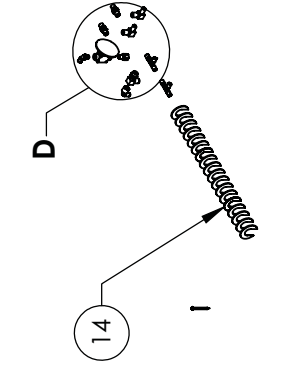

DETAIL C
SCALE 1:3

DETAIL D
SCALE 1:4

ITEM NO	PART NUMBER	DESCRIPTION	QTY	REV
1	5535119	M5 X 30MM FLOOR ANCHOR	4	---
2	5530312	RHPS M5 X 55MM	4	---
3	5530310	FIG IEE-04JIC-04JIC-04JIC	2	---
4	5545005	M6 FLAT WASHER	8	---
5	5535112	NUT M6 X 1.0	8	---
6	5540116	TRUARC Ø12mm 5103-50	8	---
7	5545201	WASHER M12 SPRING LOCK	4	---
8	5530152	HHB M12 X 1.5 X 30mm	4	---
9	5530047	HHB M6 X 1 X 30mm	4	---
10	5540006	SNAP RING TRUARC-5103-100	4	---
11	5530167	HHB M10 X 1.5 X 45mm	4	---
12	5545200	WASHER M10 X Ø18 SL	4	---
13	5535998	NUT M10 X 1.5	4	---
14	5545535	C WASHER SHIM FOR LIFTS	20	---
15	5550489	FIG IEE 1/4-1/4-1/4 TUBE INS	3	---
16	5590175	POWER UNIT CONSOLE PUSH BUTTON AIR VALVE	1	---
17	5550486	FIG NPT .02 NPT X .04 NPT	1	---
18	5550410	FIG ELB 1/4 TUBE INS 1/8 NPT	1	---
19	5550183	FIG ELB-06 JIC-06L ORB	1	---
20	5530019	HHB M6 X 1 X 16	4	---
21	5550106	FIG ELB-04 JIC-06 NPT	1	---
22	5550147	FIG NPL-04 JIC X-04 NPT	2	---
23	5550086	FIG ELB-04 NPT X-04 JIC	2	---

DO NOT SCALE DRAWING
DIMENSIONS ARE IN MM

NAME DATE
TM 01/15/2013
MM 02/20/2013



THIRD ANGLE PROJECTION

TITLE:
XR-12000 SERIES PARTS BAG

SIZE DWG. NO. A 5174680

REV A

MATERIAL: ---
SIZE: ---

NOTE: UNLESS OTHERWISE SPECIFIED.
1. SEE SHIPPING INSTRUCTIONS FOR FINAL PACKAGING

NEXT ASSEMBLY
5250098

SCALE: 1:20

SHEET 1 OF 1

BendPak 1645 LEMONWOOD DR.
SANTA PAULA, CA 93060

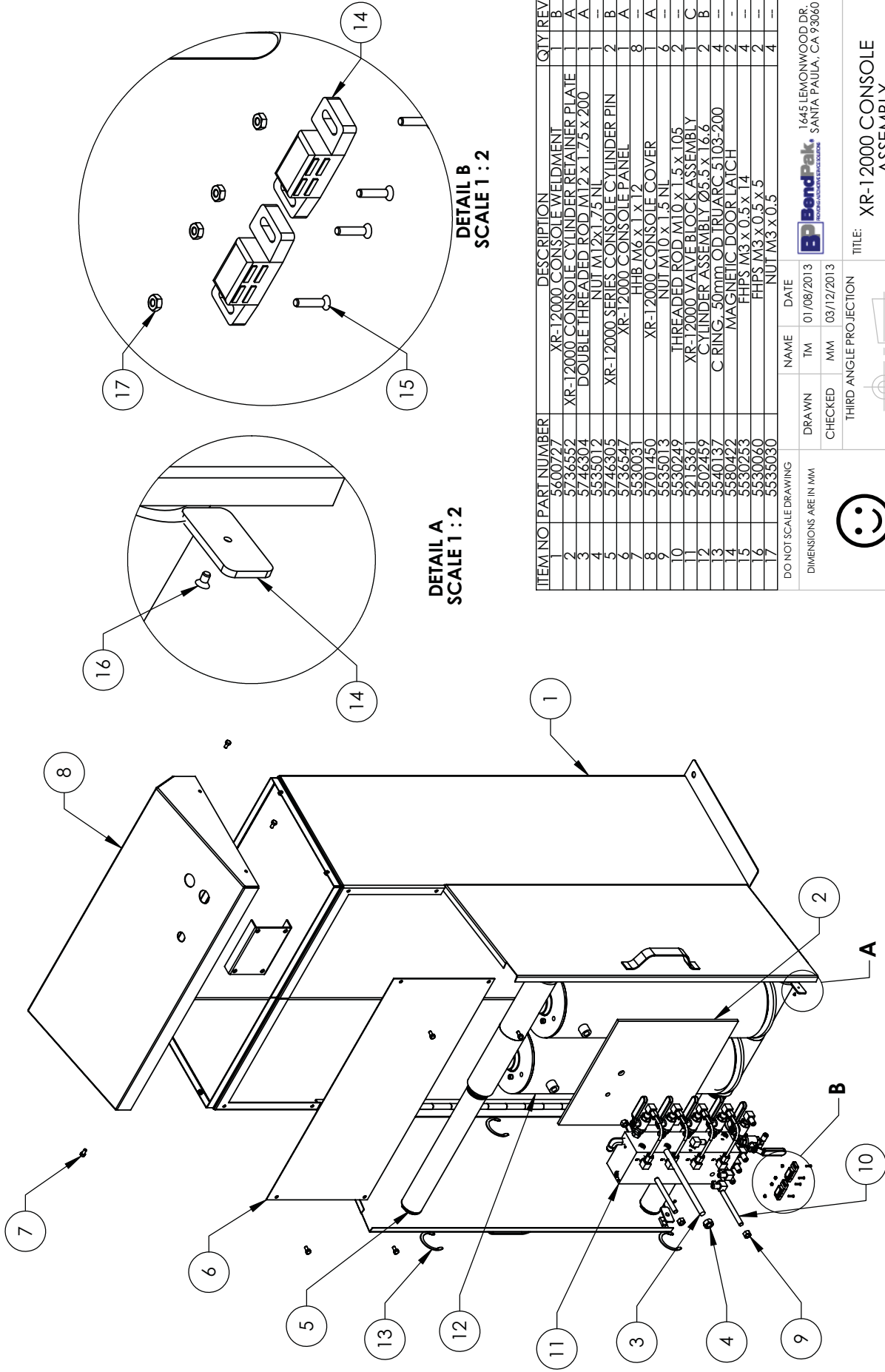

DETAIL A
SCALE 1 : 2

DETAIL B
SCALE 1 : 2

ITEM NO	PART NUMBER	DESCRIPTION	QTY	REV
1	5600727	XR-12000 CONSOLE WELDMENT	1	B
2	5736552	XR-12000 CONSOLE CYLINDER RETAINER PLATE	1	A
3	5746304	DOUBLE THREADED ROD M12 x 1.75 x 200	1	A
4	5535012	NUT M12 x 1.75 NL	1	A
5	5746305	XR-12000 SERIES CONSOLE CYLINDER PIN	2	B
6	5736547	XR-12000 CONSOLE PANEL	1	A
7	5530031	HHB M6 x 1 x 12	8	A
8	5701450	XR-12000 CONSOLE COVER	1	A
9	5535013	NUT M10 x 1.5 NL	6	A
10	5530249	THREADED ROD M10 x 1.5 x 105	2	A
11	5215361	XR-12000 VALVE BLOCK ASSEMBLY	1	C
12	5502459	CYLINDER ASSEMBLY 05.5 x 16.6	2	B
13	5540137	C RING 50MM OD TRUARC 5103-200	4	A
14	5580472	MAGNETIC DOOR LATCH	2	A
15	5530253	FHPS M3 x 0.5 x 14	4	A
16	5530060	FHPS M3 x 0.5 x 5	2	A
17	5535030	NUT M3 x 0.5	4	A

DO NOT SCALE DRAWING

NAME: TM DATE: 01/08/2013

DRAWN: MM CHECKED: MM 03/12/2013

TITLE: XR-12000 CONSOLE ASSEMBLY

SIZE DWG. NO.: A 52155779 REV: D

SCALE: 1:12 SHEET 1 OF 1

THIRD ANGLE PROJECTION

PROPRIETARY AND CONFIDENTIAL
THE INFORMATION CONTAINED IN THIS DRAWING IS THE PROPERTY OF BENDPAK INC. ANY REPRODUCTION IN PART OR AS A WHOLE WITHOUT THE WRITTEN PERMISSION OF BENDPAK INC. IS PROHIBITED.

MATERIAL: ---

SIZE: ---

1645 LEMONWOOD DR.
SANTA PAULA, CA 93060

BendPak
INDUSTRIAL EQUIPMENT DIVISION

NOTE: UNLESS OTHERWISE SPECIFIED.
SEE SHIPPING INSTRUCTIONS FOR FINAL PACKAGING

NEXT ASSEMBLY
ITEM ACCESSORIES

This page intentionally left blank.

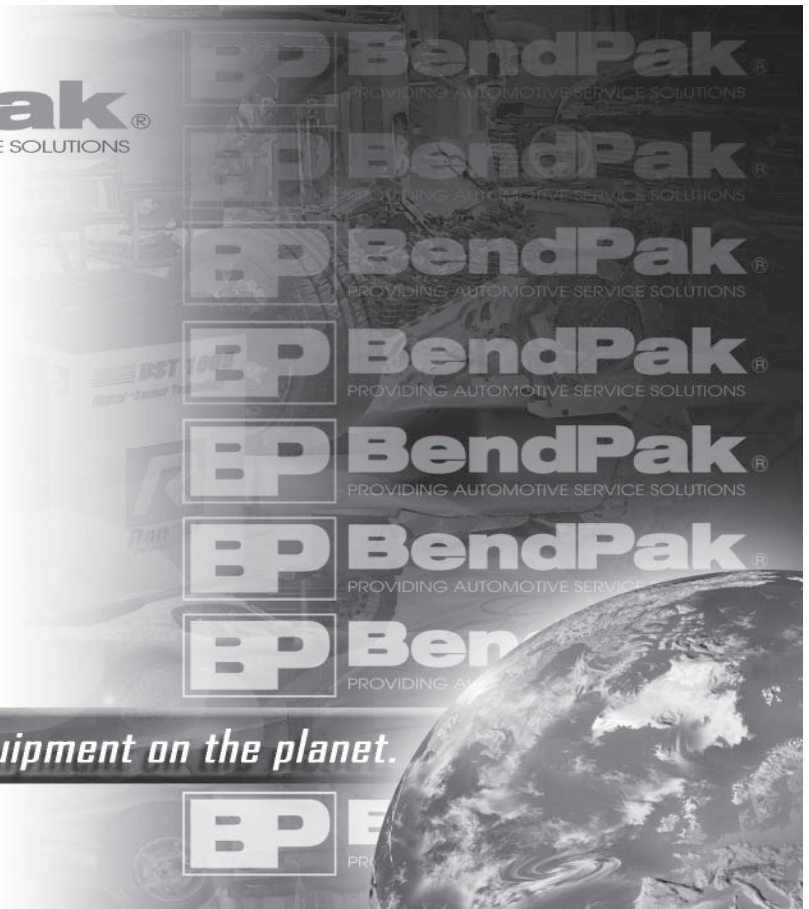

The best automotive service equipment on the planet.

**For Parts Or Service
Contact:**

**BendPak Inc. / Ranger Products
1645 Lemonwood Dr.
Santa Paula, CA. 93060**

**Tel: 1-805-933-9970
Toll Free: 1-800-253-2363
Fax: 1-805-933-9160**

www.bendpak.com

p/n 5900050

